

D	Änderungen bezüglich Konstruktion, Ausrüstung, Farbe sowie Irrtum vorbehalten. Angaben und Abbildungen unverbindlich.	D	Einbauanleitung
GB	Subject to change in terms of construction, equipment and colour, and may contain errors. The information and illustrations are non-binding.	GB	Installation instructions
F	Sous réserve de modifications de la construction, de l'équipement, de la couleur et sous réserve d'erreurs. Les indications et les illustrations sont sans engagement.	F	Consignes de montage
NL	Wijzigingen met betrekking tot constructie, uitrustering en kleur evenals vergissingen voorbehouden. Gegevens en afbeeldingen niet bindend.	NL	Montagehandleiding
DK	Ændringer med hensyn til konstruktion, udstyr, farver samt fejl forbeholdes. Oplysninger og illustrationer er uforpligtende.	DK	Montagevejledning
N	Ændringer angående konstruktion, utstyr, farge og feiltagelse forbeholdes. Opplysninger og illustrasjoner uforbindelig.	N	Monteringsinstruksjon
S	Med reservation för ändringar vad det gäller konstruktion, utrustning, färg samt för misstag. Uppgifterna och bilderna är inte bindande.	S	Installationsanvisning
FIN	Pidätämme oikeuden rakennetta, varustusta, väriä koskeviin sekä erehdykseenä johtuviin muutoksiin. Tiedot ja kuvat eivät ole sitovia.	FIN	Asennusohje
I	Con riserva di modifiche relative a progettazione, dotazione, colore ed errori. Le indicazioni e figure sono fornite senza impegno.	I	Istruzioni per il montaggio
E	Reservadas las modificaciones respecto a diseño, equipamiento, color, así como error. Indicaciones y figuras sin compromiso.	E	Instrucciones de montaje
P	Reservamos o direito de alterações relativamente ao desenho, equipamento, cor, bem como de erro. Os dados e as gravuras não implicam compromisso da nossa parte.	P	Instruções de montagem
GR	Διατηνούμε κάθε επιρρύση ως προς αλλαγές σε σχέση με κατασκευή, εξοπλισμό, διαρρύθμηση, χρωματισμούς και λάθη παραδρύμης.	GR	Οδηγίες εγκατάστασης
CZ	Změny, týkající se konstrukce, vybavení, barvy, jakož i omyly jsou vyhrazeny. Údaje a vyobrazení jsou nezávazné.	CZ	Návod k montáži
PL	Zastrzega się prawo do zmian dot. konstrukcji, wykończenia, kolorystyki oraz pomylek. Dane i ilustracje niewiązace.	PL	Instrukcja montażu
TR	Tasarım, donanım ve renk bakımından deęiliskilik yapma hakkı ve hata ve eksiklik mahfuzdur. Veriler ve resimler baęlayıcı deęildir.	TR	Montaj talimatı
H	A szerkezet, a kivitel és a szín változtatása, valamint a változások joga fenntartva. Az adatok és az ábrák nem kötelező érvényőak.	H	Beépítési útmutató
HR	Pravo promjena u svezi konstrukcije, opreme, boje kao i zabune otdržavamo. Podaci i ilustracije su neobavezne.	HR	Upute o ugradnji
BUL	Запазени права по отношение на конструкцията, оборудването, цвета и грешки. Данните и изображенията не са обвързани.	BUL	Инструкция за монтаж
RO	Ne rezervăm dreptul unor modificări ale construcției, dotării, culorii și dreptul la erori. Datele indicate și imaginile sunt orientative.	RO	Instrucțiuni de montaj
RUS	Права на внесение изменений относительно конструкции, оснащения, окраски, а также на ошибки сохраняются. Данные и иллюстрации имеют примерный характер.	RUS	Инструкция по монтажу и установке
LT	Pasiliekama konstrukcijos, įrangos bei rėikmenų spalvos pakaitimų ir klaidų teisė. Duomenys ir iliustracijos neįpareigojantys.	LT	Montavimo informacija
LV	Tiek paturētas tiesības uz konstrukcijas, iekārtu, krāsas izmaiņām, kā arī kļūdītānos. Dati un attēli bez saistībām.	LV	Iemontēšanas pamācība
EST	Konstruktsioonid, varustuse ja vevryl osas muudatused ning eksimline lubatud. Andmed ja joonised on mitteesiduvad.	EST	Paigaldusjuhend
SLO	Zadržana pravica do sprememb glede konstrukcije, opreme, barve ter pomote. Podatki in slike so neobvezne.	SLO	Navodilo za vgradnjo
SK	Zmeny, ktoré sa týkajú konštrukcie, vybavenia, farby, ako aj omyly sú vyhradené. Údaje a zobrazenia sú nezáväznė.	SK	Montážny návod

GM Europe GmbH

Bahnhofsplatz 1, D-65423 Rüsselsheim, Germany

Water Heater Unit



Thermo Top C Additional Heater e1 00 0002

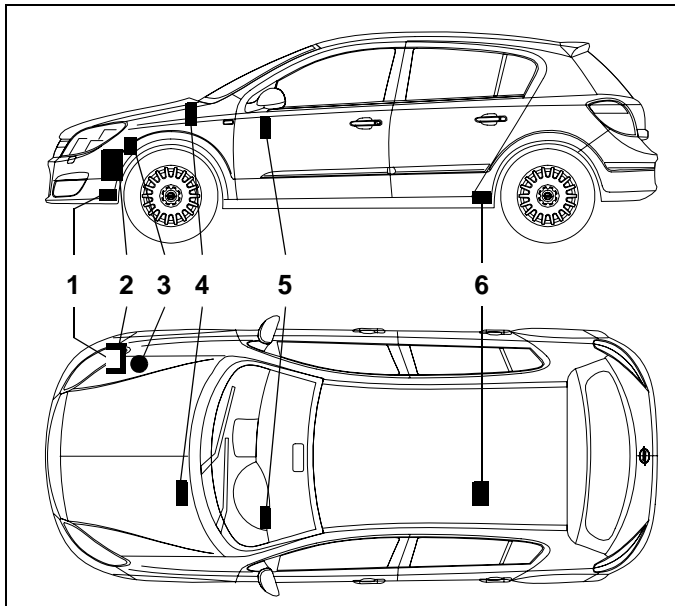

Installation Instructions

Opel Astra
Opel Astra Caravan
Opel Astra GTC
Opel Astra Twin Top

Gasoline and Diesel

from Model Year 2004

For left-hand drive vehicles only

Legend for Figure 1:

- 1 Exhaust muffler
- 2 Thermo Top C/E heater unit
- 3 Combustion-air intake muffler
- 4 Blade-type fuse holder
- 5 Digital timer
- 6 Metering pump



WARNING!
Hazard warning:

Incorrect installation or repair of Webasto heating systems may cause a fire or result in the emission of carbon monoxide, which can be fatal. Serious or fatal injuries can be caused as a result.

Specialist company training, technical documentation, specialized tools and equipment are required to install and repair Webasto heating and cooling systems.

NEVER attempt to install or repair Webasto heating or cooling systems if you have not successfully completed the company training and thereby acquired the required technical skills, or if you do not have access to the required technical documentation, tools and equipment needed to carry out correct installation and repairs.

ALWAYS follow all Webasto installation and repair instructions and observe all warnings.

Webasto does not accept any liability for defects and damage that are attributable to installation by untrained staff.

Table of Contents

Table of Contents	2
Validity	3
Foreword	4
General Instructions	4
Heater Unit/Installation Kit	4
Special Tools	4
Explanatory Notes on Document	5
Preliminary Work	6
Heater unit installation location	6
Preparing wiring harness	7
Vehicles with automatic air-conditioning (ECC and SAC)	7
Vehicles with passenger compartment monitoring	7
Electrical Connections	8
Fan controller	9
Vehicles with passenger compartment monitoring	7
Manual air conditioning without passenger compartment monitoring	10
Manual air conditioning with passenger compartment monitoring	11
Automatic air-conditioning without passenger compartment monitoring (ECC and SAC)	12
Automatic air-conditioning with passenger compartment monitoring (ECC and SAC)	13
Remote option (Telestart)	14
Remote option (Thermo Call)	15
Combustion air	16
Preparing installation location	17
Preparing heater unit	19
Installing heater unit	19
Fuel Connection	21
Metering pump	21
Removing fuel	22
Diagram for coolant of 1.4 liter; 2.0 liter gasoline	25
Diagram for coolant of 1.6 liter Z16XEP; 1.8 liter gasoline and 1.3 liter; 1.7 liter diesel	26
Diagram for coolant of 1.6 liter Z16XER	27
Diagram for coolant of 1.6 liter Z16LET	28
Diagram for coolant of 1.9 liter diesel	29
Cutting coolant hoses to length	30
1.6 liter gasoline Z16XEP	30
1.6 liter gasoline Z16XER	30
1.6 liter gasoline Z16LET	31
1.8 liter gasoline	31
2.0 liter gasoline	33
1.3 liter and 1.7 liter diesel	32
1.9 liter Diesel	32
Preparing coolant hoses	32
All vehicles	33
All vehicle except 2.0 liter gasoline	33
2.0 liter gasoline	33
Coolant connection	34
1.6 liter gasoline Z16XEP	30
1.6 liter gasoline Z16XER	30
1.6 liter gasoline Z16LET	31
1.8 liter gasoline	31
2.0 liter gasoline	33
1.3 liter diesel	41
1.7 liter diesel	42
1.9 liter Diesel	32
Exhaust system	46
Gasoline	47
Diesel	47
All vehicles	33
Final Work	49
Operating Instructions for End Customer	50
Template for Fuel Sender	51
Template for Fuel Standpipe	52

Validity

Manufacturer	Model	Type	EG-BE No./ABE
Opel	Astra H	A-H	e1*2001/116*0261
Opel	Astra H	A-H	e1*2001/116*0293
Opel	Astra H Twin Top	A-H/C	e4*2001/116*0094

Engine type	Engine model	Output in kW	Displacement in cm ³
Z14XEL	Gasoline	55	1364
Z14XEP	Gasoline	66	1364
Z16XEP	Gasoline	77	1598
Z16XER	Gasoline	85	1598
Z16LET	Gasoline	132	1598
Z18XER	Gasoline	103	1796
Z18XE	Gasoline	92	1796
Z20LEH	Gasoline (OPC)	177	1998
Z20LEL	Gasoline	125	1998
Z20LER	Gasoline	147	1998
Z13DTH	Diesel	66	1248
Z17DTL	Diesel	59	1686
Z17DTH	Diesel	74	1686
Z17DTJ	Diesel	81	1686
A17DTJ	Diesel	81	1686
Z17DTR	Diesel	92	1686
A17DTR	Diesel	92	1686
Z19DTL	Diesel	74	1910
Z19DT	Diesel	88	1910
Z19DTH	Diesel	110	1910

Vehicle models, engine types, equipment variants as well as national specifications, which are not listed in these installation instructions, have not been tested.

However, installation according to these installation instructions may be possible.

The installation location of a digital timer and summer/winter switch should be confirmed with the end customer before installation.

Heater Unit/Installation Kit

Quantity	Designation	Order No.
1	<i>Thermo Top C-B</i> Water Heater Unit <i>with delivery scope</i>	83343C
	Opel Catalog No.:	1734010
	or	
1	<i>Thermo Top C-D</i> Water Heater Unit <i>with delivery scope</i>	83344C
	Opel Catalog No.:	1734011

Also required:

1	Heater control	see Opel Price List
---	----------------	---------------------

Also required:

1	Installation Kit for Opel Astra	1303047F
	Opel Catalog No.:	1734115

Only for 1.9 liter diesel vehicles:

1	Bracket for Vacuum Valve: Opel Catalog No.:	1734144
---	---	---------

Foreword

These installation instructions apply to Opel Astra H vehicles - for validity, see page 2 - from model year 2004 and later, assuming technical modifications to the vehicle do not affect installation, any liability claims excluded. Depending on the vehicle version and equipment, modifications may be necessary during installation with respect to these installation instructions.

However, where this is the case the stipulations in the "installation instructions" and "operating and maintenance instructions" for the *Thermo Top C* should be observed.

The corresponding rules of technology and any information from the vehicle manufacturer should be observed during the installation work.

General Instructions

Installation should be carried out according to the general, standard rules of technology. Unless specified otherwise, fasten hoses, lines and wiring harnesses to original vehicle lines and wiring harnesses using cable ties.

Sharp edges should be fitted with edge protectors (split-open plastic hose).

Spray unfinished body areas, e.g. drilled holes, with anti-corrosion wax (Tectyl 100K, Order No. 111329).

Special Tools

- Torque wrench for 2.0 - 10 Nm
- Hose clamping pliers
- Riveting pliers

Explanatory Notes on Document

To provide you with a quick overview of the individual working steps, you will find an identification mark on the outside top right corner of the page in question.

Mechanical work

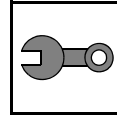

Electrical connection

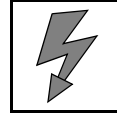

Coolant connection

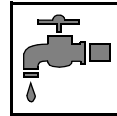

Fuel connection

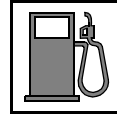

Exhaust system

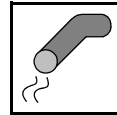

Combustion air

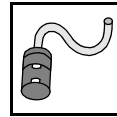

Special features are highlighted using the following symbols:



Specific risk of injury or fatal accidents.



Specific risk of damage to components.



Specific risk of fire or explosion.



Reference to general installation instructions of Webasto components or to the manufacturer's vehicle-specific documents.



Reference to a special technical feature.

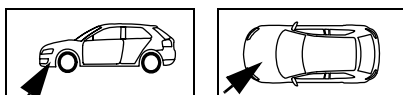

The arrow in the vehicle icon indicates the position on the vehicle and the viewing angle.

Preliminary Work

WARNING!

- Disconnect the battery "earth" or "ground" connection.
- Remove the battery (only on 1.9 liter diesel vehicle).
- Depressurize the cooling system.
- Copy the factory number from the original type label to the duplicate type label.
- Remove years that do not apply from the duplicate label.
- Attach the duplicate label (type label) in the appropriate place.
- Remove the air filter together with the intake hose.
- Open fuel tank cap, ventilate tank.
- Close the tank cap again.
- Remove the front grill.
- Remove the bumper.
- Remove the front section of the wheel well trim on the right.
- Remove the horns.
- Remove the vacuum valve (only on 1.9 liter diesel vehicle).
- Remove the underride protection (depending on vehicle equipment).
- Remove the rear bench seat.
- Remove the service cover of the fuel-tank sending unit.
- Remove the lower instrument panel trim on the driver's side.
- Remove the glove compartment (only on vehicles with manual air-conditioning).
- Remove the A/C control panel (only on vehicles with automatic air-conditioning).
- Remove the A-pillar trim in the footwell on the front passenger side.
- Remove the left-hand door sill cover completely (only on vehicles with alarm system).
- Open the cable duct under the door sill cover (only on vehicles with alarm system).

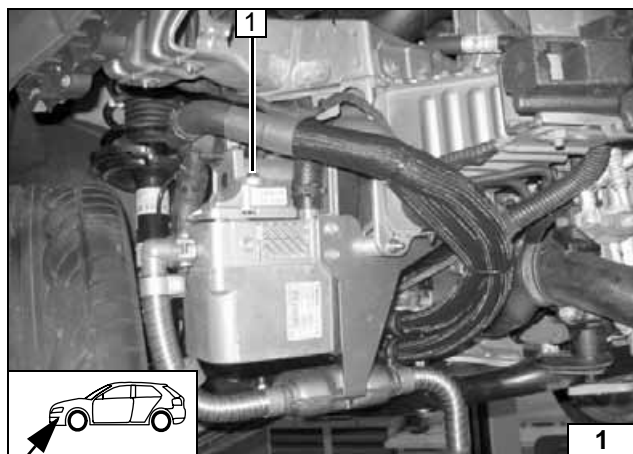

Heater unit installation location

(1) Heater unit

Installation location

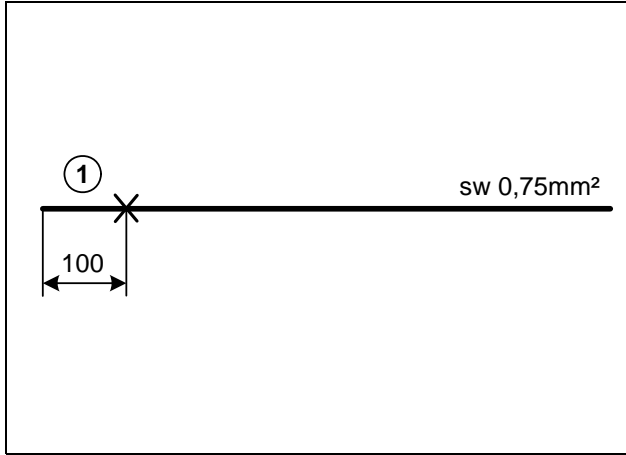

Preparing wiring harness

Vehicles with automatic air-conditioning (ECC and SAC)

Wire section 1 will be required later for connection on A/C control panel.



Cutting wires to length

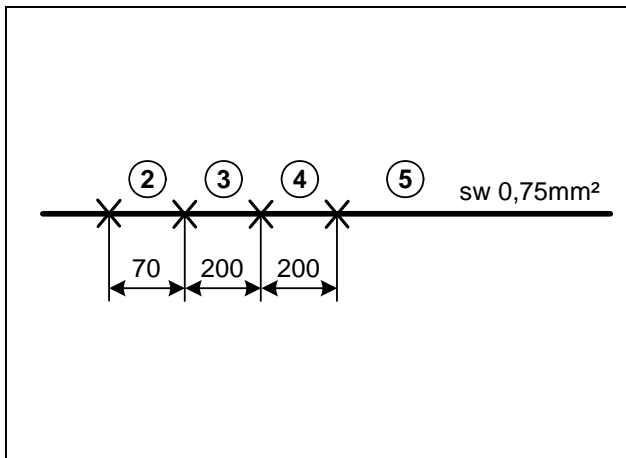

Vehicles with passenger compartment monitoring

Wire sections 2, 3, 4 and 5 will be required later for switching off passenger compartment monitoring.



Cutting wires to length

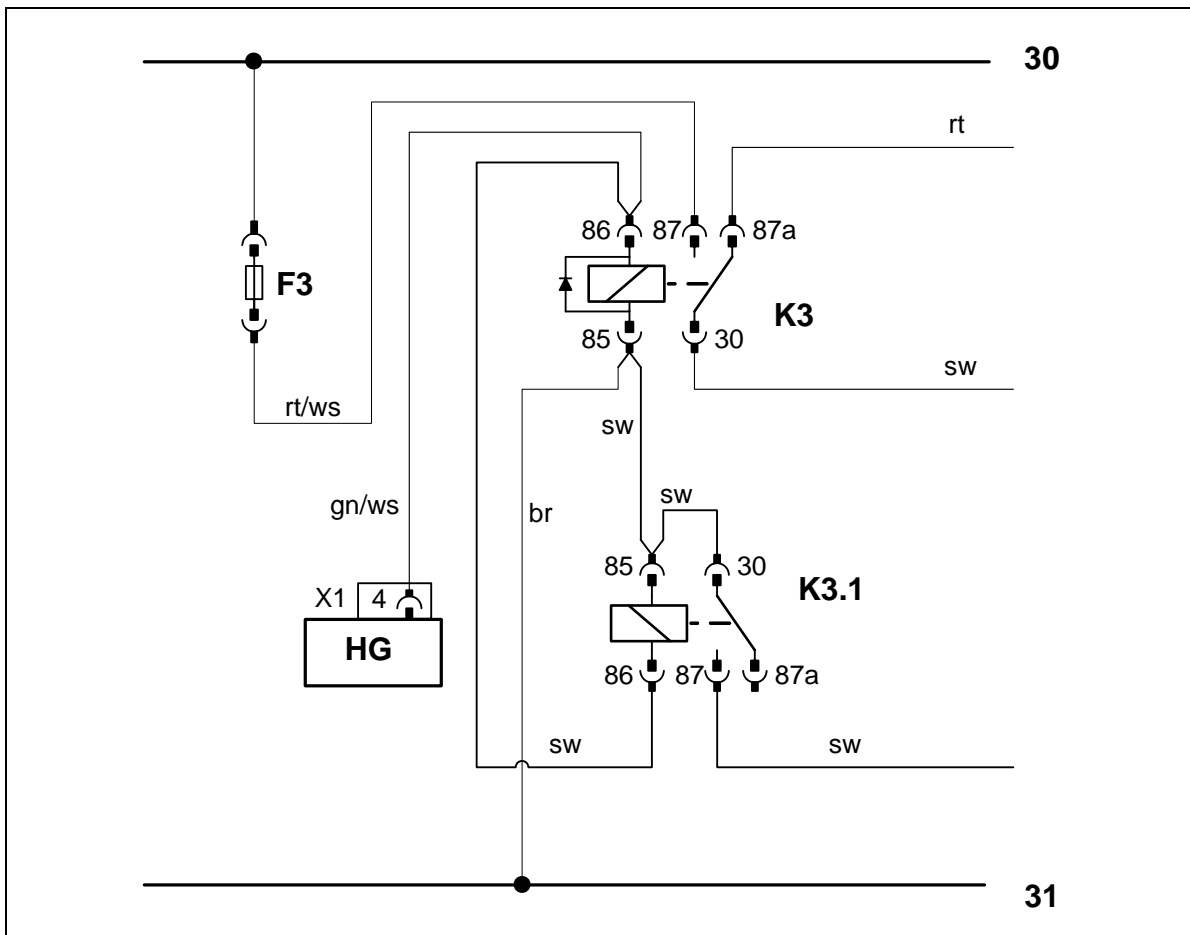

Premounting K3.1 relay with passenger compartment monitoring



Electrical Connections

Wiring harness pass through

Detach bracket of wiring harness (2) from stud bolt (3).

(1) Protective rubber plug

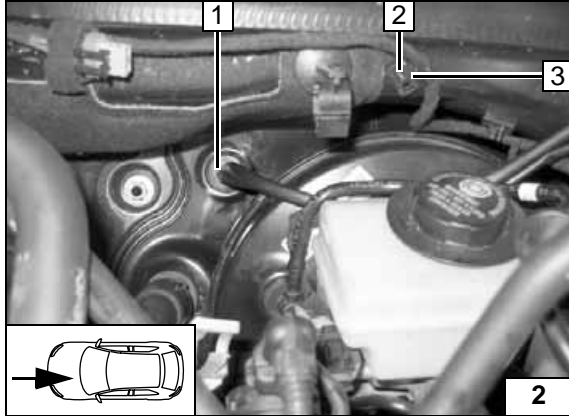

Digital timer, summer/winter switch option

(1) Digital timer, drilling template

(2) Summer/winter switch, hole 12 mm dia.

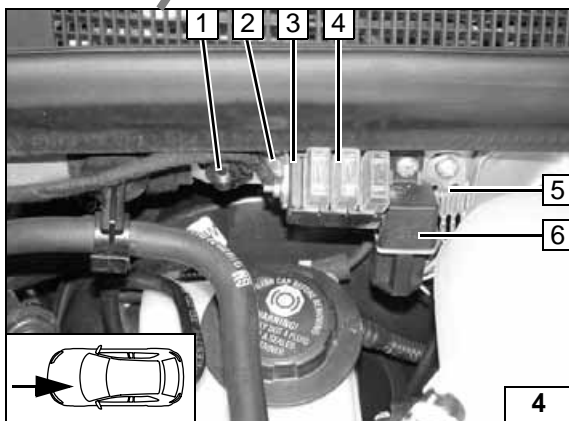
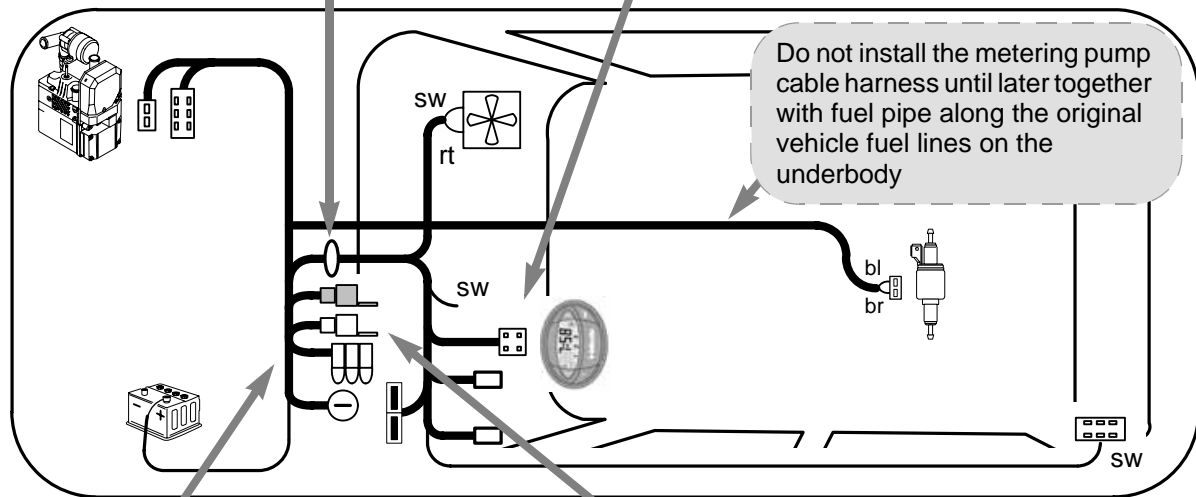
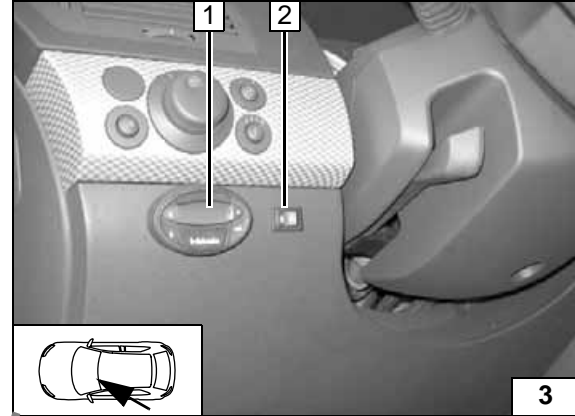

Fuse holder, relay K3

- (1) Original vehicle stud bolt (2/2), bracket of wiring harness (2/3), plastic nut
- (2) Angle bracket
- (3) Retaining plate of fuse holder, M4x10 bolt, washers, M4 nut
- (4) Fuse holder
- (5) Ground support point, 5.5x13 self-tapping screw
- (6) k3 relay, 5.5x13 self-tapping screw

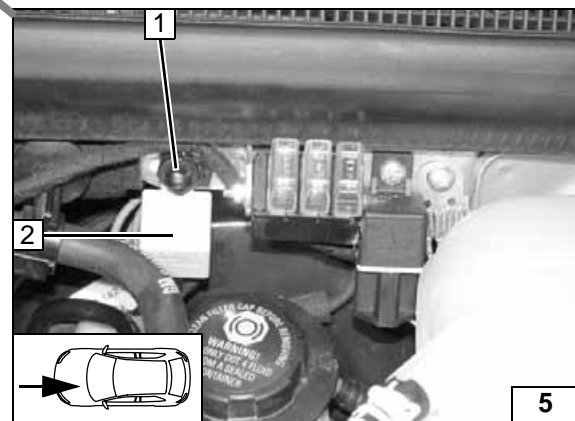

Additional K3.1 relay with passenger compartment monitoring

- (1) Original vehicle stud bolt (2/2), bracket of wiring harness (2/3), K3.1 relay (2), plastic nut
- (2) K3.1 relay



Electrical diagram



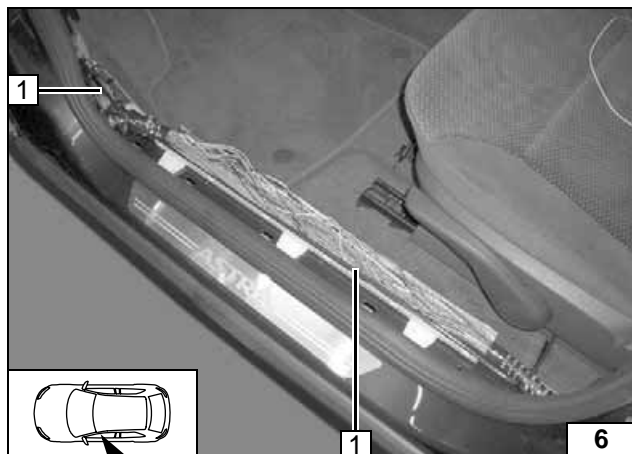

Fan controller

Vehicles with passenger compartment monitoring

Push included protective sleeving onto additional line (wire section 5) up to cable grommet in passenger compartment. Route additional line along left-hand A-pillar in cable duct to rear

(1) Black (sw) 0.75 mm² wire section 5 from K3.1/87

Installing additional line

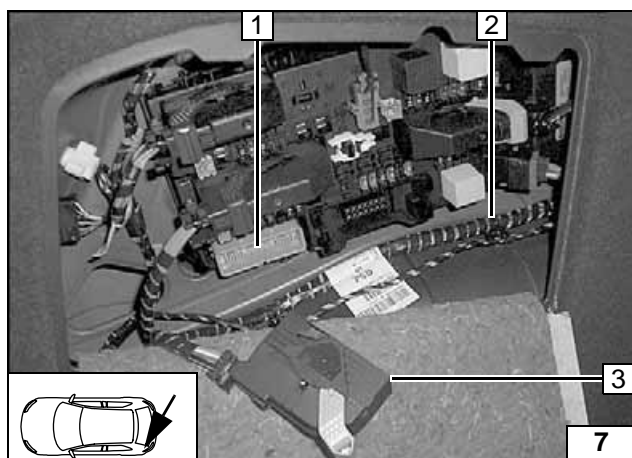

Passenger compartment monitoring is switched off on rear zone module behind left-hand luggage compartment trim!

(2) Wire section 5
(3) Connector X5 disconnected
(1) Socket of connector X5

Disconnecting connector

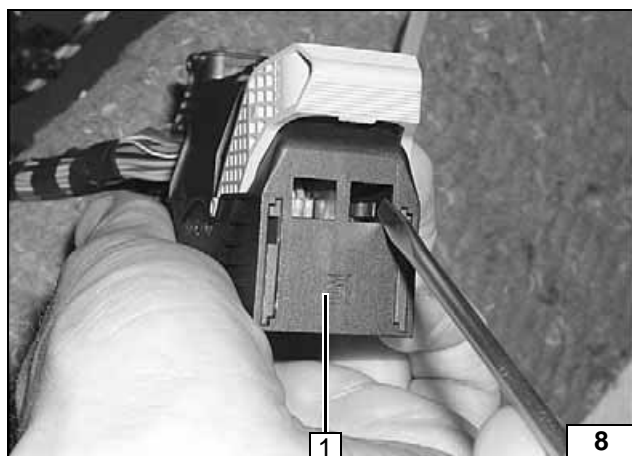

Dismantle connector X5. Cut off front cable tie. Press both unlocking lugs toward rear with small screwdriver and pull off connector housing.

(1) Connector X5

Unlocking connector

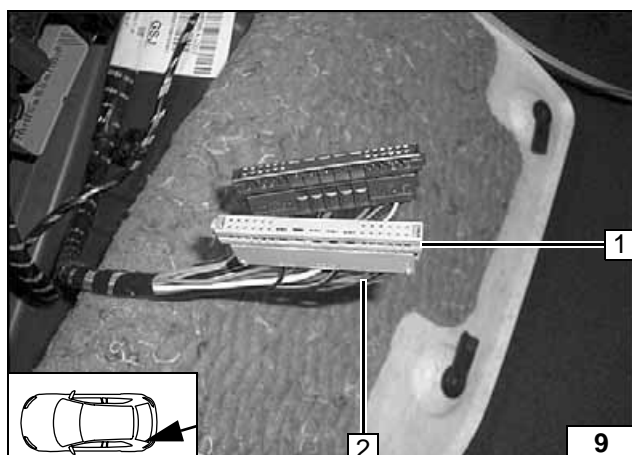

Connection on blue (bl) connector X5 from rear zone module.

Produce connections according to wiring diagram on Page 10 or 12, depending on vehicle equipment.

(1) Connector X5, Pin 12
(2) Wire section 5

Connecting line

Passenger compartment monitoring must be reprogrammed to additional heating mode with TECH 2 tester **according to manufacturer's instructions.**



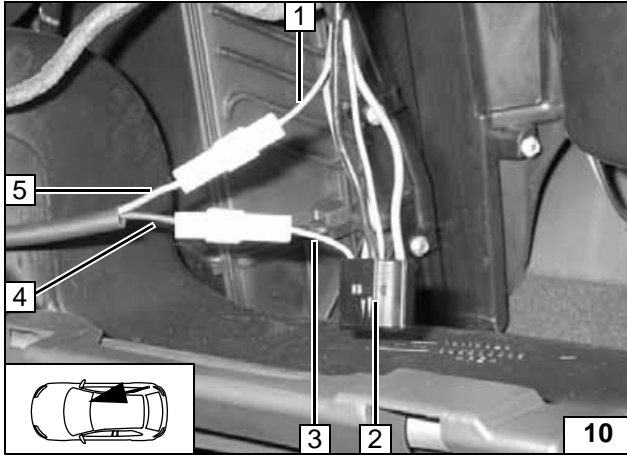

Manual air conditioning without passenger compartment monitoring
 Connection on 5-pin connector of resistor group R1_A60.
 Produce connections as shown in wiring diagram with blade connectors provided.

- (2) 5-pin connector of resistor group
- (1) Violet (vi) wire from fan controls
- (5) Red (rt) wire from K3/87a
- (3) Violet (vi) wire to resistor of speed 2
- (4) Black (sw) wire from K3/30



Fan controller

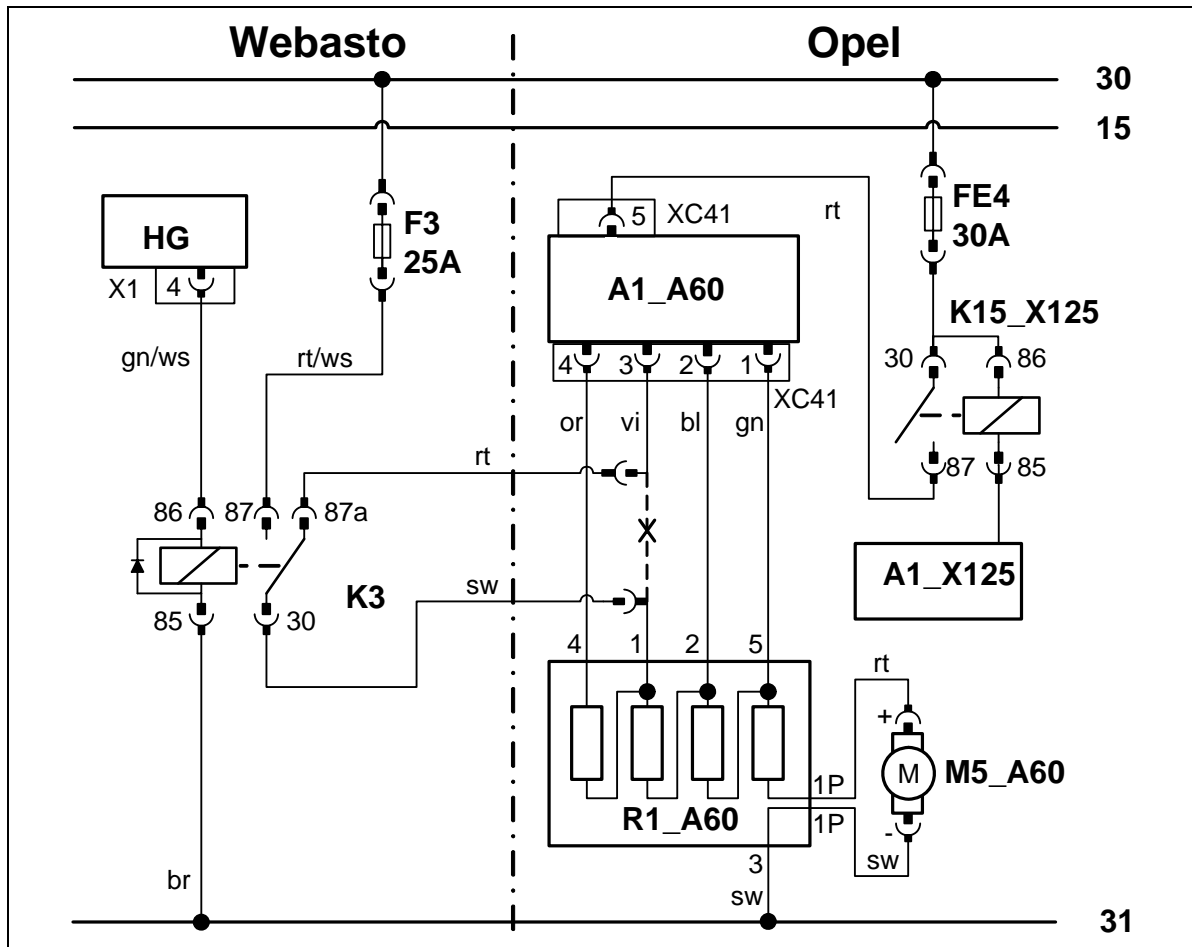

Wiring diagram of manual air conditioning without passenger compartment monitoring

Webasto components		Opel components		Colors and symbols	
HG	Heater unit TT-C/E	FE4	Fan fuse	rt	red
X1	6-pin heater unit connector	K15_X125	Fan relay	ws	white
F3	Fan fuse	A1_A60	Fan controls	sw	black
K3	Fan relay	R1_A60	Resistor group	br	brown
		M5_A60	Fan motor	gn	green
				vi	violet
				or	orange
				bl	blue
				X	Cutting point

Legend



Manual air conditioning with passenger compartment monitoring
 Produce connection in accordance with Figure 10 and Page 9.
 Produce connections as shown in following wiring diagram with blade connectors provided.



Fan controller

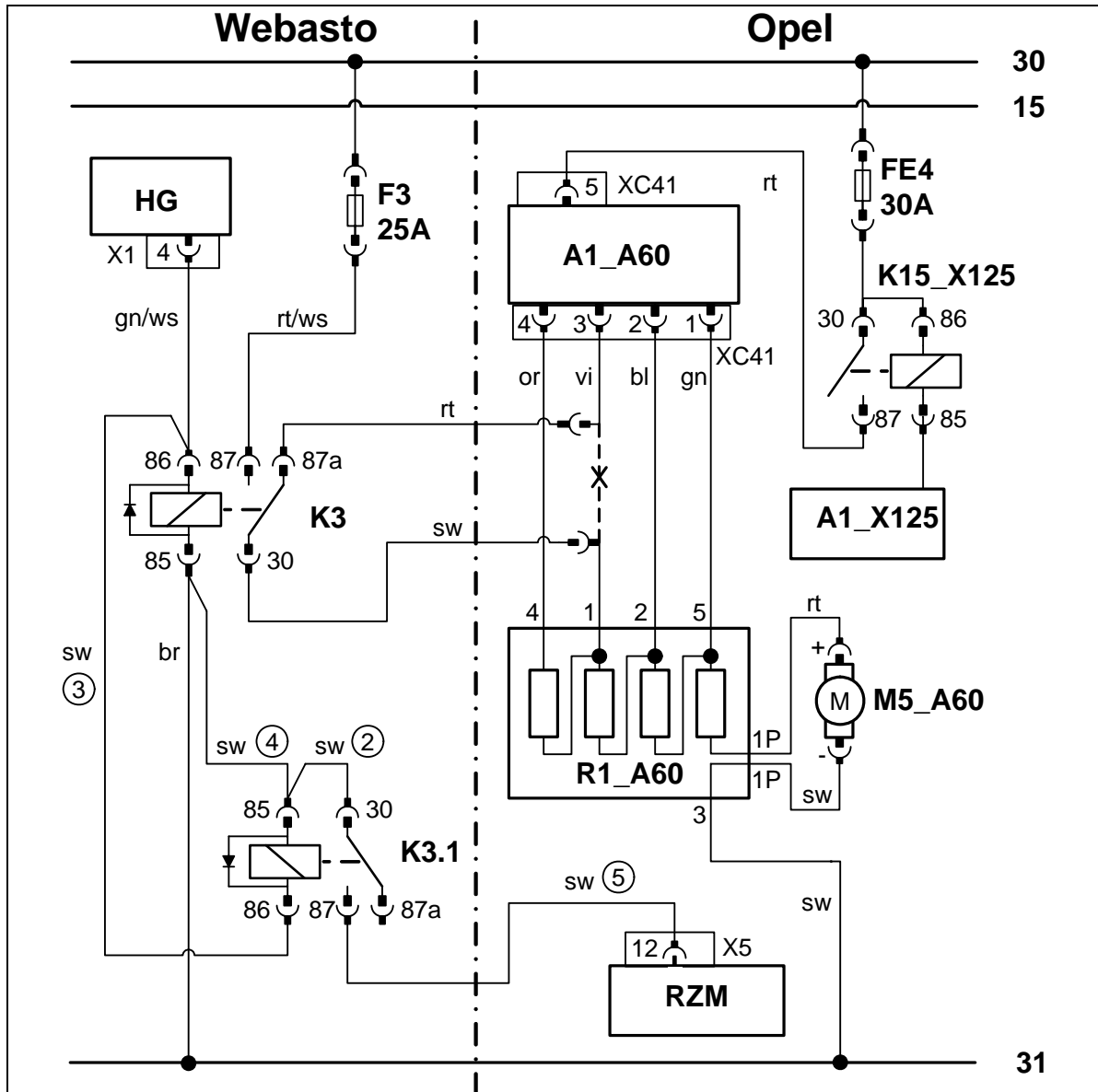

Wiring diagram for manual air conditioning with passenger compartment monitoring

Webasto components		Opel components		Colors and symbols	
HG	Heater unit TT-C/E	FE4	Fan fuse	rt	red
X1	6-pin heater unit connector	K15_X125	Fan relay	ws	white
F3	Fan fuse	A1_A60	Fan controls	sw	black
K3	Fan relay	R1_A60	Resistor group	br	brown
K3.1	Additional relay	M5_A60	Fan motor	gn	green
		RZM	Rear zone module	vi	violet
				or	orange
				bl	blue
				X	Cutting point

Legend

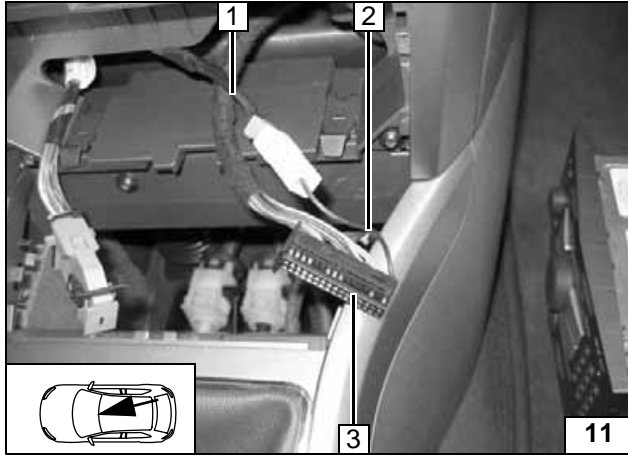

Automatic air-conditioning without passenger compartment monitoring (ECC and SAC)

Connection on gray (gr) 32-pin connector ZF 32 - 1, Pin 1 from A/C control panel.
Produce connections as shown in following wiring diagram with blade connectors provided.
Replace F3 25 A fuse with 1 A fuse.

- (1) Black (sw) wire from K3/30
- (2) Wire section 1
- (3) 32-pin gray (gr) connector ZF 32 - 1



Fan controller

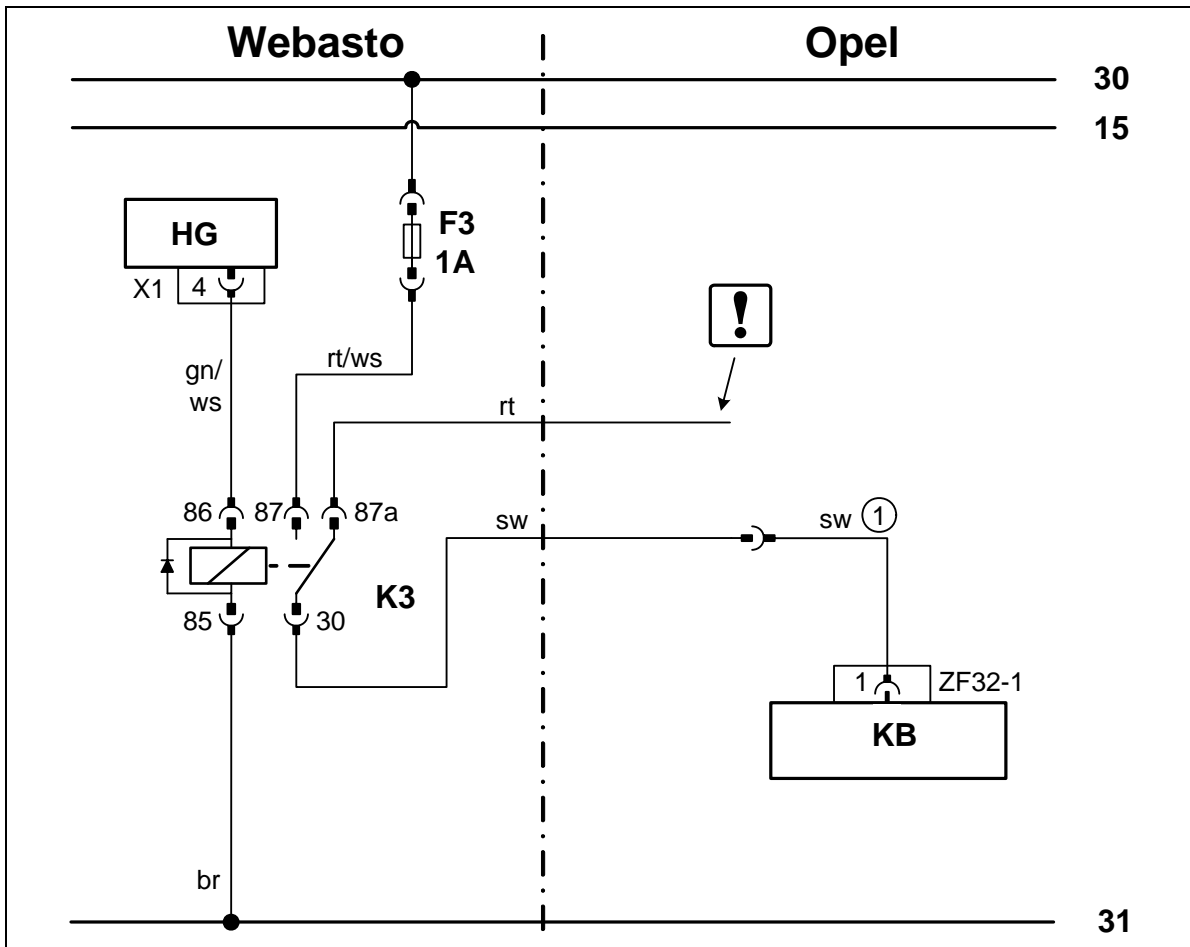

Wiring diagram for automatic air-conditioning without Passenger compartment monitoring (ECC and SAC)

Webasto components		Opel components		Colors and symbols	
HG	Heater unit TT-C/E	KB	Air-conditioning control panel	rt	red
X1	6-pin heater unit connector	ZF 32 - 1	Gray (gr) connector KB	ws	white
F3	Replace 25 A with 1 A fuse.			sw	black
				br	brown
K3	Fan relay			gn	green
					Insulate wire end and tie back

Legend



Automatic air-conditioning with passenger compartment monitoring (ECC and SAC)

Produce connection in accordance with Figure 11 and Page 11.
Produce connections as shown in following wiring diagram with blade connectors provided.



Fan controller

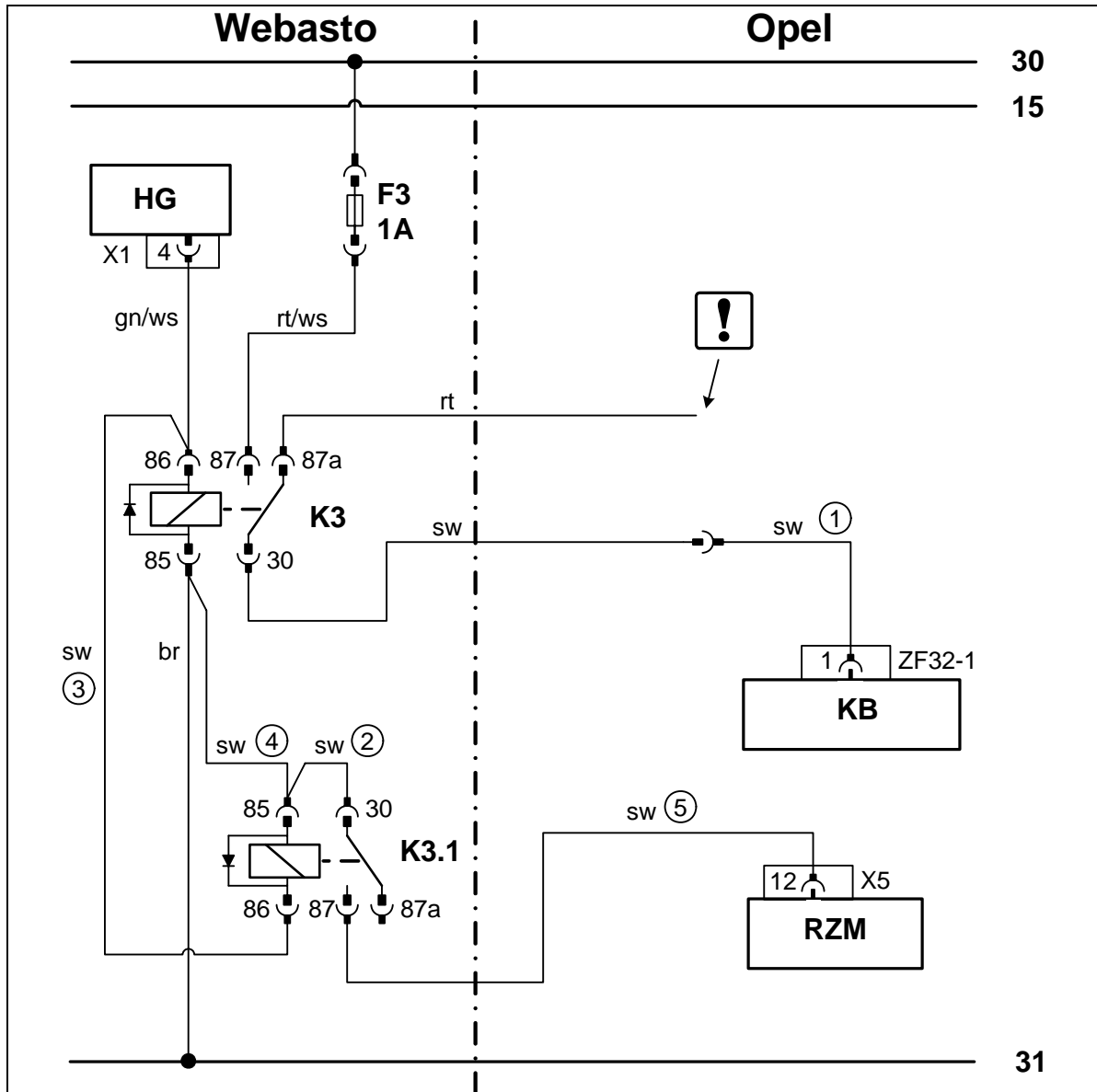

Wiring diagram of automatic air-conditioning with passenger compartment monitoring (ECC and SAC)

Webasto components		Opel components		Colors and symbols	
HG	Heater unit TT-C/E	KB	Air-conditioning control panel	rt	red
X1	6-pin heater unit connector	ZF 32 - 1	Gray (gr) connector KB	ws	white
F3	Replace 25 A with 1 A fuse.	RZM	Rear zone module with connector X5	sw	black
K3	Fan relay			br	brown
K3.1	Additional relay			gn	green
					Insulate wire end and tie back

Legend

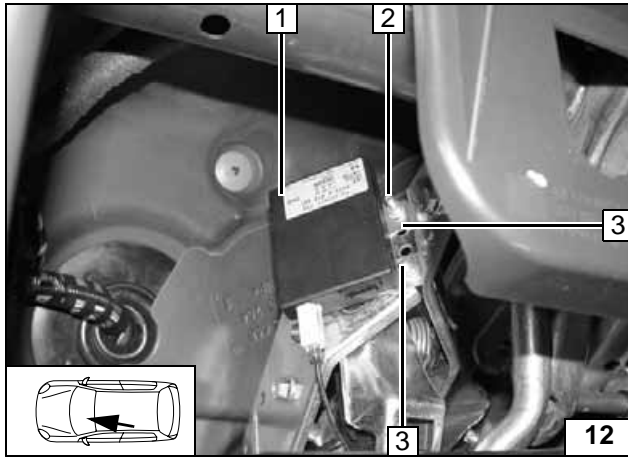

Remote option (Telestart)

- 1 Receiver
- 2 5.5 mm dia.hole, M5x12 bolt, flanged nut [2x]
- 3 Bracket



Installing receiver

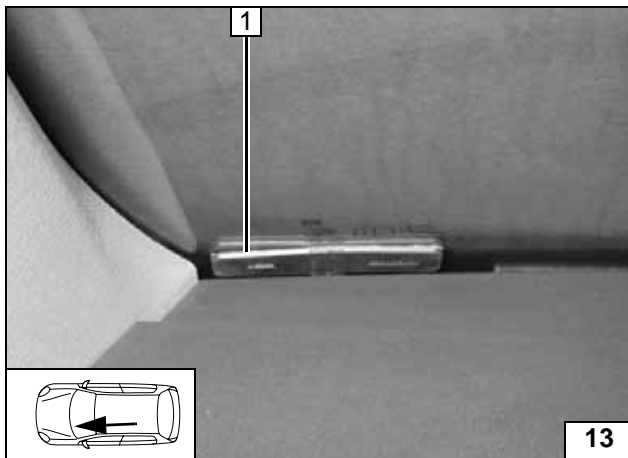

On vehicles without solar reflect windshield!

- 1 Antenna



Installing antenna

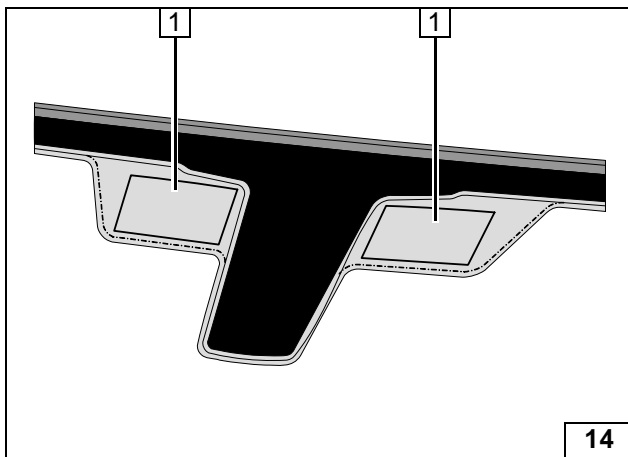

On vehicles with solar reflect windshield (approval stamp on windshield at lower left "C"!

Use provided fields 70 x120 mm 1.



Installing antenna

WARNING!

When installing antenna cable in area of airbags, observe instructions of vehicle manufacturer.



Only with T100HTM

- 1 Temperature sensor T100HTM

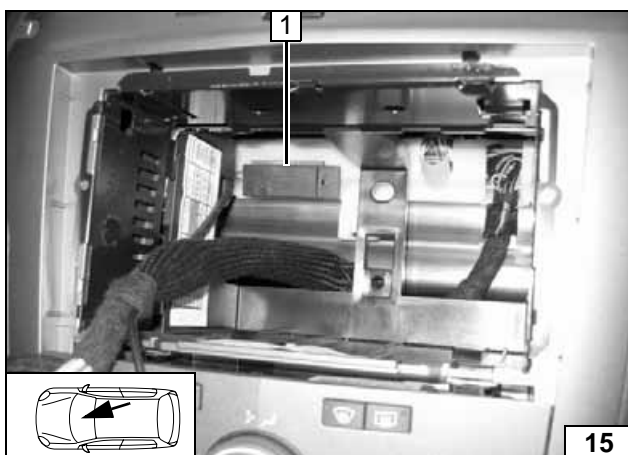

Installing temperature sensor

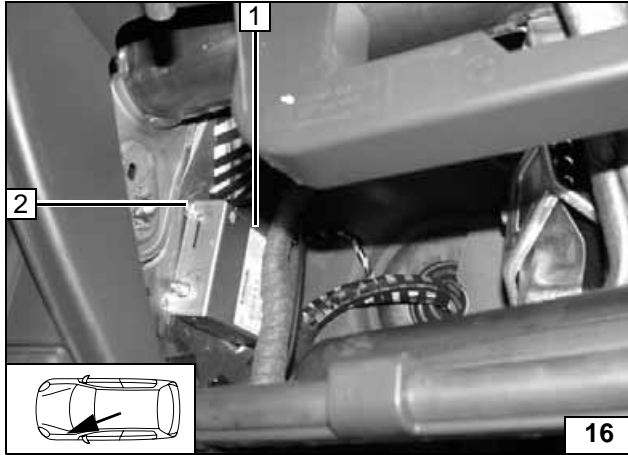

Remote option (Thermo Call)

- 1 Receiver
- 2 4 mm dia. hole, 5.5x9.5 self-tapping screw [4x]



Installing receiver

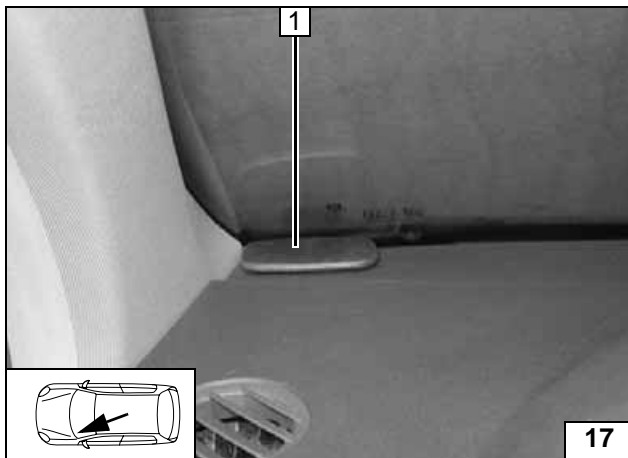

On vehicles without solar reflect windshield!

- 1 Antenna

Installing antenna

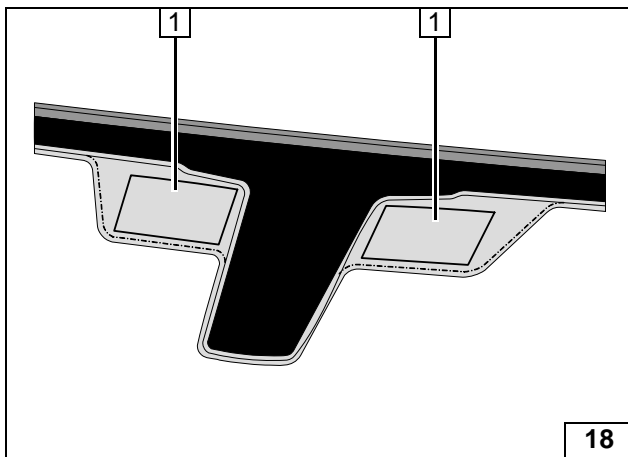

On vehicles with solar reflect windshield (approval stamp on windshield at lower left "C"!

Use provided fields 70 x120 mm 1.



Installing antenna

WARNING!

When installing antenna cable in area of airbags, observe instructions of vehicle manufacturer.

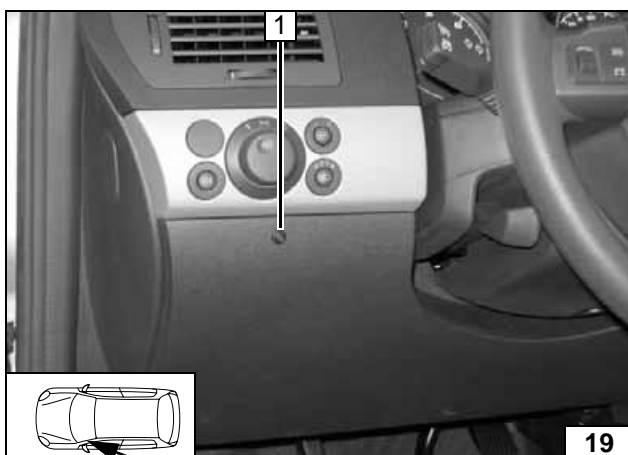

- 1 Pushbutton

Installing push button

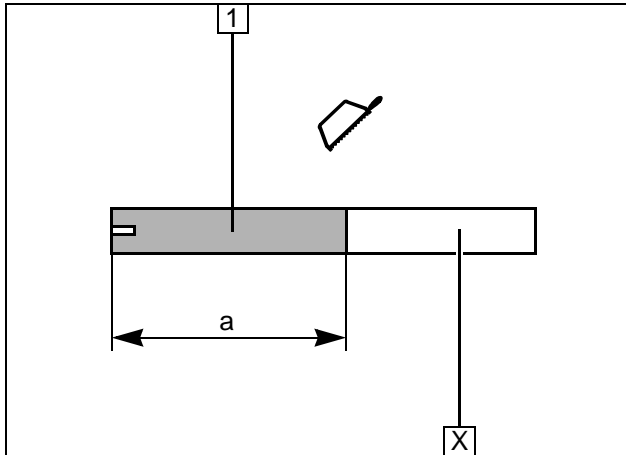
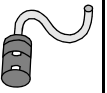

Combustion air

- 1 Combustion air pipe
a = 200 mm

Discard section X

Cutting combustion air pipe to length

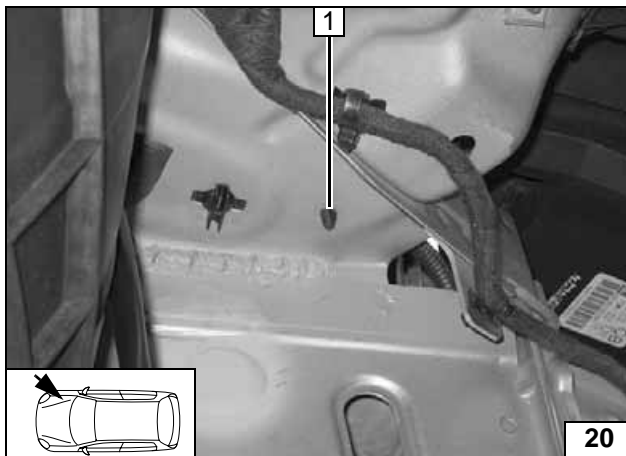

Ensure proper installation position of air intake muffler, see "Installation Instructions".

- 1 Remove retaining clip and fasten wiring harness above wheel well with cable tie



Preassembling intake muffler

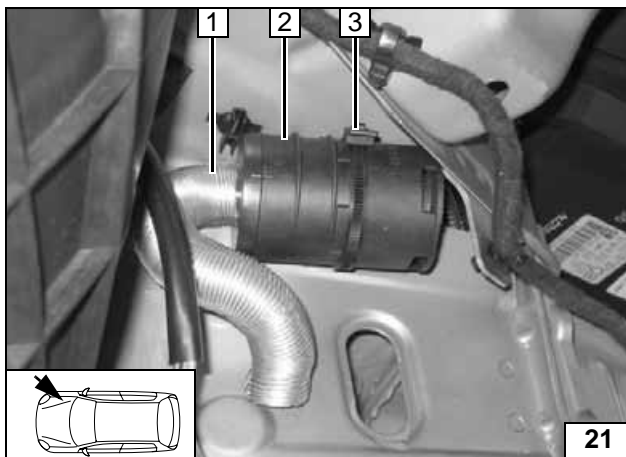

- 1 Combustion-air intake hose shortened
- 2 Intake muffler
- 3 Included clip with cable tie in existing hole

Preassembling intake muffler

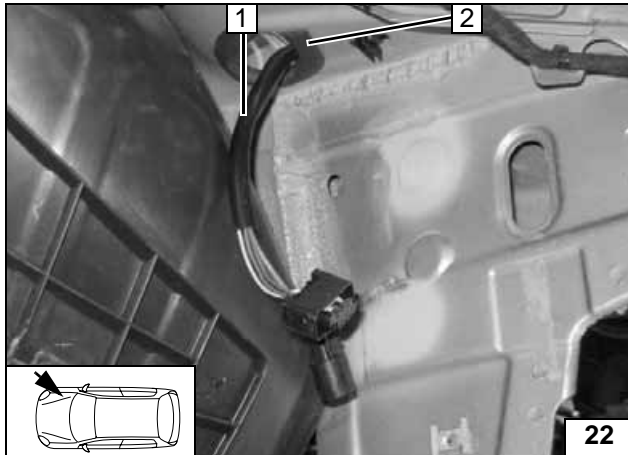
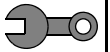

Preparing installation location

Cut included 200 mm long edge protection in center.

- 1 Wiring harness of heater unit
- 2 100 mm long edge protection



Installing edge protection

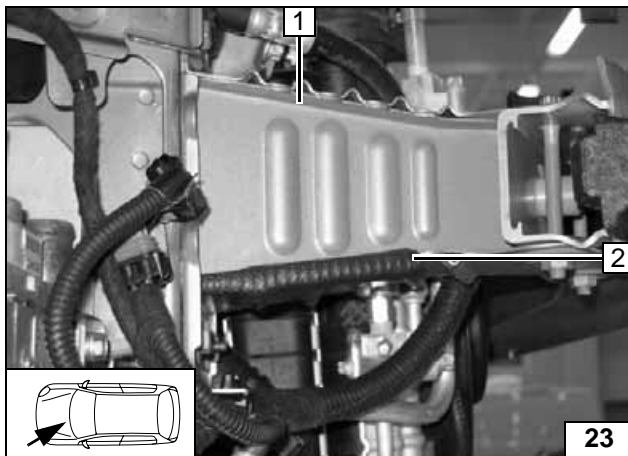

- 1 Cross member of bumper
- 2 100 mm long edge protection

Installing edge protection

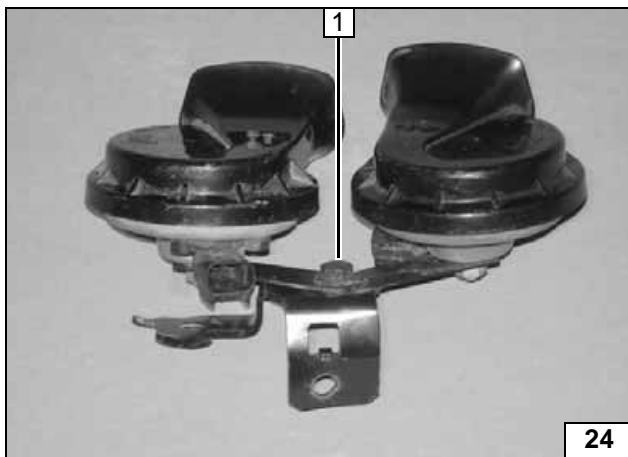

With 2 horns, install brackets as shown (dependent on vehicle equipment).

- (1) Original vehicle bolt



Premounting horns

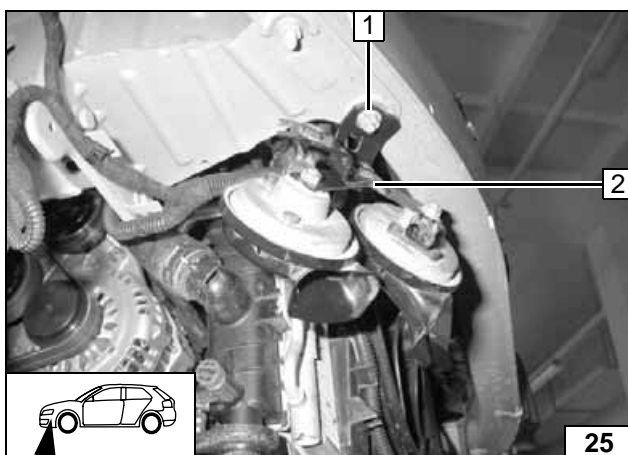

Ensure freedom of movement of neighboring components.

- (1) Original vehicle stud bolt, flanged nut
- (2) Horn bracket



Installing horns

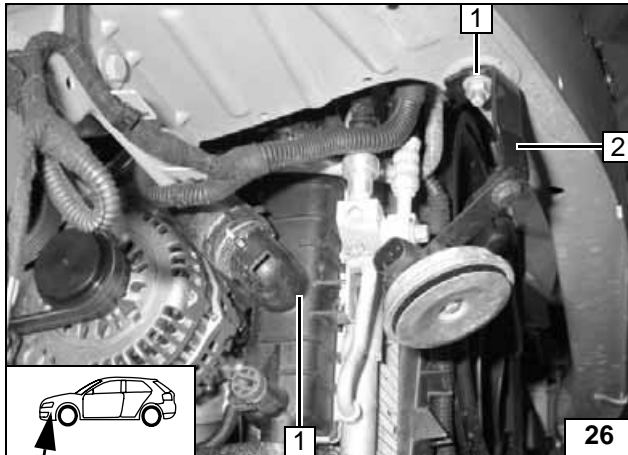
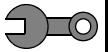

With 1 horn, install brackets as shown (dependent on vehicle equipment). Ensure freedom of movement of neighboring components.

- (1) Original vehicle stud bolt, flanged nut
- (2) Horn bracket



Installing horns

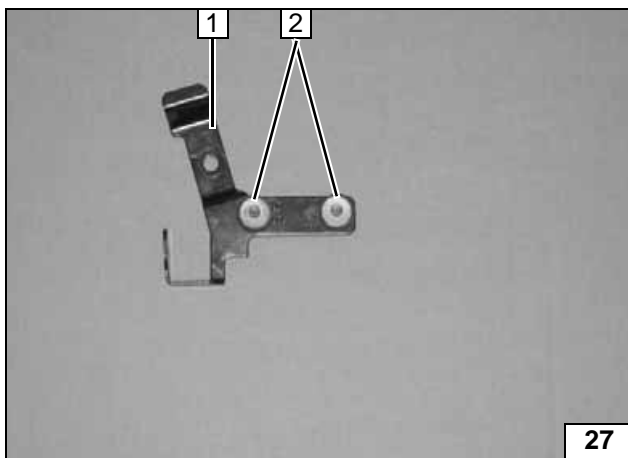

1.9 liter diesel

- 2 Screw out silent block
- 1 Discard original vehicle bracket of vacuum valve



Removing original vehicle bracket

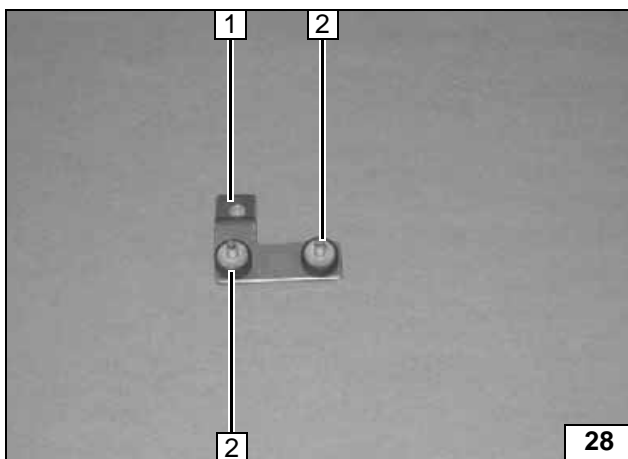

- 1 Bracket of vacuum valve: Opel Catalog No.: 1734144
- 2 Screw in silent block [2x]

Installing included bracket

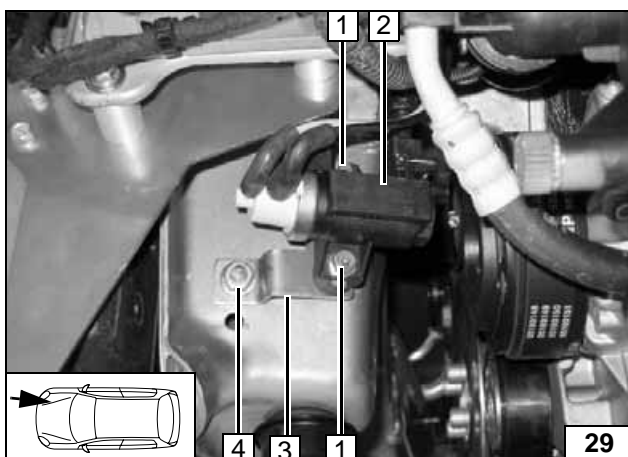

- 3 Bracket of vacuum valve
- 4 Original vehicle stud bolt, flanged nut of horn bracket
- 2 Vacuum valve
- 1 Original vehicle flanged nuts

Installing vacuum valve

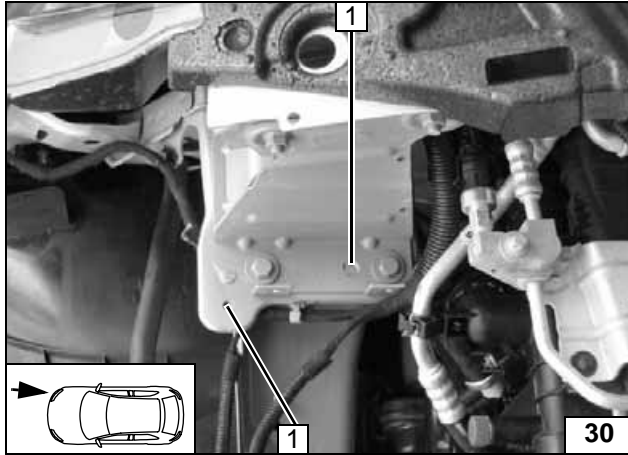
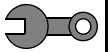
**All vehicles**

Existing holes 1 [2x] will be used for installation of heater unit.

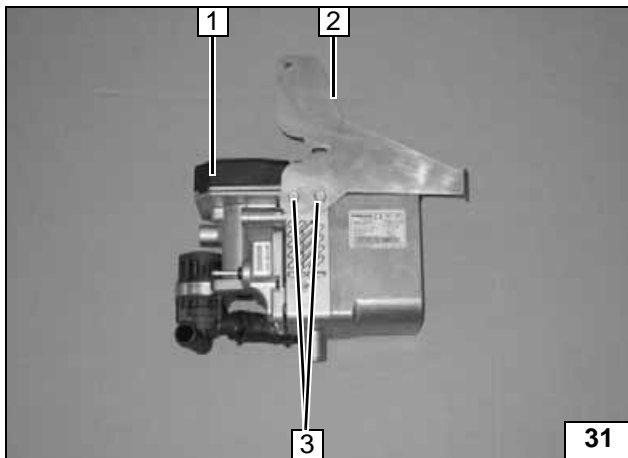
**Installing bracket****Preparing heater unit**

Tighten E-JOT screws to 10 Nm!

- 1 Heater unit
- 2 Bracket
- 3 E-jot screw [2x]

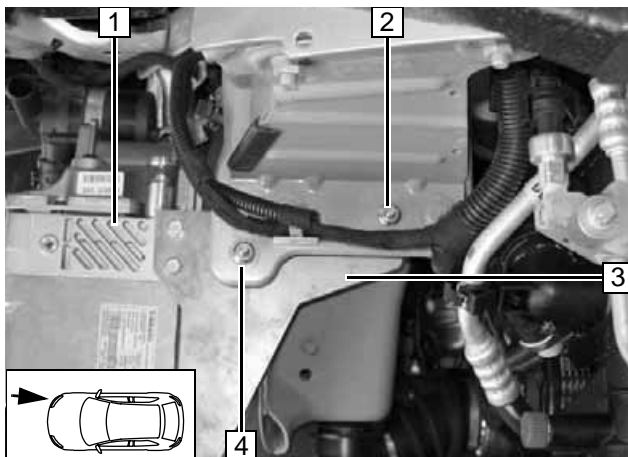
**Preparing heater unit****Installing heater unit**

- 1 Heater unit
- 3 Bracket
- 2 M6x50 bolt, 30 mm long spacer sleeve, M6 flanged nut
- 4 M6x50 bolt, large diameter washer, outside 22 mm, 30 mm long spacer sleeve, large diameter washer, outside 17.6 mm, M6 flanged nut

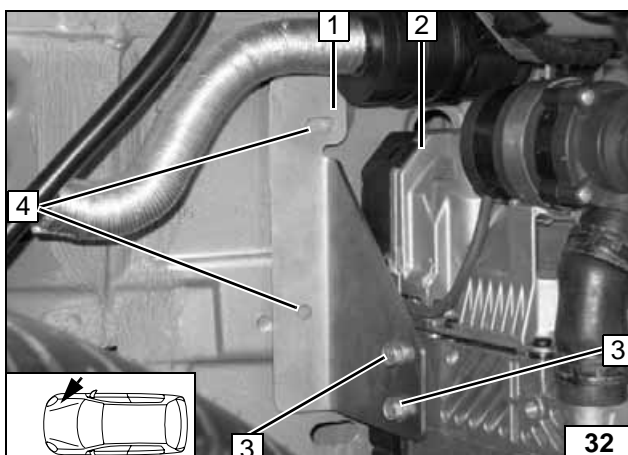
Installing heater unit

- 1 Loosely mount bracket
- 2 Heater unit
- 3 E-jot screw [2x]
- 4 Copy hole pattern, drill 9 mm hole [2x]

Installing heater unit

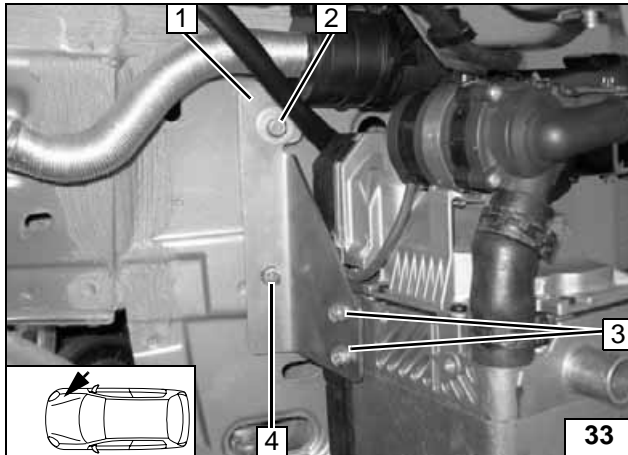
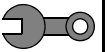

Install bracket **1** on heater unit again.
Tighten E-JOT screws to 10 Nm!

- 2** M6x20 bolt, spring lockwasher, large diameter washer, M6 rivet nut
- 3** E-jot screw [2x]
- 4** M6x20 screw, spring lock washer, M6 rivet nut



**Installing
heater unit**

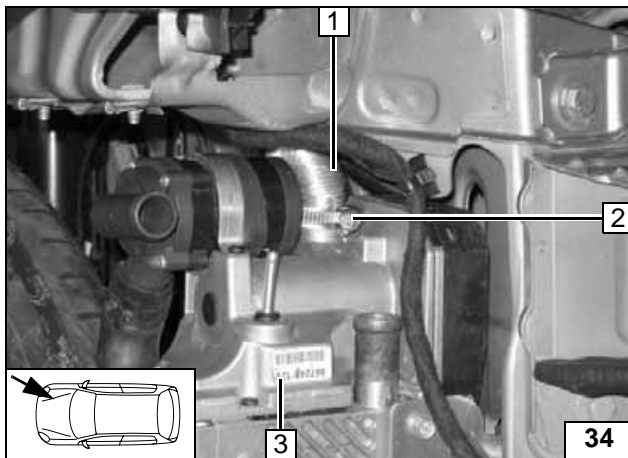

- 1** Flexible tube
- 2** 27 mm dia. clamp
- 3** Heater unit

**Installing
combustion-air in-
take pipe**



Fuel Connection

CAUTION!

Open the vehicle's fuel tank cap, ventilate the tank and then re-close the tank lock.

Catch any fuel running off with an appropriate container.

Install fuel line and metering-pump wiring harness so that they are protected against stone impact. Unless specified otherwise, always fasten using cable ties.

Mount the fuel line and wiring harness with rub protection on sharp edges.

WARNING!

The fuel line and wiring harness are routed to the metering pump in as shown in the wiring harness routing diagram.

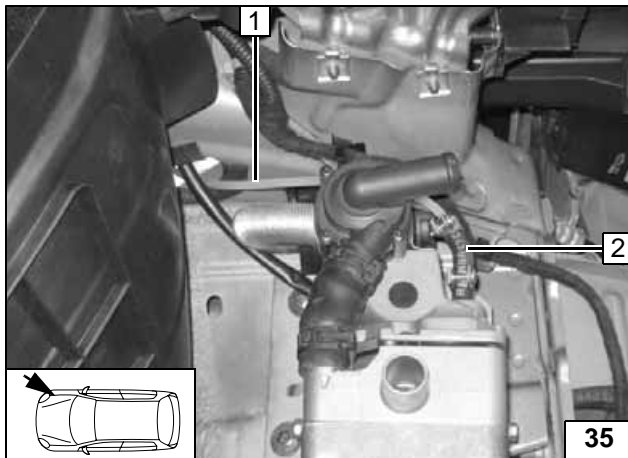

- (1) Mecanyl fuel line
- (2) Hose section, 10 mm dia. hose clamp [2x]

Conne-
ction on
heater unit

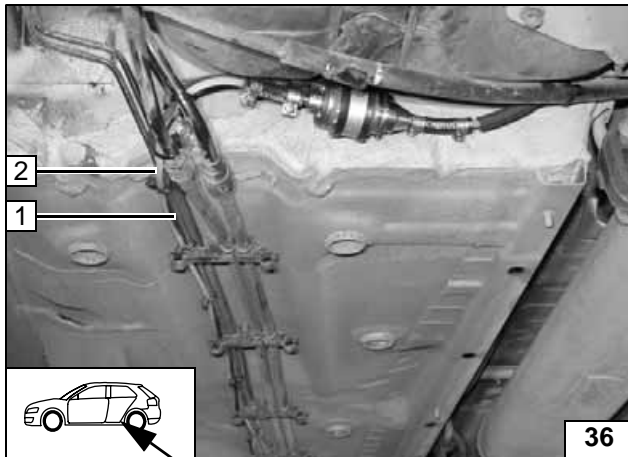

- (2) Mecanyl fuel line
- (1) Metering pump wiring harness

Install-
ing
lines

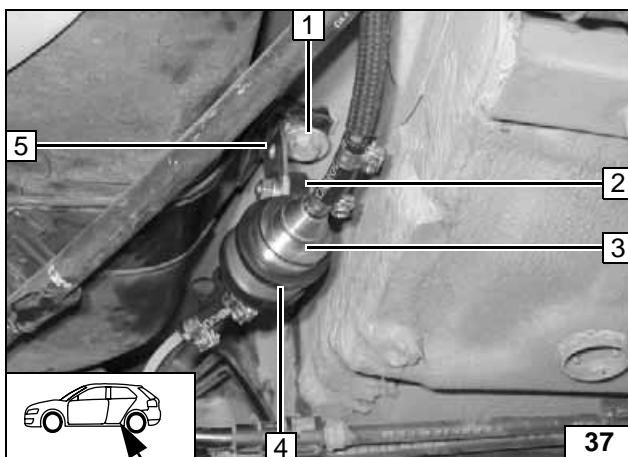

Metering pump

Ensure proper installation position of metering pump, see "Installation Instructions".

Installation location on left in front of vehicle fuel tank!

- (5) Angle bracket, drill out to 8.5 mm dia. on short leg
- (1) Original vehicle bolt
- (4) Rubber-coated p-clamp
- (3) Metering pump
- (2) Silent block, flanged nut [2x]



Install-
ation loca-
tion of
metering
pump

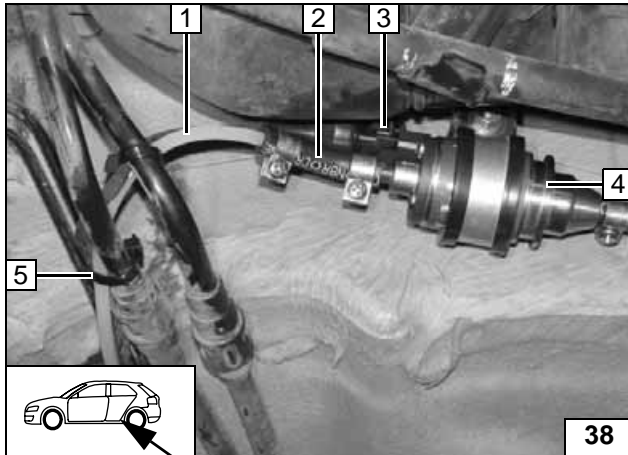

Fuel line from heater unit 1 on pressure side of metering pump 4.

- (2) Hose section, 10 mm dia. hose clamp [2x]
- (3) Wiring harness of metering pump, connector mounted
- (5) Cable tie



Connection to metering pump

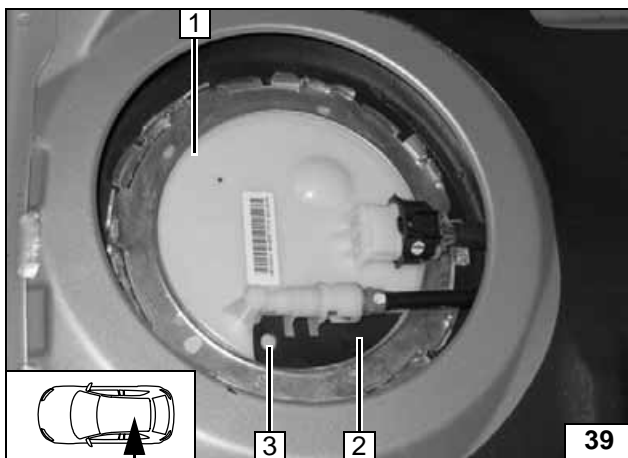

Removing fuel

Vehicles with single-line system

Detach cover of fuel-tank sending unit and lay slightly to side for drilling. Watch for chips when drilling!

- (1) Fuel-tank sending unit
- (2) Lay on template
- (3) Copy hole pattern, 6 mm dia. hole



Preparing fuel-tank sending unit

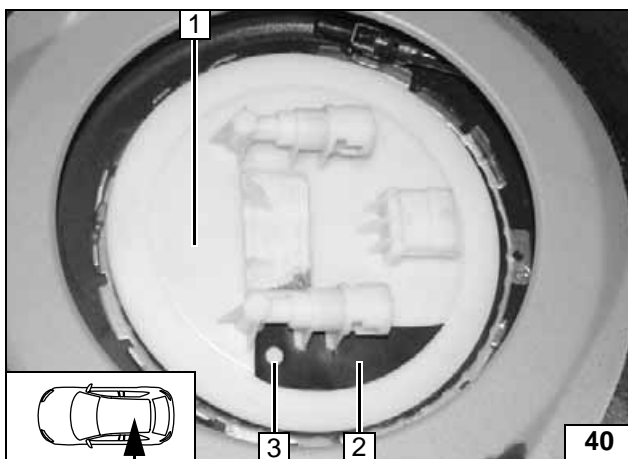

Vehicles with two line system except Z17DTR/A17DTR and Z17DTJ/A17DTJ

Detach cover of fuel-tank sending unit and lay slightly to side for drilling. Watch for chips when drilling!

- (1) Fuel-tank sending unit
- (2) Lay on template
- (3) Copy hole pattern, 6 mm dia. hole



Preparing fuel-tank sending unit

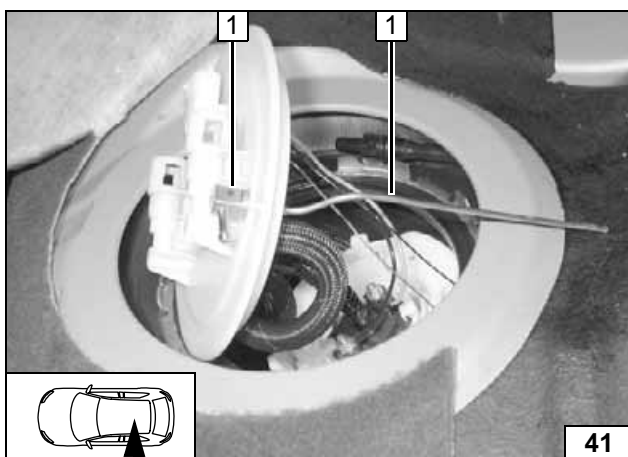

Shape fuel standpipe 1 according to template, cut to length and install, see "installation instructions".



Installing fuel standpipe

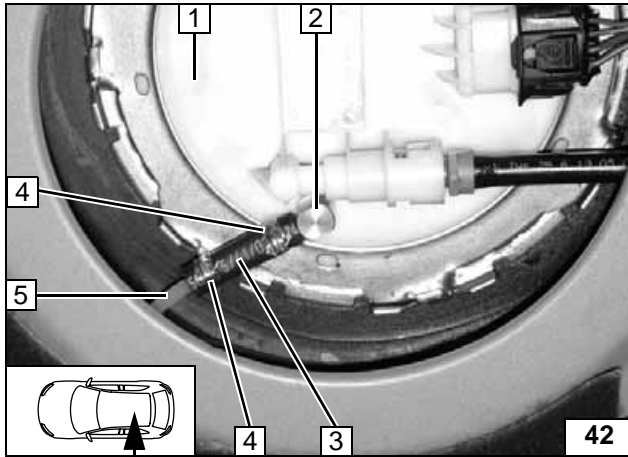

Install fuel-tank sending unit according to manufacturer's specifications.

- (1) Fuel-tank sending unit
- (2) Fuel standpipe
- (5) Remaining section of Mecanyl fuel line
- (3) Hose section
- (4) 10 mm dia. Caillau clamp [2x]



Connect-
ing fuel
line

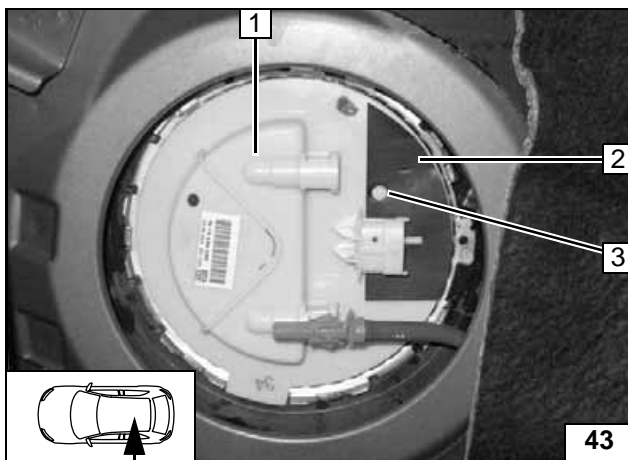

**1.7 liter diesel Z17DTR/A17DTR
and Z17DTJ/A17DTJ**

Detach cover of fuel-tank sending unit 1 and lay slightly to side for drilling. Watch for chips when drilling!

- (2) Lay on template
- (3) Copy hole pattern, 6 mm dia. hole



Preparing
fuel-tank
sending
unit

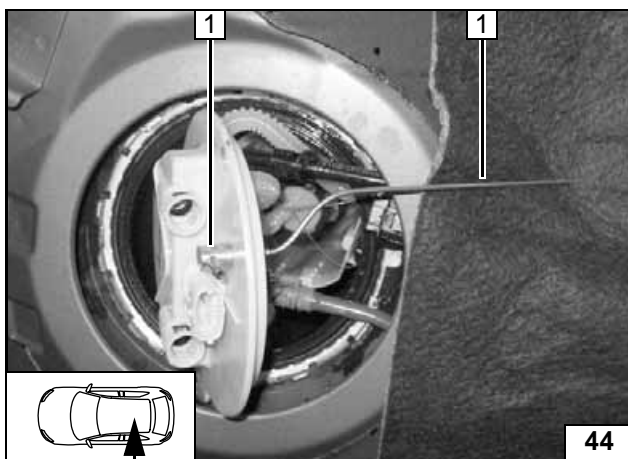

Shape fuel standpipe 1 according to template, cut to length and install, see "installation instructions".



Installing
fuel
standpipe

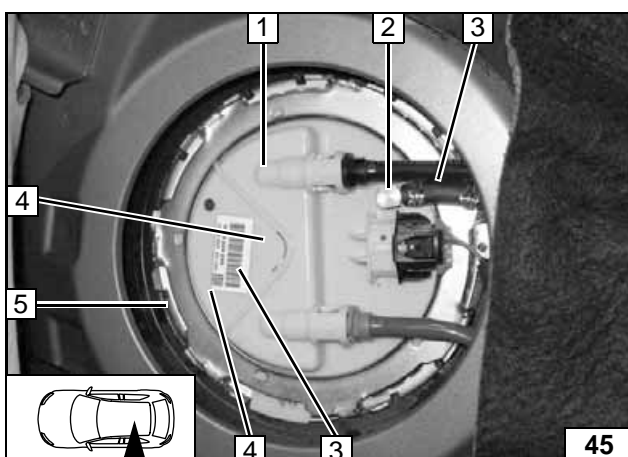

Install fuel-tank sending unit 1 in accordance with manufacturer's specifications.

- (2) Fuel standpipe
- (3) Fuel line, hose section, 10 mm dia. Caillau clamp [2x]



Connect-
ing fuel
line

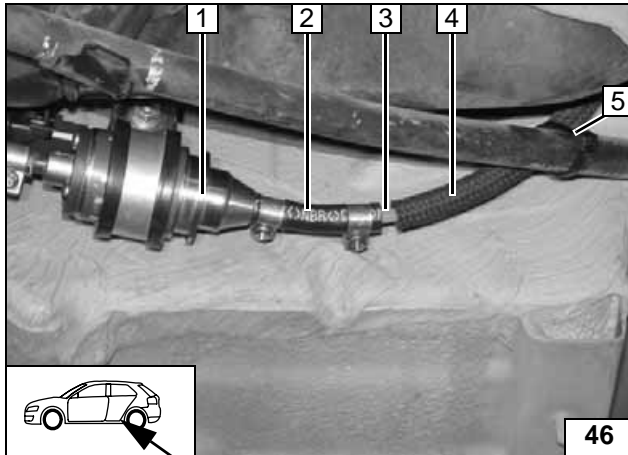

Fuel line from fuel standpipe **3** on intake side of metering pump **1**. Push fuel hose **4** as protective hose onto fuel line **3**. Check the position of the components; adjust if necessary. Check that they have free clearance.

(2) Hose section, 10 mm dia. hose clamp [2x]
(5) Cable tie



**Connec-
tion to me-
tering
pump**



Diagram for coolant of 1.4 liter; 2.0 liter gasoline



WARNING!

Tighten all hose clamps to 2.0 + 0.5 Nm.

Any coolant running off should be collected using an appropriate container!

Install hoses so that they are kink-free. Unless specified otherwise, always fasten using cable ties.

Position hose clamps and spring band clamps so that no other hose can be damaged.

The connection should be "inline" based on the following diagram:

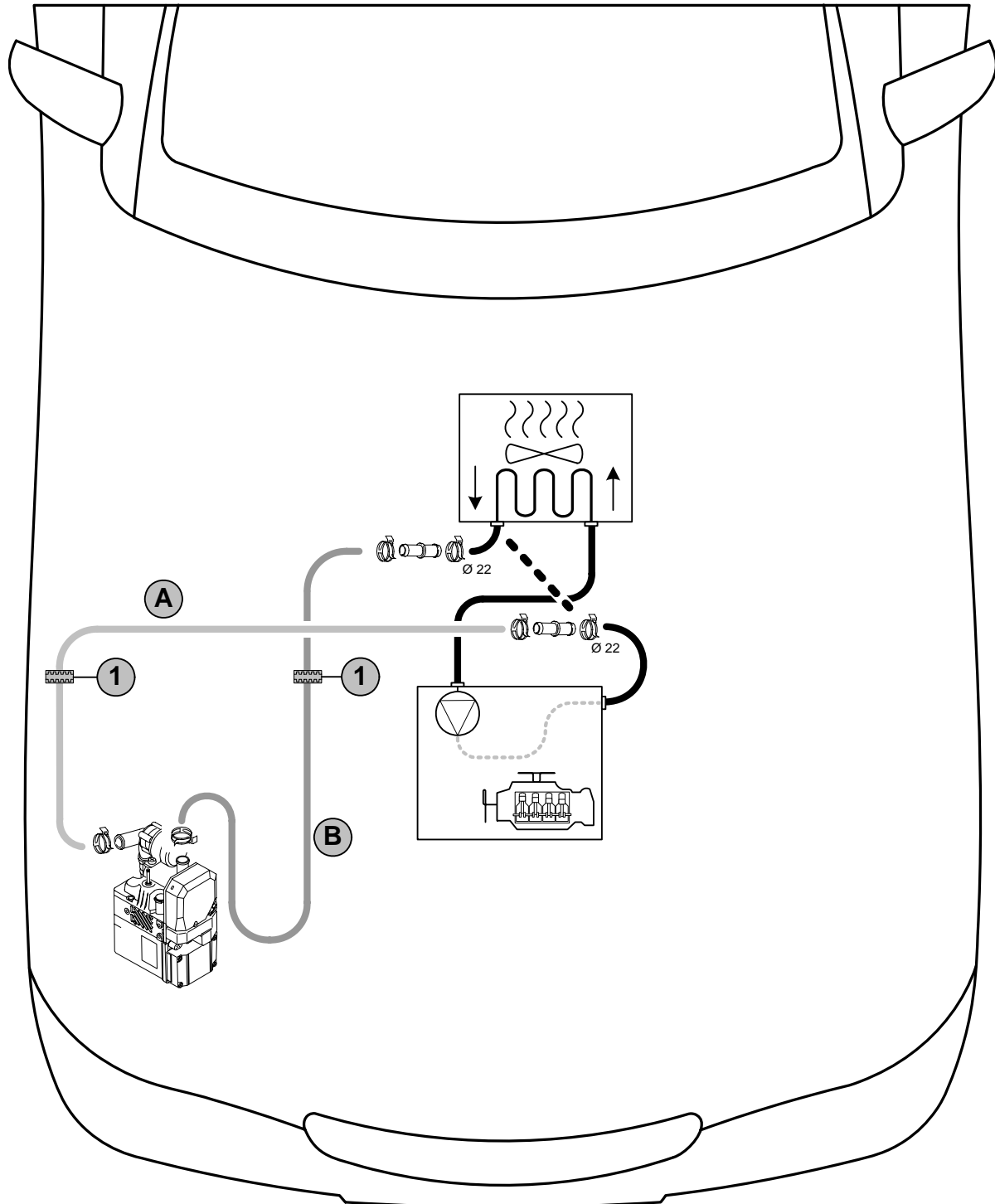

Coolant
Diagram

All spring clips without a specific designation = 27 mm dia.

All connecting pipes 15x20!

1 = Black (sw) rubber isolator [2x] only with 2.0 liter gasoline!

Diagram for coolant of 1.6 liter Z16XEP; 1.8 liter gasoline and 1.3 liter; 1.7 liter diesel

WARNING!

Tighten all hose clamps to 2.0 + 0.5 Nm.

Any coolant running off should be collected using an appropriate container!

Install hoses so that they are kink-free. Unless specified otherwise, always fasten using cable ties.

Position hose clamps and spring band clamps so that no other hose can be damaged.

The connection should be "inline" based on the following diagram:

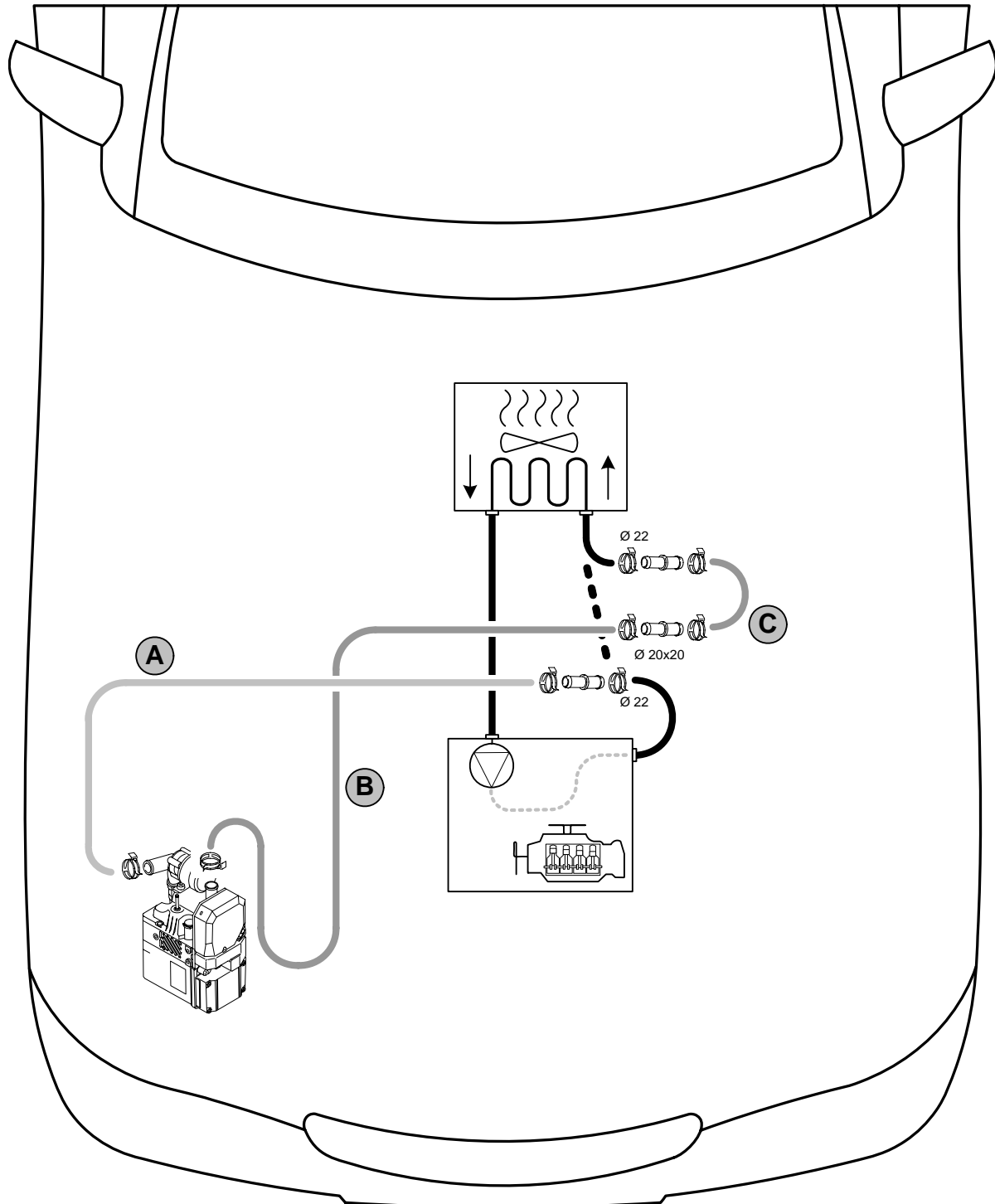
Coolant Diagram

All spring clips without a specific designation = 27 mm dia.
 All connecting pipes without a specific designation = 15x20!



Diagram for coolant of 1.6 liter Z16XER



WARNING!

Tighten all hose clamps to 2.0 + 0.5 Nm.

Any coolant running off should be collected using an appropriate container!

Install hoses so that they are kink-free. Unless specified otherwise, always fasten using cable ties.

Position hose clamps and spring band clamps so that no other hose can be damaged.

The connection should be "inline" based on the following diagram:

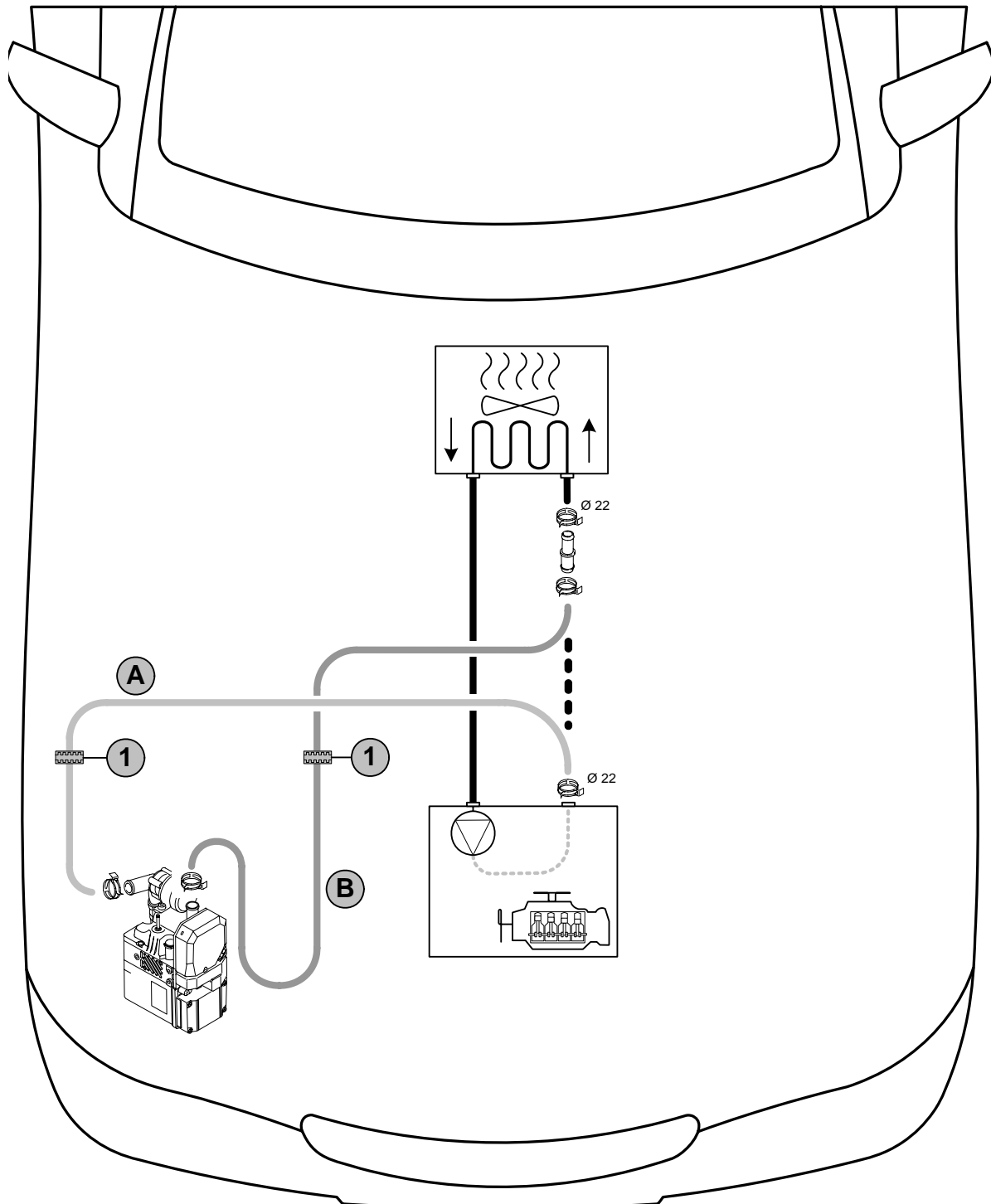

Coolant
Diagram

All spring clips without a specific designation = 27 mm dia.
Connecting pipe 15x20! 1 = Black (sw) rubber isolator [2x]



Diagram for coolant of 1.6 liter Z16LET



WARNING!

Tighten all hose clamps to 2.0 + 0.5 Nm.

Any coolant running off should be collected using an appropriate container!

Install hoses so that they are kink-free. Unless specified otherwise, always fasten using cable ties.

Position hose clamps and spring band clamps so that no other hose can be damaged.

The connection should be "inline" based on the following diagram:

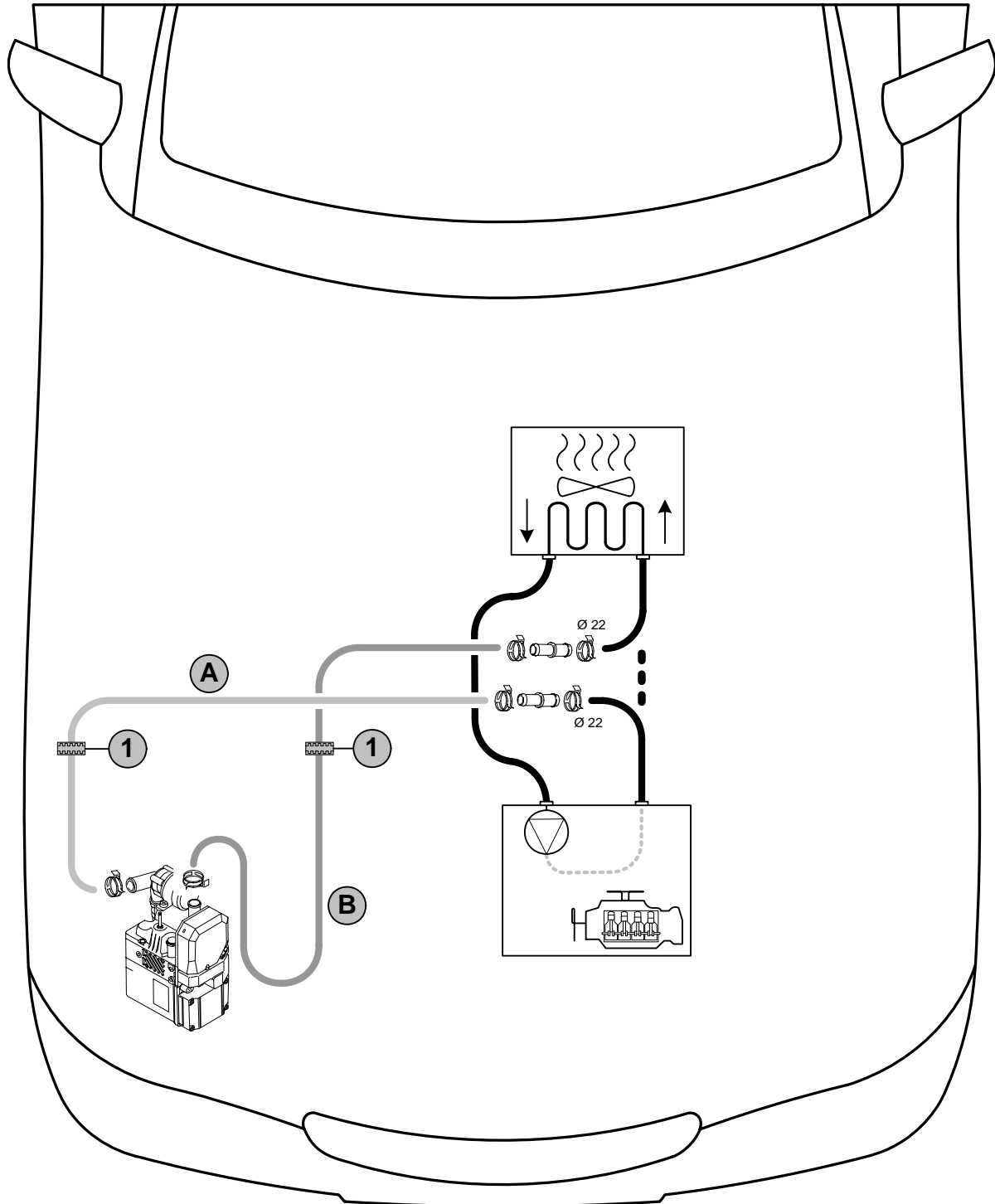

Coolant
Diagram

All spring clips without a specific designation = 27 mm dia.

Connecting pipe 15x20!

1 = Black (sw) rubber isolator [2x]



Diagram for coolant of 1.9 liter diesel



WARNING!

Tighten all hose clamps to 2.0 + 0.5 Nm.

Any coolant running off should be collected using an appropriate container!

Install hoses so that they are kink-free. Unless specified otherwise, always fasten using cable ties.

Position hose clamps and spring band clamps so that no other hose can be damaged.

The connection should be "inline" based on the following diagram:

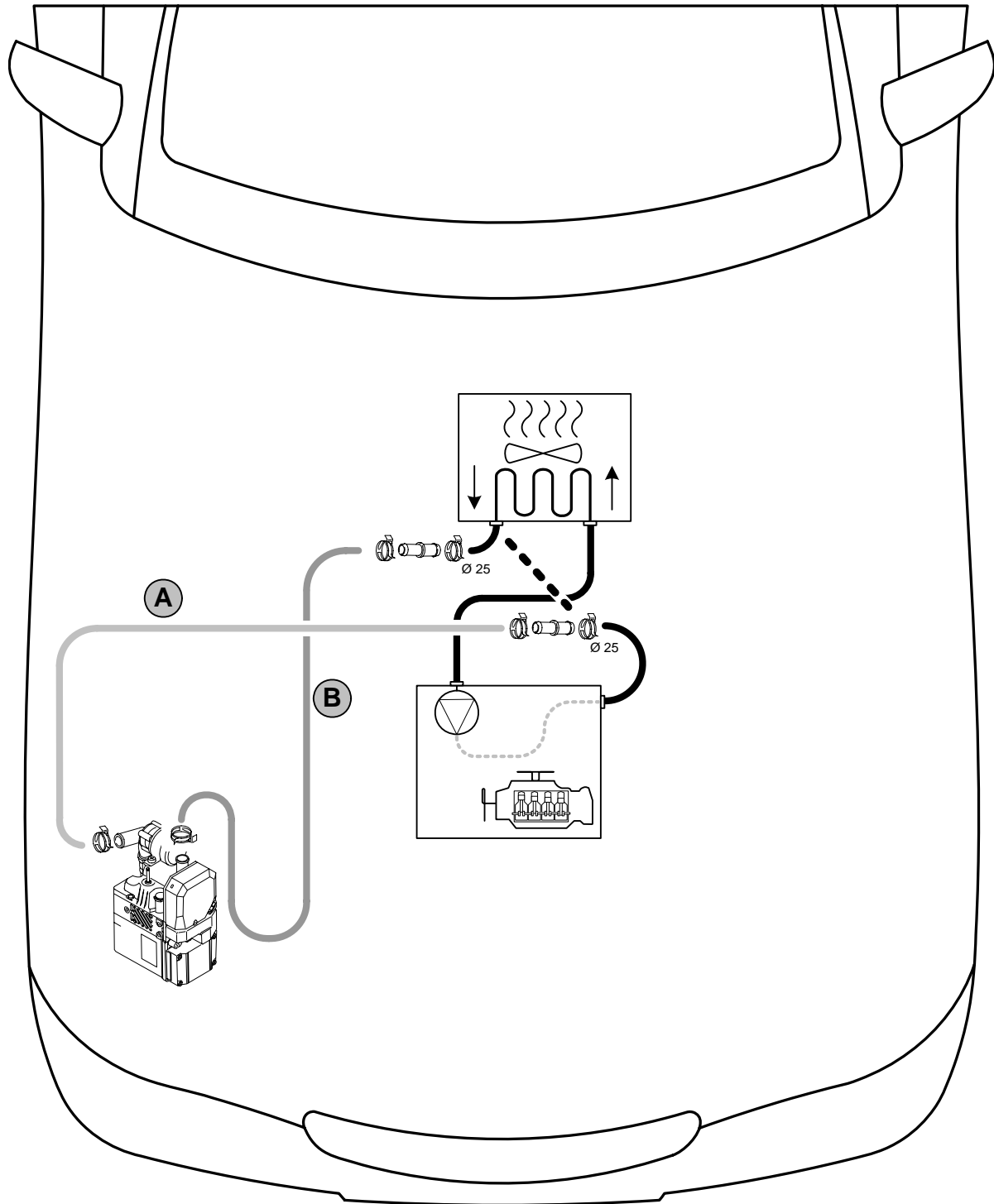

Coolant
Diagram

All clamps without a specific designation = 27 mm dia. spring clips!

All connecting pipes 18x20!

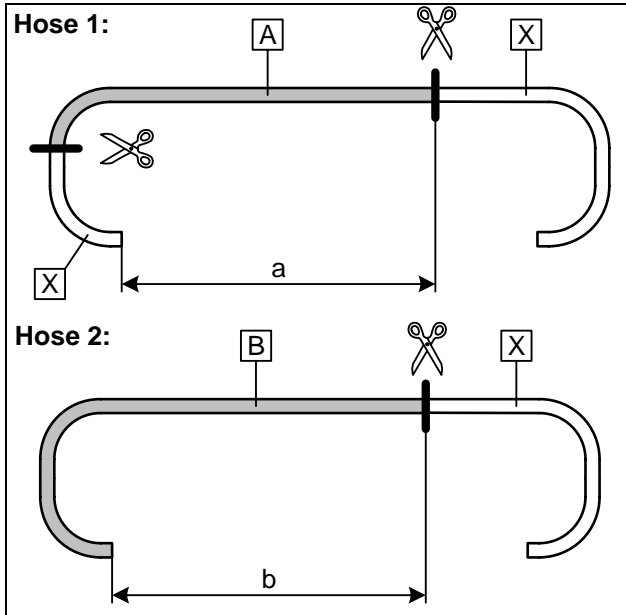

Cutting coolant hoses to length

1.4 liter gasoline

Cut away hose **A** just behind elbow.

a = 1,600 mm
b = 1,500 mm

Discard section **X**



Cutting coolant hoses to length

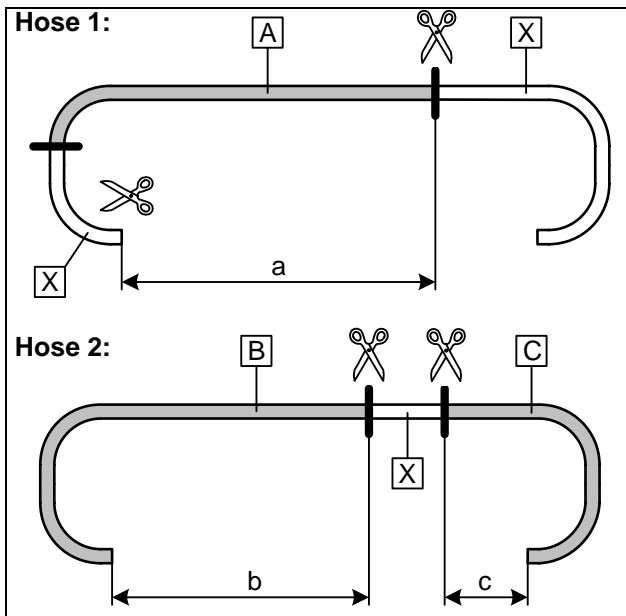

1.6 liter gasoline Z16XEP

Cut away hose **A** just behind elbow.

a = 1,600 mm
b = 1,600 mm
c = 100 mm

Discard section **X**



Cutting coolant hoses to length

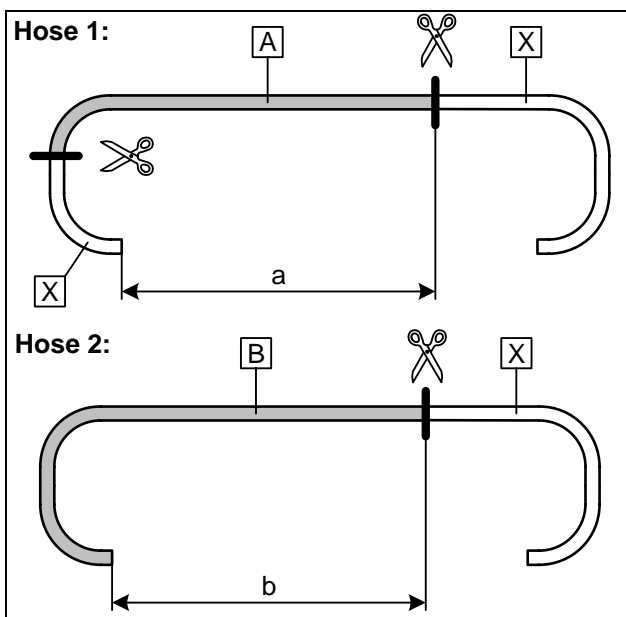

1.6 liter gasoline Z16XER

Cut away hose **A** just behind elbow.

a = 1,800 mm
b = 1,460 mm

Discard section **X**



Cutting coolant hoses to length

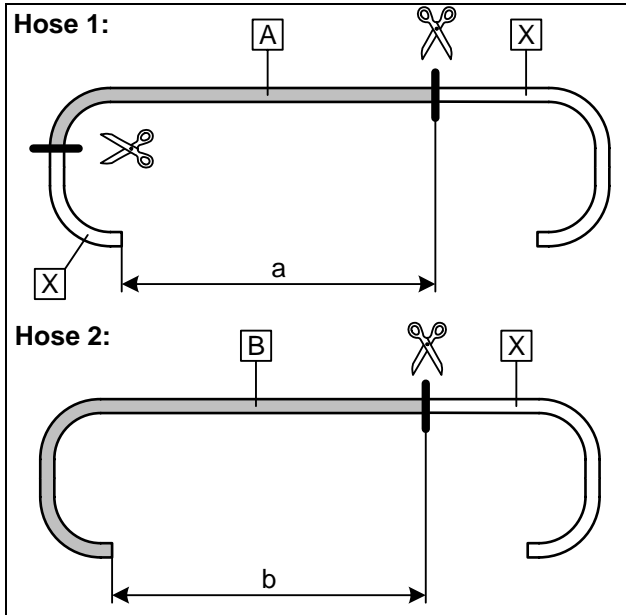

1.6 liter gasoline Z16LET

Cut away hose **A** just behind elbow.

a = 1,440 mm
b = 1,280 mm

Discard section **X**



Cutting coolant hoses to length

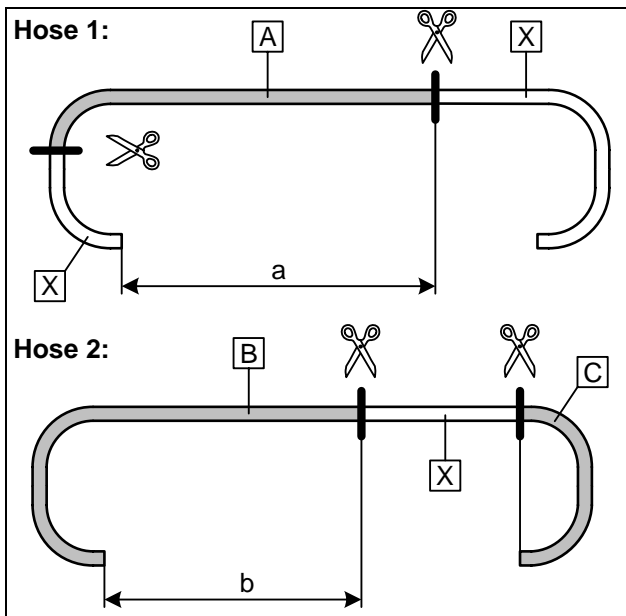

1.8 liter gasoline

Cut away hose **A** just behind elbow.

a = 1,700 mm
b = 1,600 mm

Discard section **X**



Cutting coolant hoses to length

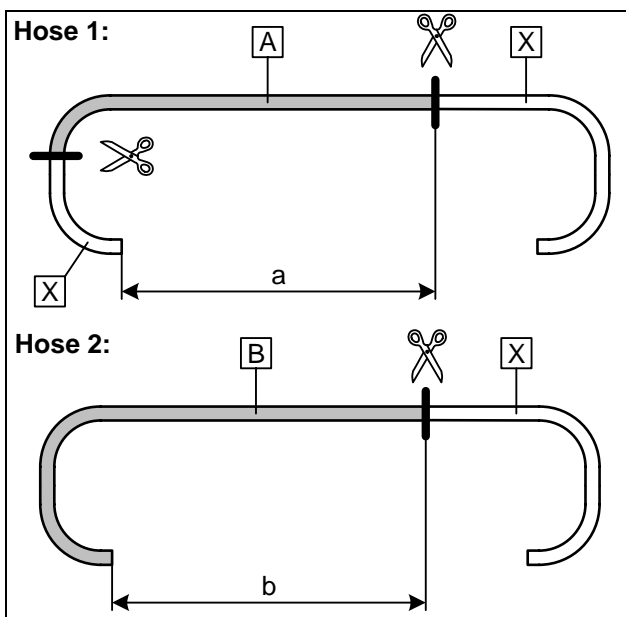

2.0 liter gasoline

Cut away hose **A** just behind elbow.

a = 1,400 mm
b = 1,300 mm

Discard section **X**



Cutting coolant hoses to length

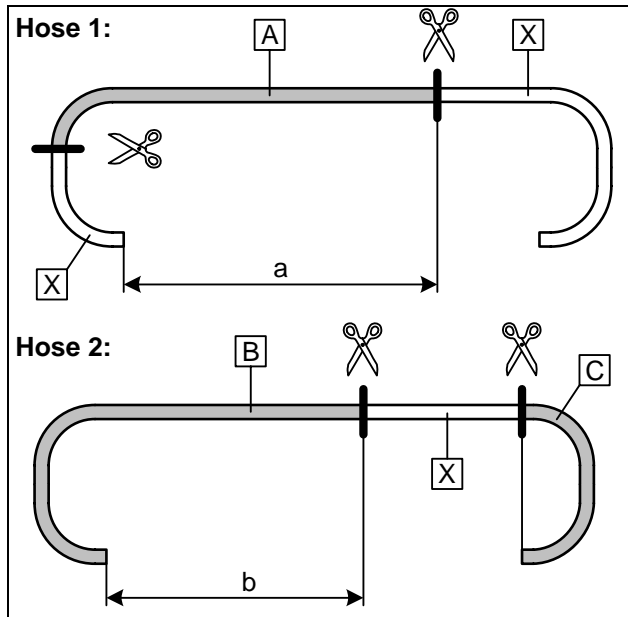

1.3 liter and 1.7 liter diesel

Cut away hose **A** just behind elbow.

a = 1,700 mm
b = 1,550 mm

Discard section **X**



Cutting coolant hoses to length

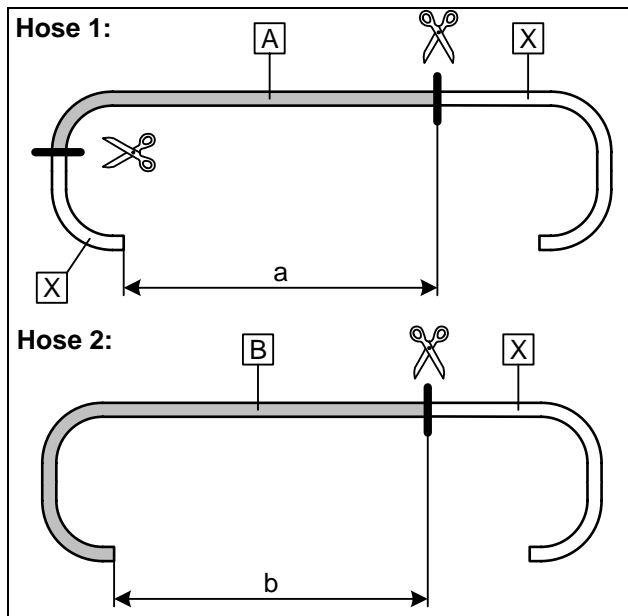

1.9 liter Diesel

Cut away hose **A** just behind elbow.

a = 2,000 mm
b = 1,520 mm

Discard section **X**



Cutting coolant hoses to length

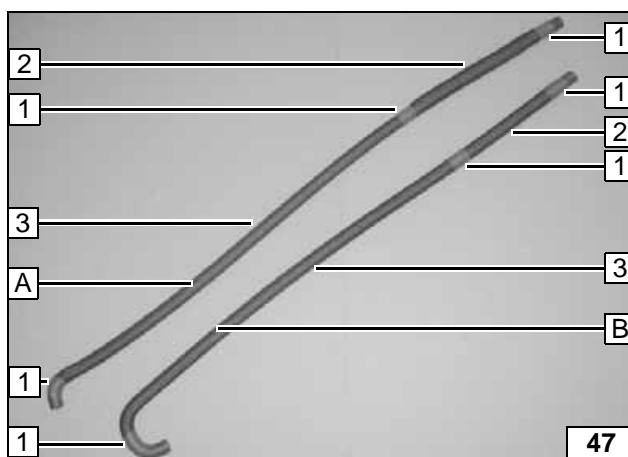

Preparing coolant hoses

Divide braided protection hose in center.

- (3) Braided protection hose complete [2x]
- (2) Braided protection hose cut to length [2x]
- (1) Cut heat shrink plastic tubing [6x] in center



Preparing coolant

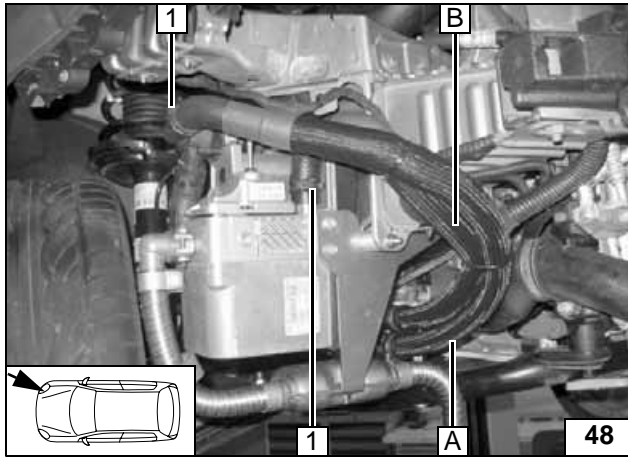

Installing coolant hoses

All vehicles

- 1 27 mm dia. spring clip [2x]

Conne-
ction on
heater unit

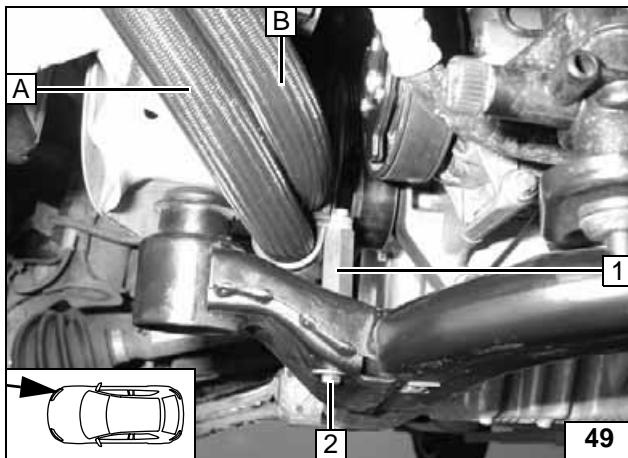

- (1) 40 mm spacer nut, rubber-coated p-clamp [2x], M6x20 bolt, spring lockwasher
- (2) M6x50 bolt, spring lockwasher, large diameter washer

Fastening
on engine
support

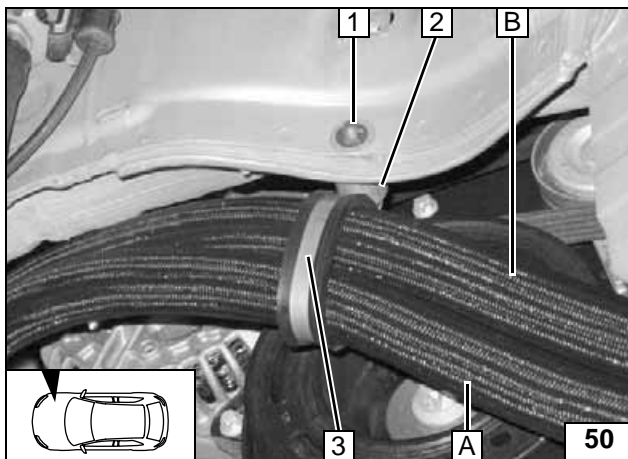

All vehicle except 2.0 liter gasoline

- (1) M6x50 bolt (engine side to wheel well), large diameter washer, pin lock
- (2) 20 mm shim
- (3) 48 mm dia. rubber-coated p-clamp

Fastening
on frame
side
member

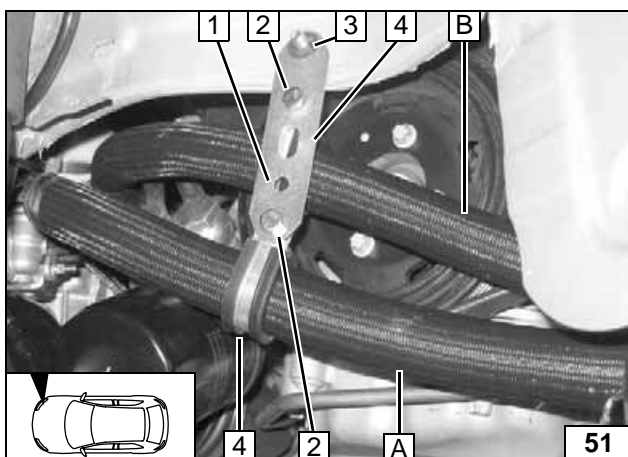

2.0 liter gasoline

- (1) Perforated bracket
- (3) M6x20 bolt (engine side to wheel well), pin lock
- (2) M6x20 bolt (wheel well to engine side), flanged nut [2x each]
- (4) 29 mm dia. rubber-coated p-clamp [2x]

Fastening
on frame
side
member

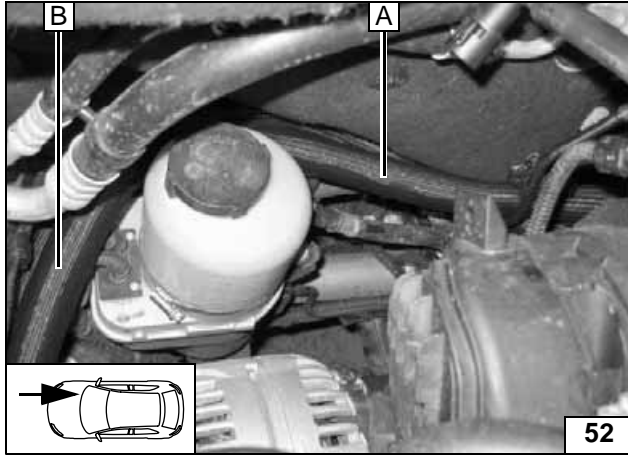

Coolant connection

1.4 liter gasoline

Route coolant hose to cutting point.



Routing in engine compartment

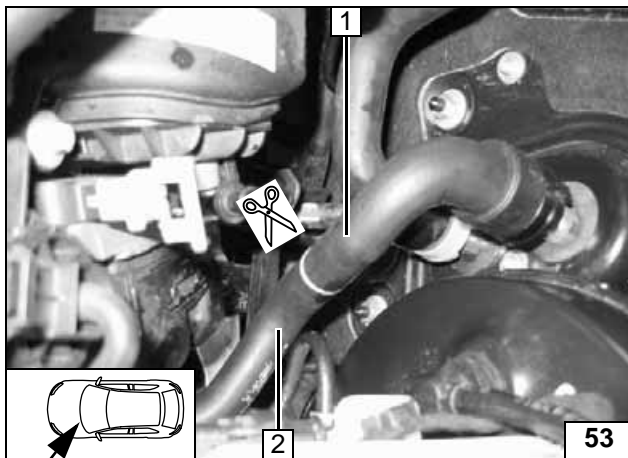

- (1) Hose section on heat exchanger inlet
- (2) Hose section on engine outlet

Cutting point

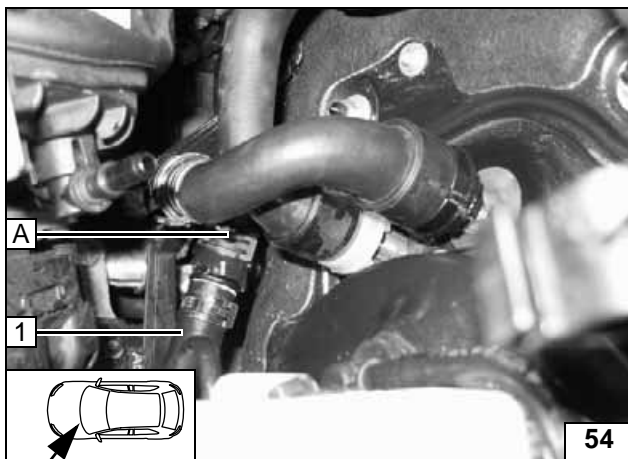

- (1) Hose on engine outlet

Connection to engine outlet

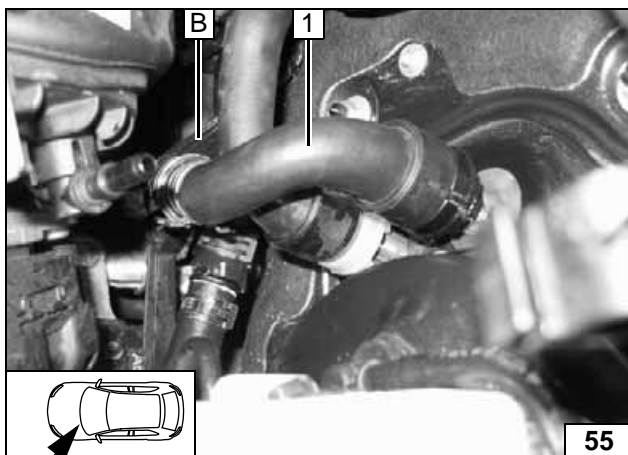

Before connecting, fill the water hoses with coolant.

- (1) Hose on heat exchanger inlet



Connection to heat exchanger inlet

Align hoses **A** and **B** over entire length and fix in place with cable ties.



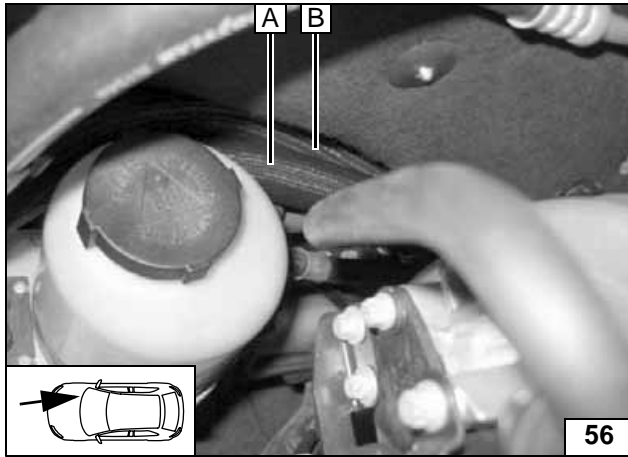

1.6 liter gasoline Z16XEP

Route coolant hose to cutting point.



Routing in engine compartment

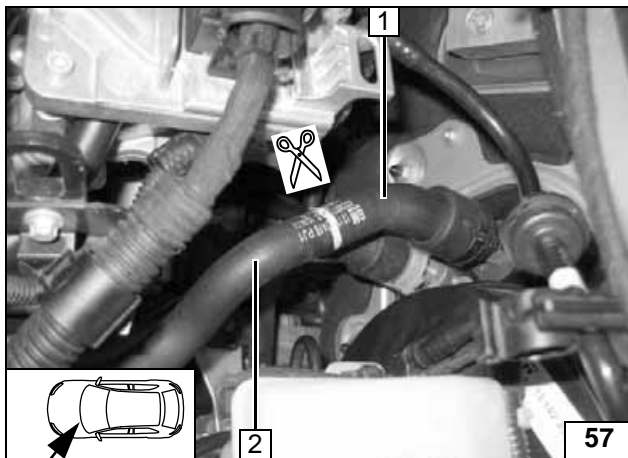

- (1) Hose section on heat exchanger inlet
- (2) Hose section on engine outlet

Cutting point

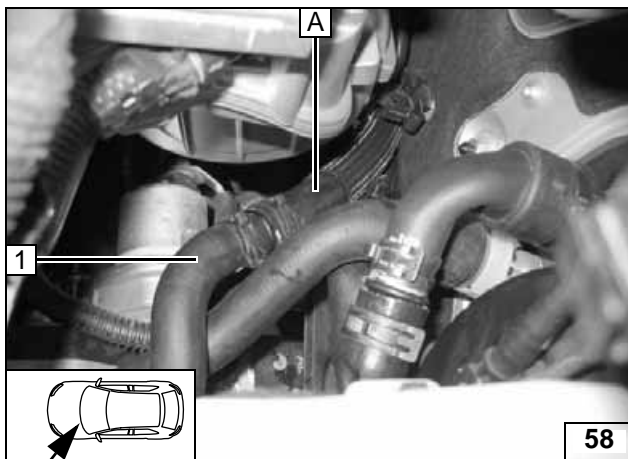

- (1) Hose on engine outlet

Connection to engine outlet

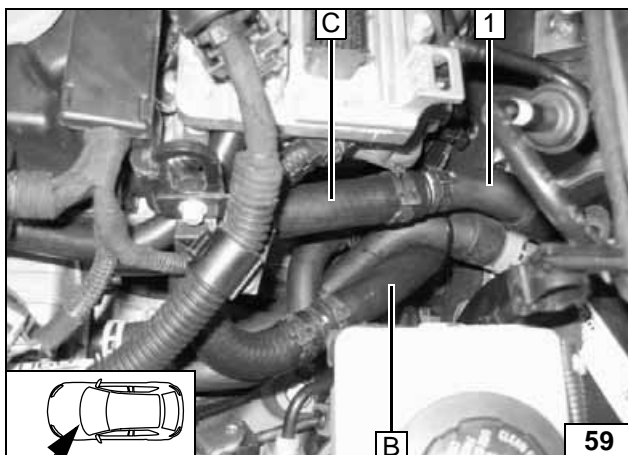

Before connecting, fill the water hoses with coolant.

Long side of 180° elbow on hose (1)!

- (1) Hose on heat exchanger inlet



Connection to heat exchanger inlet

Align hose A, B and C over entire length and fix in place with cable ties.



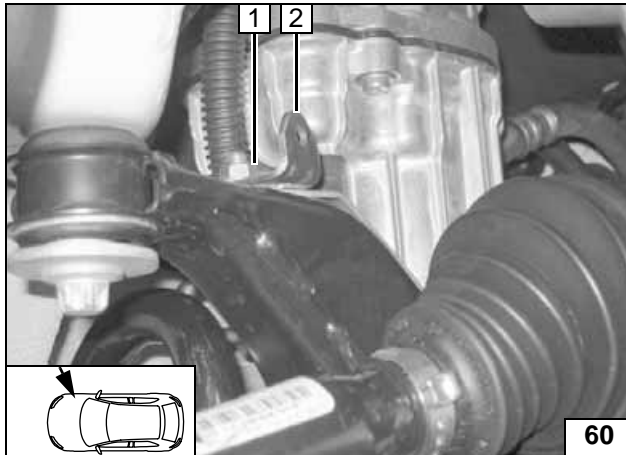

1.6 liter gasoline Z16XER

- (1) Original vehicle nut
- (2) Angle bracket



Routing in engine compartment

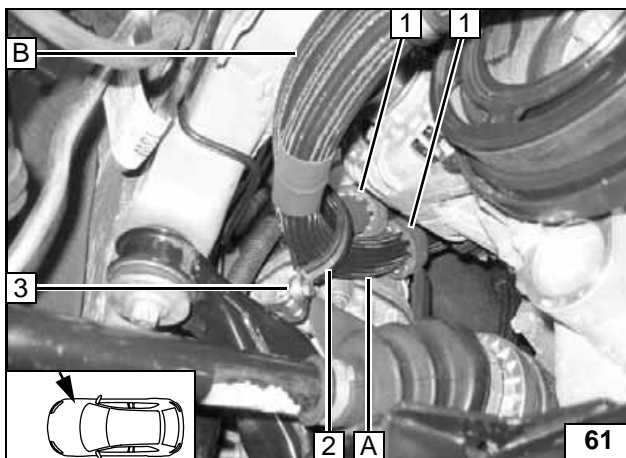

- (1) Black (sw) rubber profile [2x]
- (2) 48 mm dia. rubber-coated p-clamp
- (3) M6x20 bolt, flanged nut

Routing in engine compartment

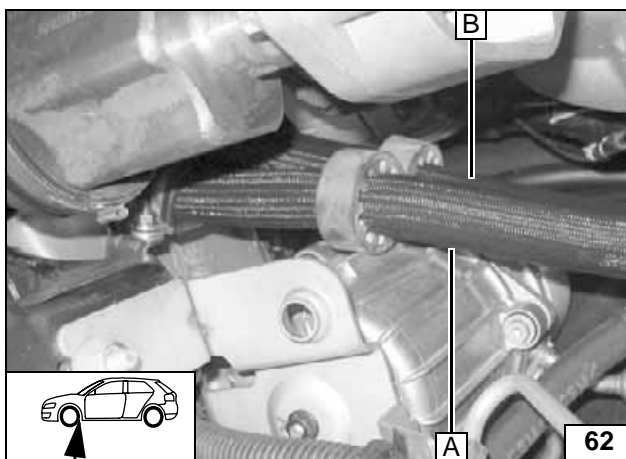

Position rubber profiles as shown



Routing in engine compartment

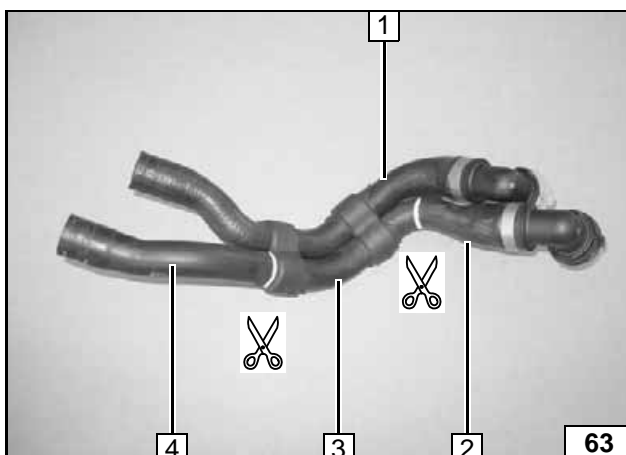

Remove engine/heat exchanger hose group 1 and cut off at markings. Center section 3 is vulcanized on and remains on hose group (without function)!

- (1) Reinstall engine/heat exchanger hose group
- (2) Reinstall hose section on engine outlet
- (4) Discard hose section



Cutting point

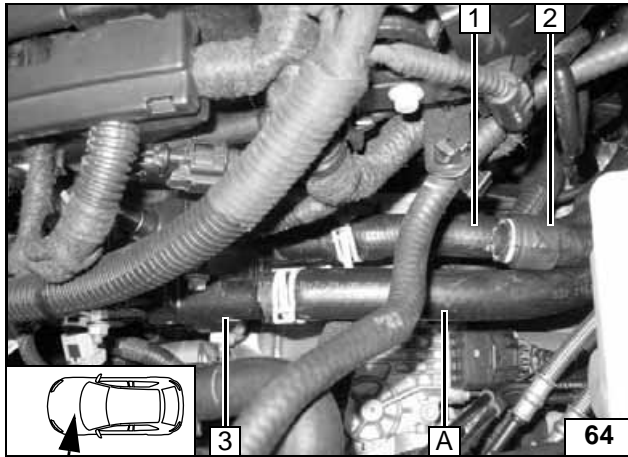

- (1) Engine/heat exchanger hose group installed
- (2) Center section of hose group (without function)
- (3) Connection piece on engine outlet

Conne-
ction to en-
gine outlet

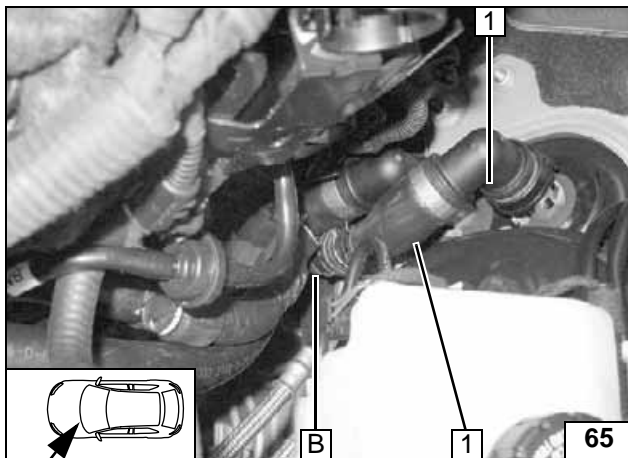

Before connecting, fill the water hoses with coolant.

- (1) Hose section on heat exchanger inlet installed

Conne-
ction to
heat ex-
changer
inlet

Align hoses **A** and **B** over entire length and fix in place with cable ties.
Align black (sw) rubber profiles.

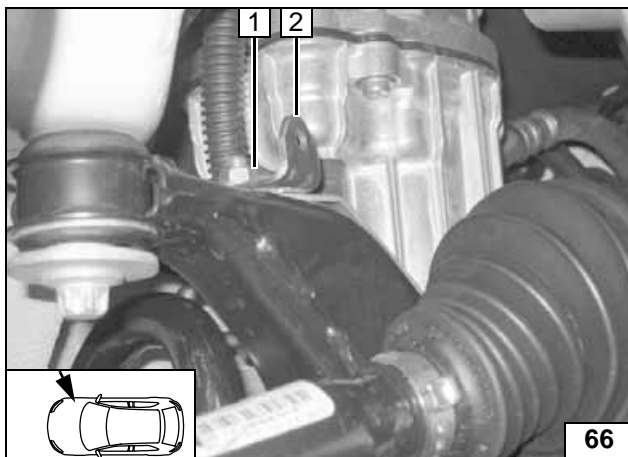

1.6 liter gasoline Z16LET

- (1) Original vehicle nut
- (2) Angle bracket

Routing in
engine
compart-
ment

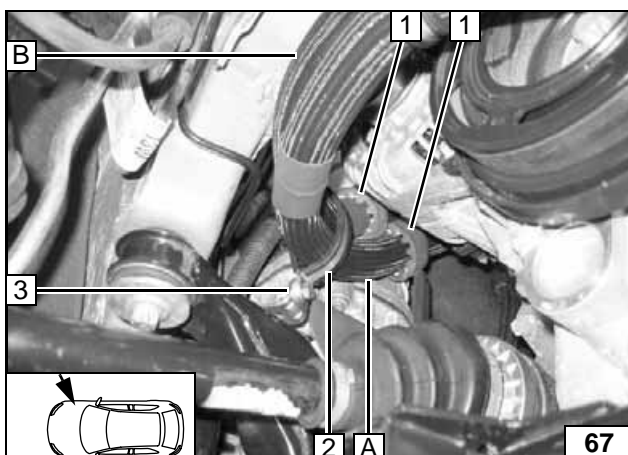

- (1) Black (sw) rubber profile [2x]
- (2) 48 mm dia. rubber-coated p-clamp
- (3) M6x20 bolt, flanged nut

Routing in
engine
compart-
ment

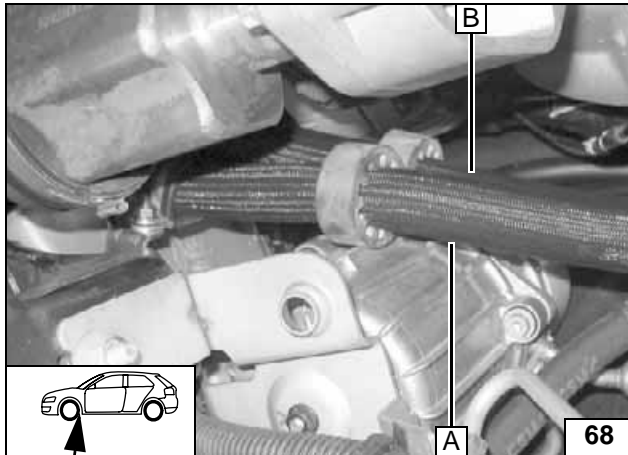

Position rubber profiles as shown



Routing in engine compartment

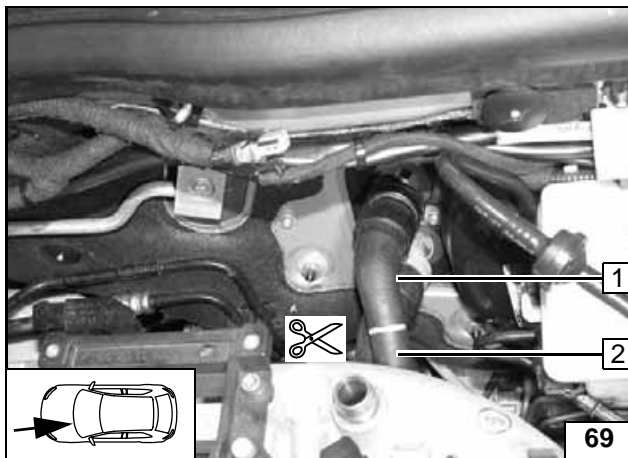

Cut off hose on engine outlet/heat exchanger inlet at marking.

- (1) Hose section on heat exchanger inlet
- (2) Hose section on engine outlet



Cutting point

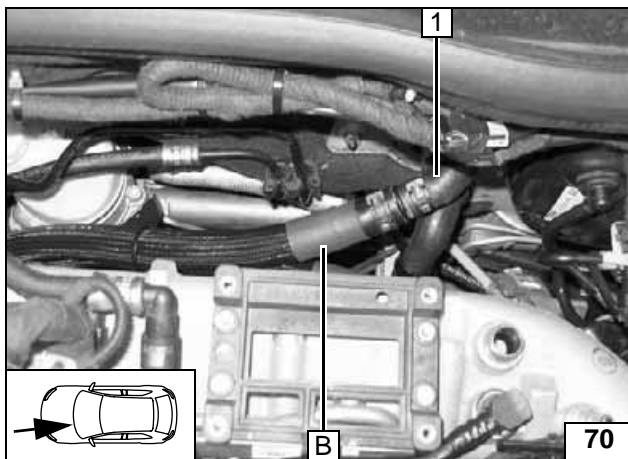

- (1) Hose section on heat exchanger inlet turned approx. 90° to right

Connection on heat exchanger inlet

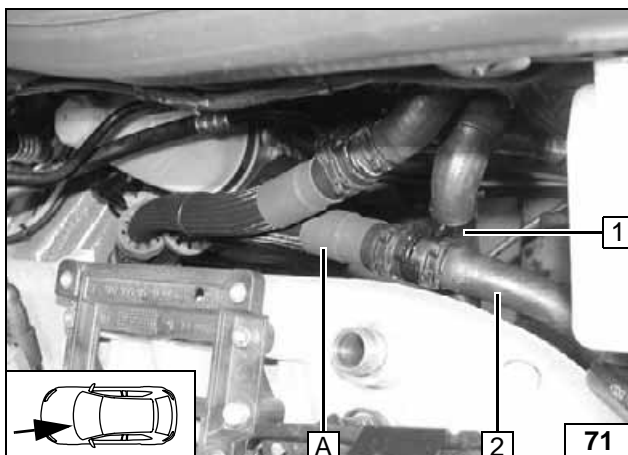

Before connecting, fill the water hoses with coolant.

- (2) Hose section on engine outlet
- (1) Insert spacer bracket



Connection to engine outlet

Align hoses **A** and **B** over entire length and fix in place with cable ties.
Align black (sw) rubber profiles.



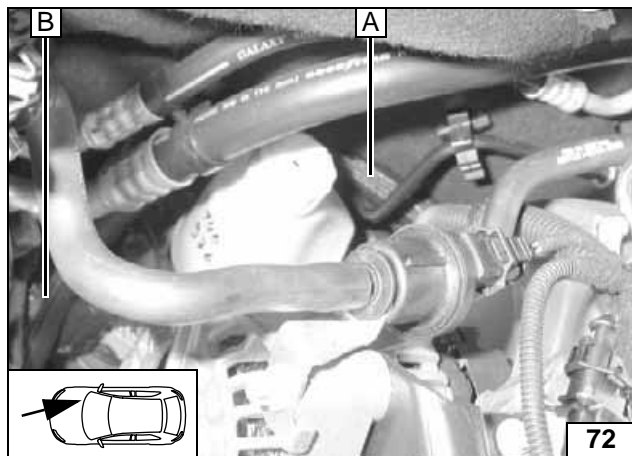
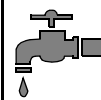

1.8 liter gasoline

Route coolant hose to cutting point.



Routing in engine compartment

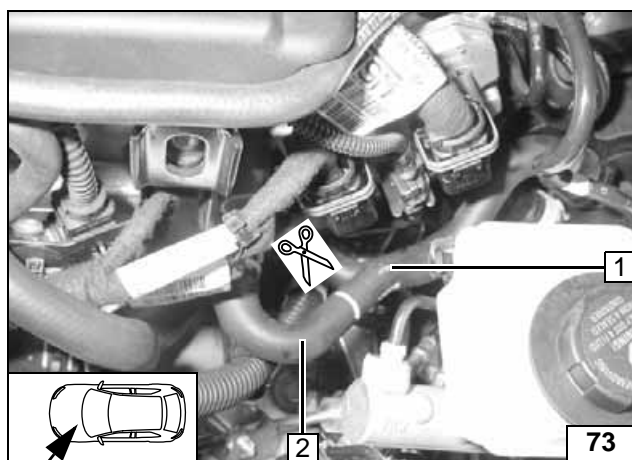

- (1) Hose section on heat exchanger inlet
- (2) Hose section on engine outlet

Cutting point

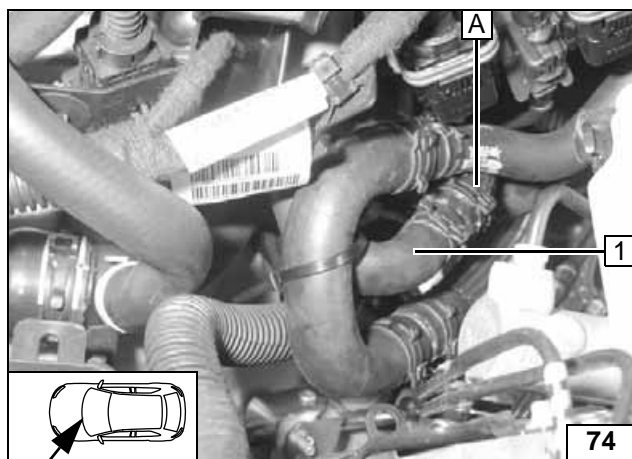

- (1) Hose on engine outlet

Connection to engine outlet

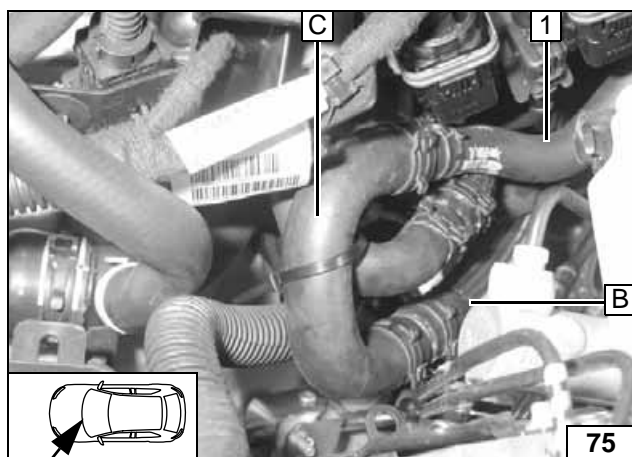

Before connecting, fill the water hoses with coolant.

Long side of 180° elbow on hose (1)!

- (1) Hose on heat exchanger inlet



Connection to heat exchanger inlet

Align hose A, B and C over entire length and fix in place with cable ties.



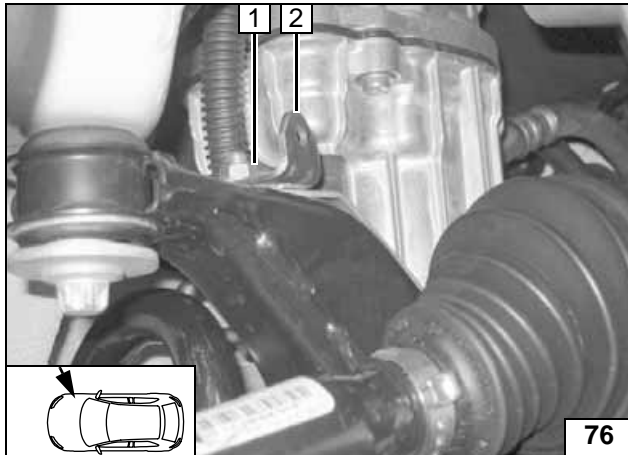

2.0 liter gasoline

- (1) Original vehicle nut
- (2) Angle bracket



Routing in engine compartment

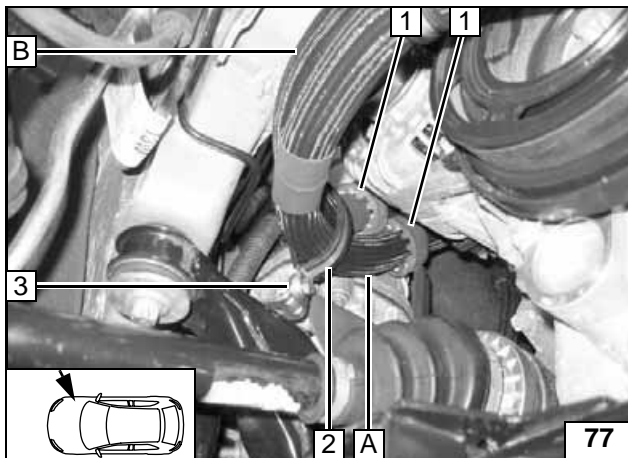

- (1) Black (sw) rubber profile [2x]
- (2) 48 mm dia. rubber-coated p-clamp
- (3) M6x20 bolt, flanged nut

Routing in engine compartment

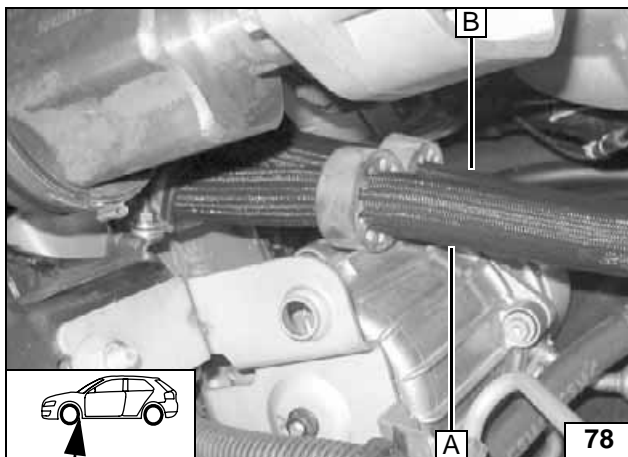

Position black (sw) rubber isolator as shown



Routing in engine compartment

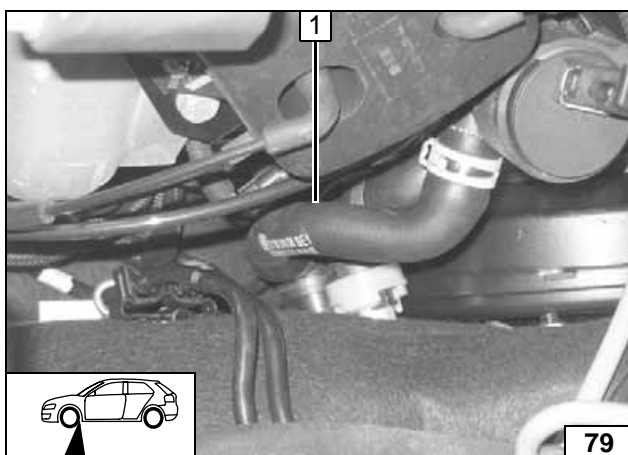

- (1) Engine outlet hose to heat exchanger inlet

Removing hose

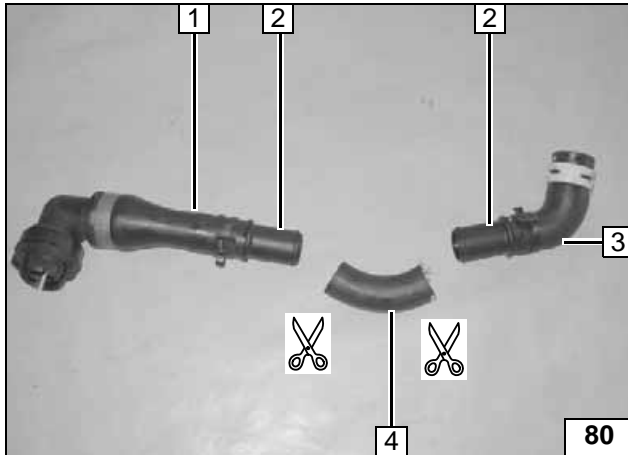

- (1) Hose section on heat exchanger inlet
- (2) 15x20 mm dia. connecting pipe; 22 mm dia. spring clip [2x]
- (3) Hose section on engine outlet
- (4) Discard section

Cutting point

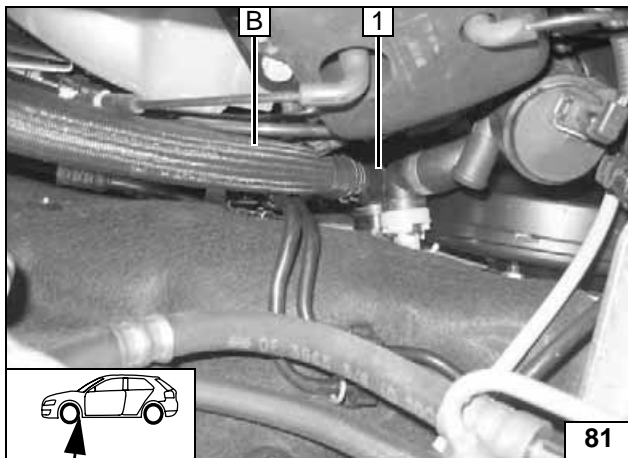

- (1) Premounted hose section on heat exchanger inlet

Connection on heat exchanger inlet

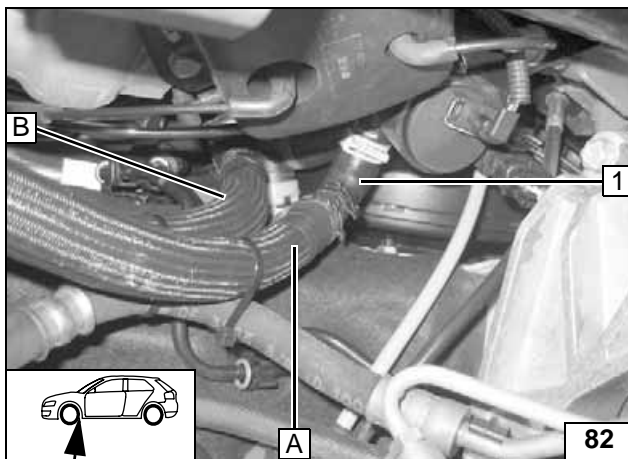

Before connecting, fill the water hoses with coolant.



- (1) Premounted hose section on engine outlet

Connection to engine outlet

Align hoses **A** and **B** over entire length and fix in place with cable ties.
Align black (sw) rubber profiles



1.3 liter diesel



Route coolant hose to cutting point.

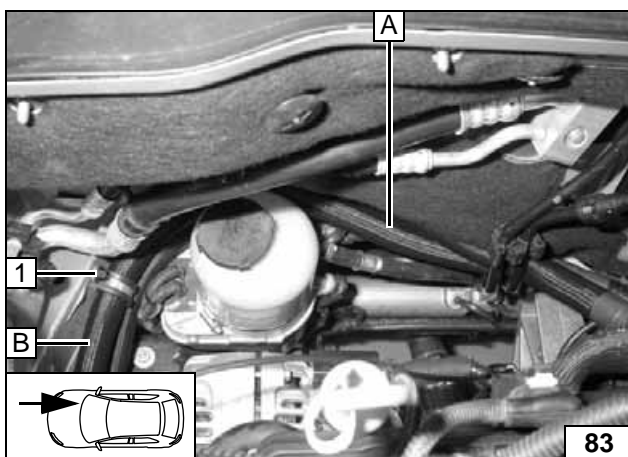

- (1) Original vehicle stud bolt, rubber-coated p-clamp, plastic nut

Routing in engine compartment

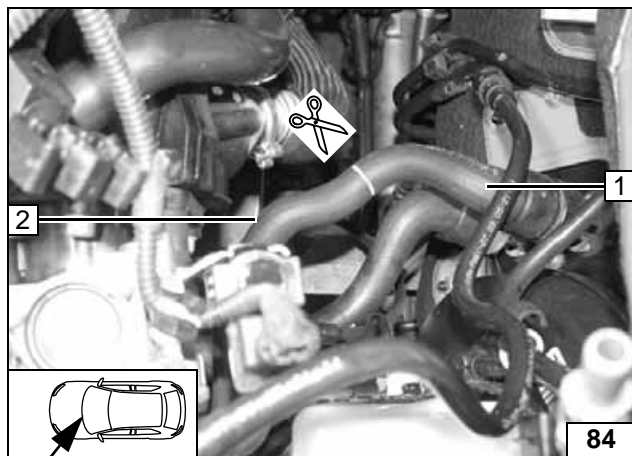
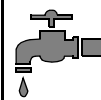

- (1) Hose section on heat exchanger inlet
- (2) Hose section on engine outlet

Cutting point

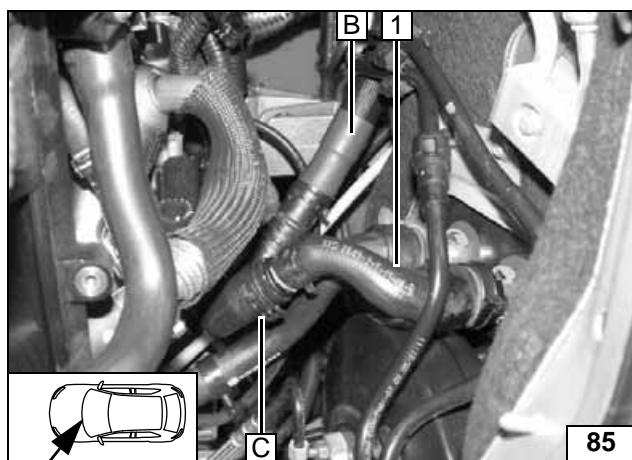

- (1) Hose on heat exchanger inlet

Connection on heat exchanger inlet

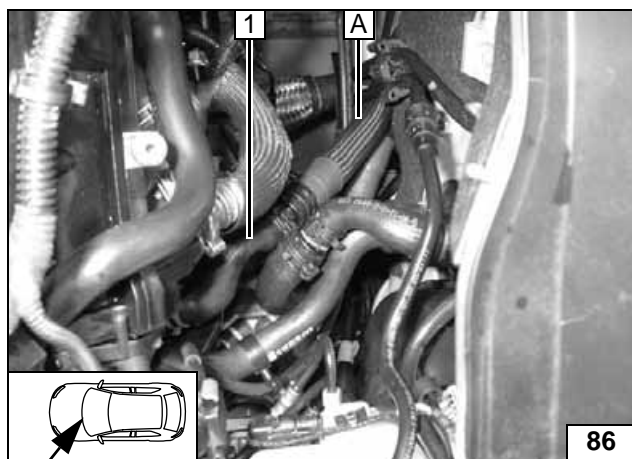

Before connecting, fill the water hoses with coolant.

- (1) Hose on engine outlet



Connection to engine outlet

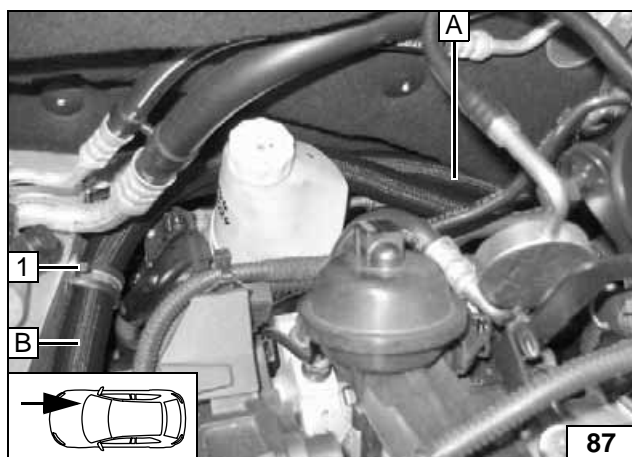

Align hose A, B and C over entire length and fix in place with cable ties.

1.7 liter diesel

Route coolant hose to cutting point.

- (1) Original vehicle stud bolt, rubber-coated p-clamp, 29 mm dia. plastic nut



Routing in engine compartment

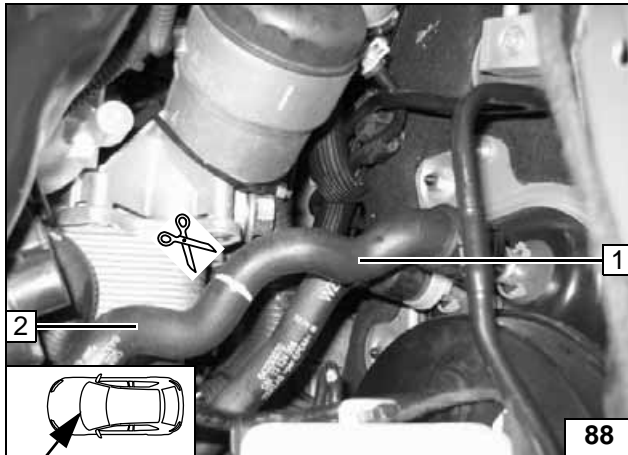

- (1) Hose section on heat exchanger inlet
- (2) Hose section on engine outlet

Cutting point

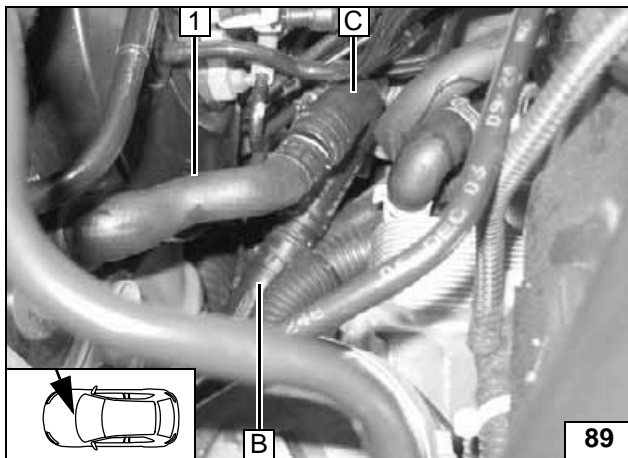

- (1) Hose on heat exchanger inlet

Connection on heat exchanger inlet

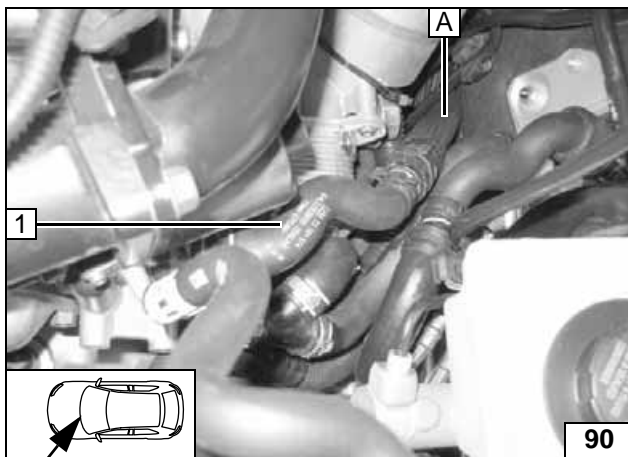

Before connecting, fill the water hoses with coolant.



- (1) Hose on engine outlet

Connection to engine outlet

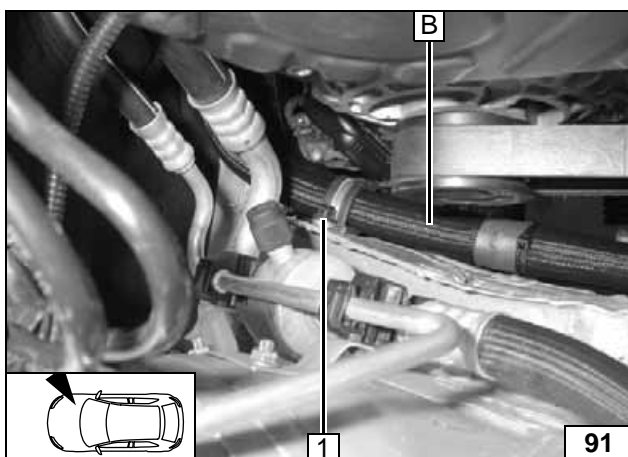

Align hose A, B and C over entire length and fix in place with cable ties.



1.9 liter diesel



Route coolant hose to cutting point.

- (1) Original vehicle stud bolt, rubber-coated p-clamp, plastic nut

Routing in engine compartment

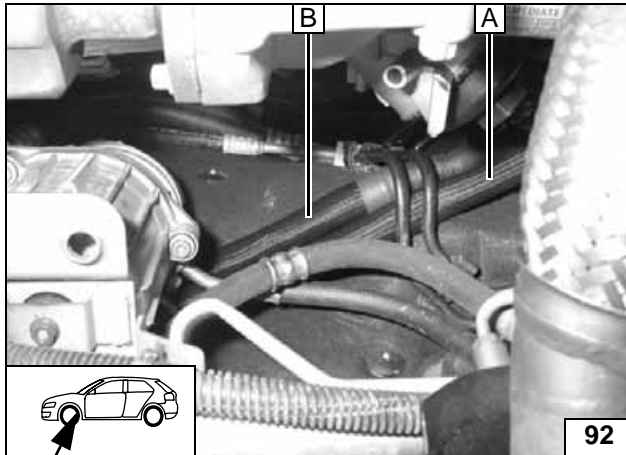

Routing in engine compartment

(1) Engine outlet hose to heat exchanger inlet

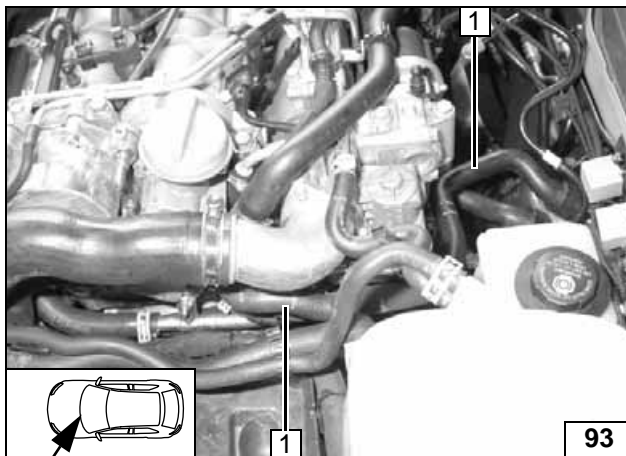

Removing hose

Protective hose removed before cutting!

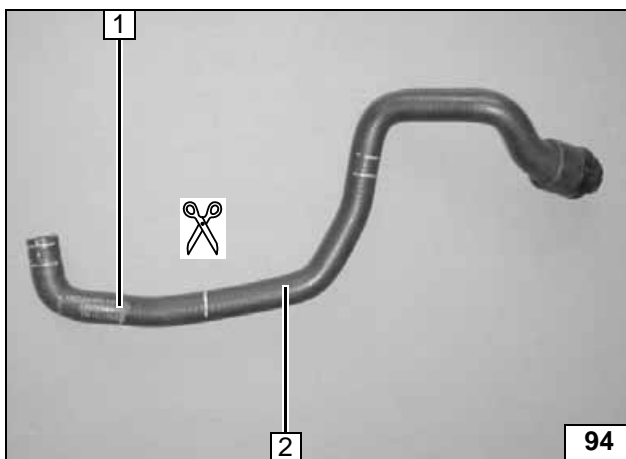

(1) Hose section on engine outlet
(2) Hose section on heat exchanger inlet



Cutting point

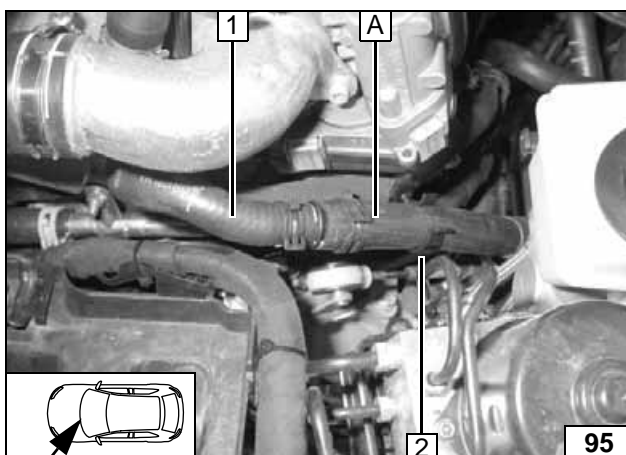

(1) Hose on engine outlet
(2) Spacer bracket

Connection to engine outlet

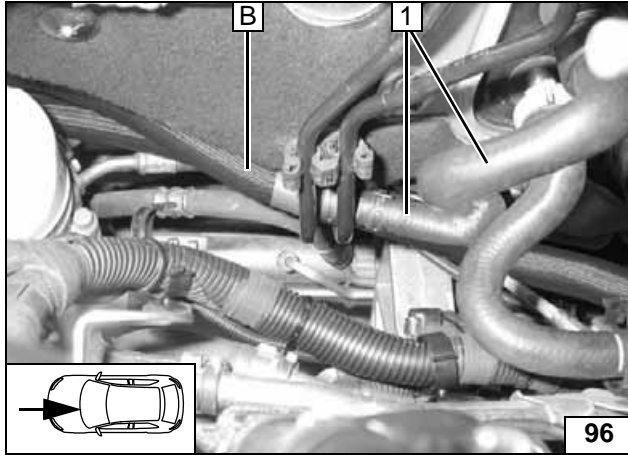

Before connecting, fill the water hoses with coolant.
Align hose section from heat exchanger inlet (1) to right when installing.

(1) Hose on heat exchanger inlet



Conne-
ction on
heat ex-
changer
inlet

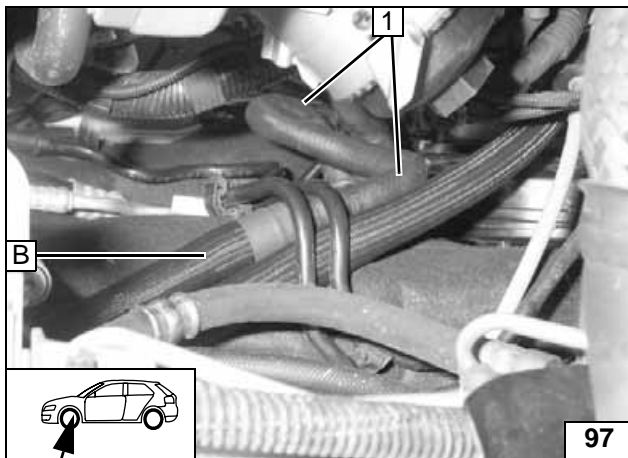

View from below!

(1) Hose on heat exchanger inlet



Conne-
ction to
heat ex-
changer
inlet

Align hoses **A** and **B** over entire length and fix in place with cable ties.



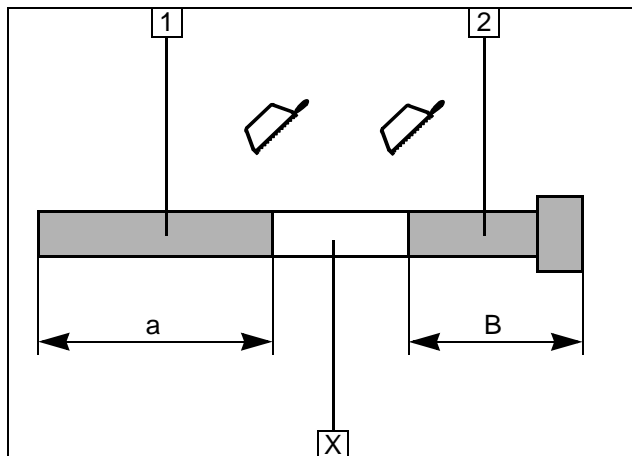
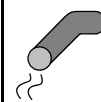

Exhaust system

- (1) Exhaust pipe
a = 200 mm
- (2) Exhaust end section
b = 100 mm

Discard section X

Preparing exhaust pipe

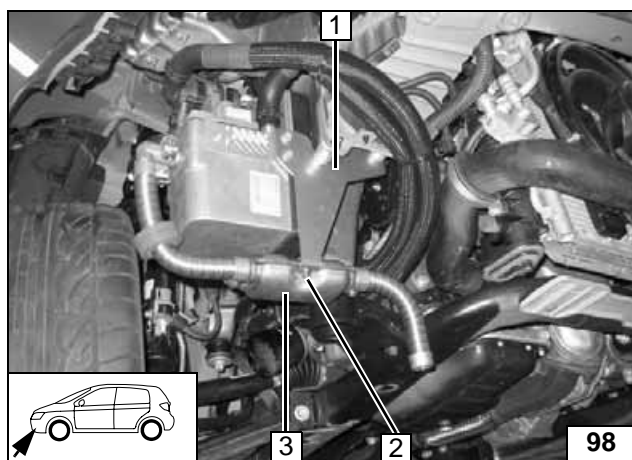

- 1 Bracket
- 2 M6x20 bolt, flanged nut
- 3 Muffler

Installing muffler

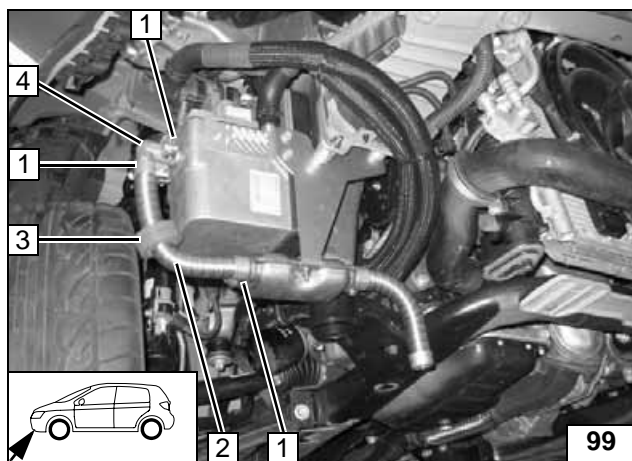

- 4 Exhaust elbow
- 2 Exhaust pipe
- 3 Red (rt) rubber isolator
- 1 Hose clamp [3x]

Installing exhaust pipe

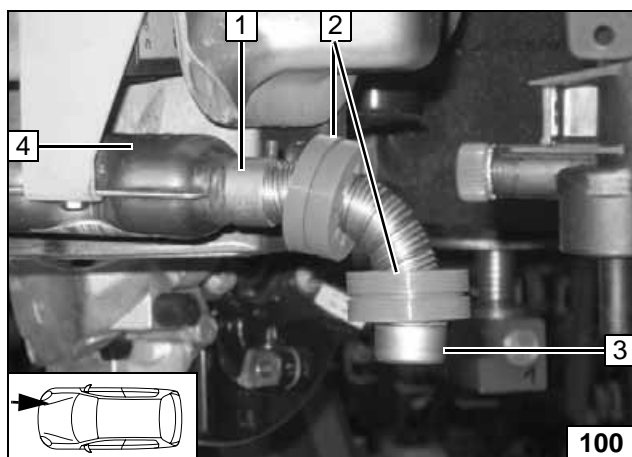

- 4 Exhaust muffer
- 3 Exhaust end section
- 1 Hose clamp
- 2 Position red (rt) rubber isolator [2x]

Installing exhaust pipe and end section

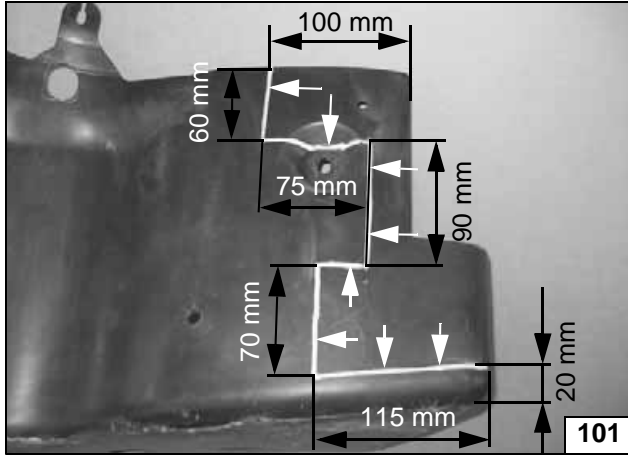
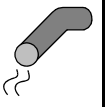

Gasoline

Design of underride protection/wheel well trim is dependent on vehicle equipment

Cut out underride protection/wheel well trim on marking.



Underride protection /wheel well trim

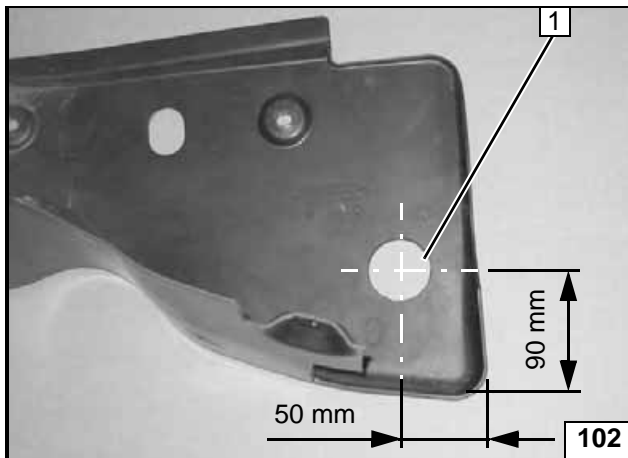

(1) 42 mm dia. hole

Underride protection /wheel well trim

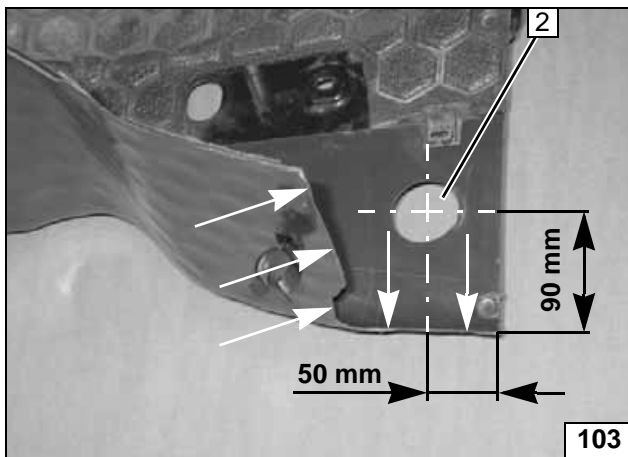

Diesel

Design of underride protection/wheel well trim is dependent on vehicle equipment

Cut out underride protection/wheel well trim on marking.

(1) 42 mm dia. hole



Underride protection /wheel well trim

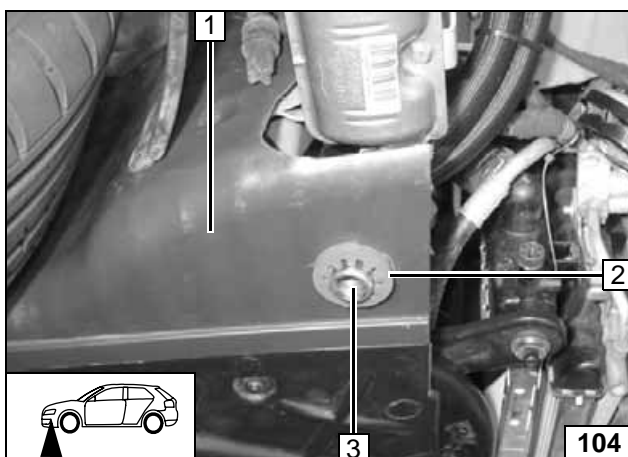

All vehicles

Check the position of the components; adjust if necessary. Check that they have free clearance.

- (1) Underride protection/wheel well trim
- (2) Red (rt) rubber isolator positioned with groove in trim
- (3) Exhaust end section



Underride protection /wheel well trim

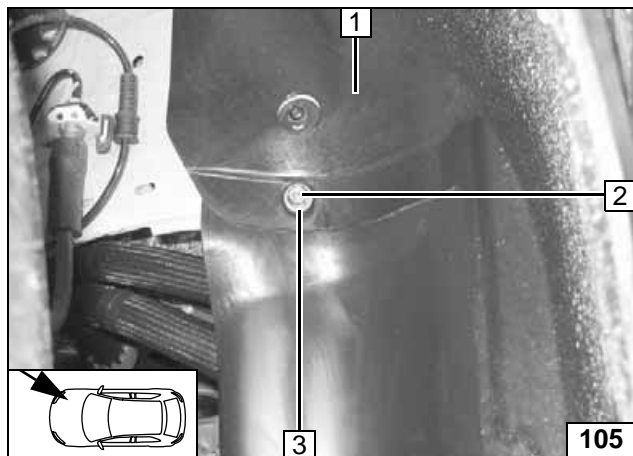
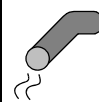

- (1) Wheel well trim
- (2) Premounted bolt from fastening of coolant hoses
- (3) Flanged nut and 22 mm dia. large diameter washer

Wheel well trim

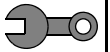

Final Work

WARNING!

Reassemble the disassembled components in reverse order.

Check all hoses, hose, spring and Caillau clamps, as well as all electrical connections for firm seating.

Secure all loose cables using cable ties.

Only use manufacturer-approved coolant.

Spray the heater unit components with anti-corrosion wax (Tectyl 100K, Order No. 111329).

- Connect the battery
- Fill and bleed the coolant circuit according to the vehicle manufacturer's specifications.
- Set the digital timer.
- Make settings on A/C control panel according to the "Operating Instructions for End Customer".
- Check the proper operation of the additional heater, see the operating instructions/installation instructions.
- Attach the "Switch off additional heater before refueling" sticker to the left-hand B-pillar.



Webasto
Feel the drive

Webasto AG
Postfach 80 - 82132 Stockdorf, Germany - Hotline +49-
(0)1805-932278

Operating Instructions for End Customer

Please remove page and add to the vehicle operating instructions.

On vehicles with passenger compartment monitoring, this is deactivated when operating the additional heater!

Before parking the vehicle, make the following settings:



- (1) Set air distribution to "Defrost"
- (2) Set temperature to "max."



- (1) Set air distribution to "Defrost"
- (2) Set temperature to "max."



Observe sequence of settings (see following illustration).

- (3) Set air distribution to above
- (1) Set temperature to "max."
- (2) Set fan to level "3"



Vehicles with "Heating and ventilation system"

Vehicles with "Automatic air conditioning" (SAC)



Vehicles with "Automatic air conditioning" (ECC)



Vehicles with "Automatic air conditioning" (ECC)

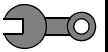

Template for Fuel Sender

The template is dependent on the respective vehicle equipment!

All vehicles
except Z17DTR/A17DTR and
Z17DTJ/A17DTJ:

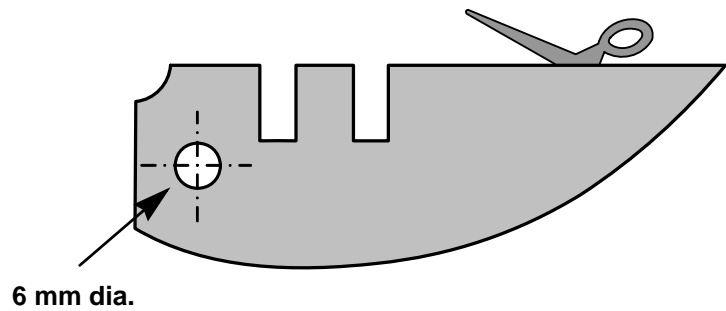

Z17DTR/A17DTR
and Z17DTJ/A17DTJ:

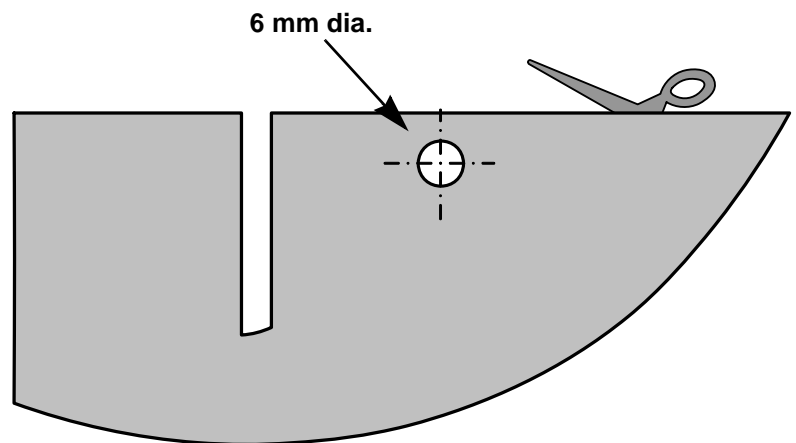

100 mm



Scale 1:1

Compare the size of the printed version with dimension lines.
Permitted tolerance a maximum of 2%.

Correct major differences in the printer settings or request an
original printout.

0

100 mm

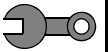

Template for Fuel Standpipe

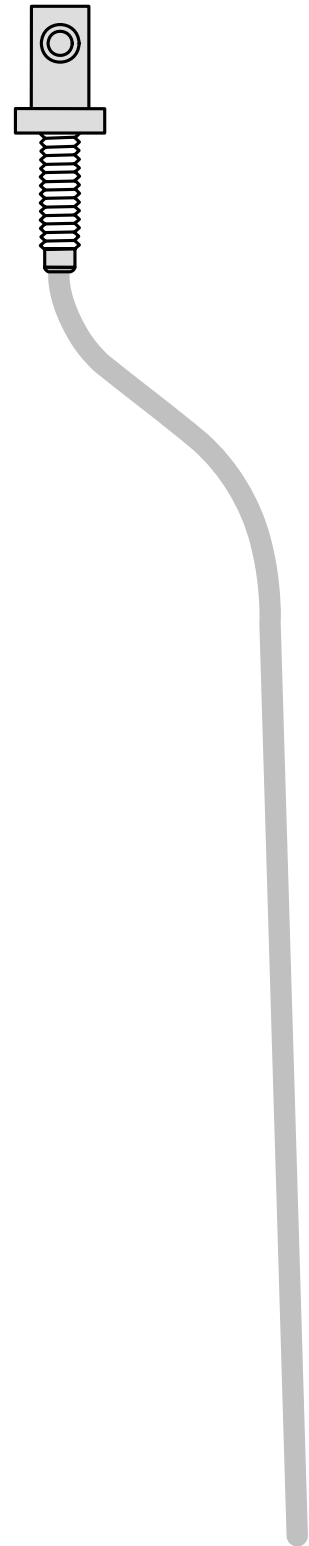

100 mm



Scale 1:1

Compare the size of the printed version with dimension lines.
Permitted tolerance a maximum of 2%.

Correct major differences in the printer settings or request an original printout.

100 mm

0

