

- (D)** Einbauanleitung / nur Händlereinbau
- (GB)** Installation instructions / Dealer installation only
- (F)** Consignes de montage / Montage uniquement par le concessionnaire
- (NL)** Montagehandleiding / Montage alleen door dealers
- (DK)** Montagevejledning / Montage kun hos forhandleren
- (N)** Monteringsinstruksjon / Montasje kun hos forhandleren
- (S)** Installationsanvisning / Får endast monteras av återförsäljaren
- (FIN)** Asennusohje / Asennus vain myyntiliikkeen toimesta
- (I)** Istruzioni per il montaggio / Installazione solo presso la concessionaria
- (E)** Instrucciones de montaje / Instalación exclusiva por el distribuidor
- (P)** Instruções de montagem / Montagem só no concessionário
- (GR)** Οδηγίες εγκατάστασης / Συναρμολόγηση μόνο από έμπο ρους
- (CZ)** Návod k montáži / Montá pouze prodejcem
- (PL)** Instrukcja montażu / Montaż tylko u dealera
- (TR)** Montaj talimatı / Sadece satıcı tarafında monte edilir
- (H)** Beépítési útmutató / Csak a kereskedő építheti be
- (HR)** Upute o ugradnji / Ugradnja samo od strane trgovca
- (BUL)** Инструкция за монтаж / Монтажът може да се извърши само от търговеца
- (RO)** Instrucțiuni de montaj / Se va monta numai de către dealer
- (RUS)** Инструкция по монтажу и установке / Устанавливать только у дилера
- (LT)** Montavimo informacija / Montuoja tik prekybininkas
- (LV)** Iemontēšanas pamācība / Tikai pārdevēja iebūve
- (EST)** Paigaldusjuhend / Paigaldab ainult müüja
- (SLO)** Navodilo za vgradnjo / Vgradnja le od trgovca
- (SK)** Montážny návod / Montá iba obchodníkom
- (J)** 取り付け説明書 / 販売業者取り付けのみ
- (ROK)** 장치 지시사항 / 오직 전문상인이 장치
- (THA)** คู่มือการติดตั้ง / ติดตั้งโดยตัวแทนจำหน่ายเท่านั้น
- (VR)** 安装说明书 / 仅供销售商安装用
- (VR)** 安裝說明書 / 僅供銷售商安裝用



- D** Beim Verbau der Anhängerzugvorrichtung ist darauf zu achten, dass alle benötigten Abgassystem Hitzeschutzschilde, abhängig nach Motorvariante, nachgerüstet werden. Details zu Hitzeschutzschild siehe EPC.
- GB** When fitting the trailer towing device it has to be ensured that the entire exhaust system and relevant heat protection shields required, depending on engine variation, are retrofitted. For details on the heat protection shields see EPC.
- F** Lors du montage du dispositif de traction de remorque, veiller impérativement à ce que tous les systèmes de gaz d'échappement et boucliers anti-chaleur afférents au moteur soient ajoutés. Pour plus de détails concernant les boucliers anti-chaleur, voir EPC.
- NL** Bij de montage van de trekvoorziening voor de aanhanger erop letten dat alle nodige hitteschilden voor het uitlaatgas-systeem in afhankelijkheid van de motorvariant worden aangebracht resp. aangepast. Zie voor de details voor het hitteschild EPC.
- DK** Ved montering af anhængertrækanordningen skal man være opmærksom på, at alle nødvendige varmeskjold til udstødningssystemet, afhængig af motortype, bliver eftermonteret. Detaljer til varmeskjold, se EPC.
- N** Ved montasje av trekkanordningen for tilhengereskal legges merke på, at alle nødvendige varmeskjold av avgass-systemet suppleres, hver etter motortype. Detaljer om varmeskjold se EPC.
- S** När dragningsanordningen för släpet monteras, ge akt på att upprusta alla värmeskyddssköldar som behövs för avgass-systemet och som beror på motorvarianten. För detaljer angående värmeskyddsskölden, se EPC.
- FIN** Perävaunun suojalaitteen rakenne on varmistuttava, että kaikki moottorivaihtoehdon mukaan laaditut pakokaasujärjestelmän kuumuudelta varoittavat taulut on asennettu takaisin. Kuumuudelta varoittavien taulujen yksityiskohdat löytyvät EPC:stä.
- I** Nel montaggio del dispositivo di trazione del traino ci si assicuri, che tutti i carter di protezione dal calore dei gas di scarico vengano adeguati in base al tipo di motore. Per dettagli sul carter protettivo dal calore si veda l'EPC.
- E** Para la entibación del dispositivo de remolque se debe prestar atención a que todos los paneles de protección térmica necesarios del sistema de gases de escape sean adaptados dependiendo del modelo de motor. Detalles de paneles de protección térmica, véase EPC.
- P** Com a instalação do dispositivo de tracção do reboque, é preciso ter atenção a que sejam reinstaladas todas as placas de protecção térmica do sistema de emissão de gases, que sejam necessárias. Para detalhes sobre placa de protecção térmica, ver EPC.
- GR** Κατά τη συναρμολόγηση του μηχανισμού ρυμούλκησης πρέπει να δίδεται προσοχή, στο να είναι όλα τα απαιτούμενα σκεπάσματα θερμικής προστασίας του συστήματος εξαγωγής αέρα εξοπλισμένα εκ των υστέρων, ανάλογα με τον τύπο του κινητήρα. Για λεπτομέρειες περί του σκεπάσματος θερμικής προστασίας βλέπε EPC.
- CZ** Při montáži tažného zařízení přívěsu je třeba dbát na to, aby bylo dovybaveno veškerými potřebnými tepelnými ochrannými štíty systému spalných plynů - závislí na variantě motoru. Detaily k tepelnému ochrannému štítu viz EPC.
- PL** Podczas zabudowy haka holowniczego należy zwrócić uwagę, żeby nastąpiło dodatkowo wyposażenie we wszystkie niezbędne tabliczki ostrzegawcze przed gorącym systemem wydechowym, zależnie od odmiany silnika. Szczegóły dotyczące tabliczki ostrzegawczej patrz EPC.
- TR** Bir römork çekme tertibatı monte edilirken, ihtiyaç duyulan tüm egzoz sistemi ısıya karşı koruma yalıtımlarının donatılmış olmasına dikkat edilmelidir. Isıya karşı koruma yalıtımı ile ilgili detaylar için EPC'ye bakınız.
- H** Az utánfutó vontató berendezés átszerelésekor arra kel vigyázni, hogy az összes szükséges kipufogórendszer hővédő táblákat, a motor fajtájától függően, utána kell állítani. A hővédő tábláról a részleteket lásd az EPC -n.
- HR** Kod zagrađivanja karniže potrebno je obratiti pozornost na to da svi nužni sustavi ispušnih plinova budu pojačani zaštitom protiv vrućine, ovisno o varijanti motora. Detalje o zaštiti protiv vrućine vidi EPC.
- BUL** При монтажа на теглича на ремаркетото трябва да се внимава всички изолационни детайли, необходими за защита на системата за отработени газове от нагорещяване да бъдат окомплектовани според варианта на двигателя. За подробности относно изолационните детайли за защита от нагорещяване виж EPC.
- RO** Pentru sustinerea provizorie a dispozitivului de remorcare se va urmări ca sistemul de evacuaire a gazelor să fie prevăzut cu indicatoare de protecție la ardere, dependent de varianta motorului. Detalii referitoare la indicatoarele de protecție, la ardere, vezi în EPC.
- RUS** При креплении тягово-сцепного устройства необходимо следить за тем, чтобы была произведена доукомплектация выхлопной системы всеми необходимыми теплозащитными щитками, в зависимости от модификации двигателя. Более детальную информацию о теплозащитных щитках Вы найдете в EPC.
- LT** Paremiant priekabos tempimo itaisa reikia stebėti, kad būtų atnaujintos visos dėl variklio išmetamųjų dujų aukštos temperatūros perspėjančios etiketės. Apie dėl aukštos temperatūros perspėjančias etiketes skaitykite detalių kataloge EPC.
- LV** Piekabes vilcēj mehānismu atbalstot ir jāseko, lai tiktu atjaunoti visi no motora varianta atkarojošies izplūdes gāzu augstas temperatūras brīdinājuma uzraksti. Par augstas temperatūras brīdinājuma uzrakstiem skati detaļas EPC.
- EST** Haagise veoseadme toestust tuleb jälgida, et kõik mootori variandist olenevad heitgaasisüsteemi kõrge temperatuuri hoiatussildid taastatakse. Kõrge temperatuuri hoiatussiltide kohta vt. detaile EPC-st.
- SLO** Pri preureditvi vlečne naprave za priklopnik morate paziti, da bodo vsi potrebni toplotni ščitniki za sistemi izpušnih nameščeni v odvisnosti od različice motorja. Podrobnosti o toplotnih ščitnikih glejte EPC.
- SK** Pri montáži t'ážného zariadenia prívěsu dbajte na to, aby boli všetky potrebné tepelné ochranné štíty výfukového systému, ktoré sú závislé od variantu motora, dodatočne vybavené. Detaily k tepelnému ochrannému štítu vid' EPC.



→ Check NEW UPDATES → [www.ifz-berlin.de](http://www.ifz-berlin.de)



**B-K**  
**Astra-K Sportstourer**  
**Astra-K Sportstourer +**

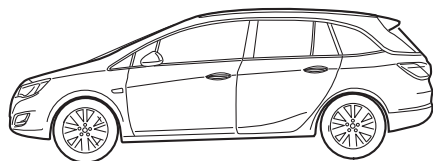

**1** **13 427 486**

**1**

XX XXX XXX

6x M10x30

6x M10

12x

M6

M6x28

APPROVAL NO **E13** 55R-01 3989

TYPE 314 490 D-VALUE D 9,9 kN

CLASS A50-X MAX. VERT. LOAD S 75 kg

PN 13427486 CHARGE

**westfalia**

**2**

8 / 10 / 13 mm

TORX 25/40

17 mm

10mm  
17mm

MKM-923

Ø 38

90485251

**Compound glueing seal**

**3**

**Service**

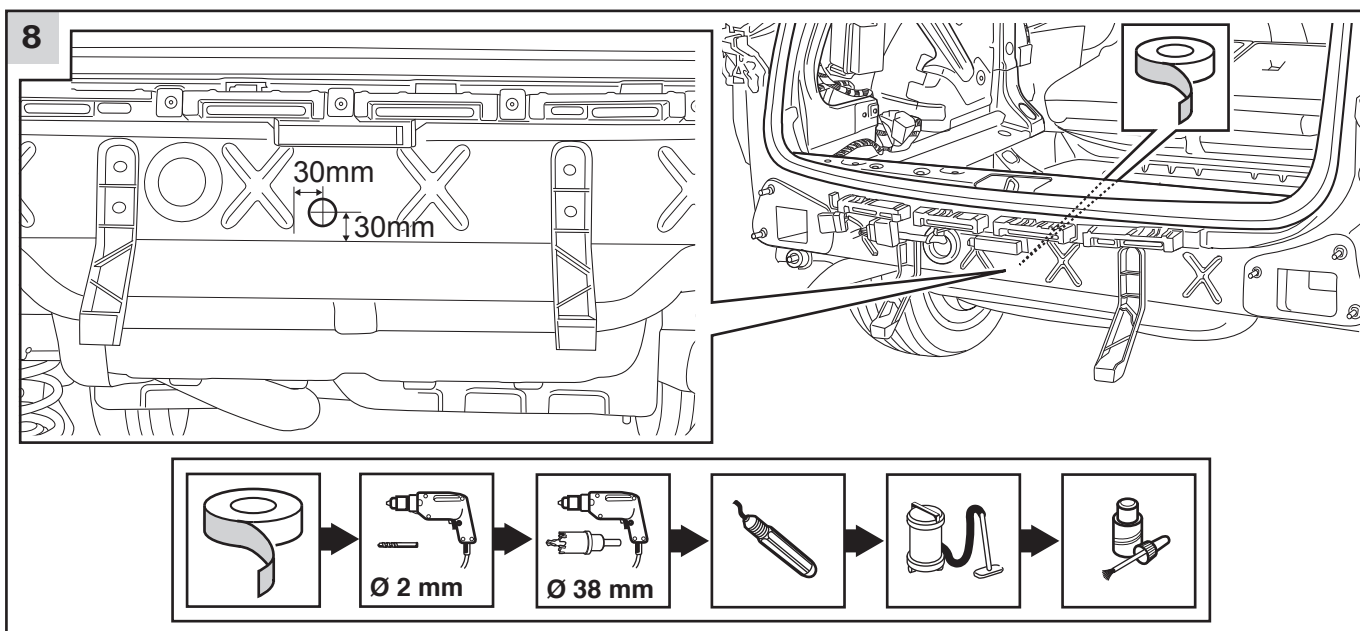
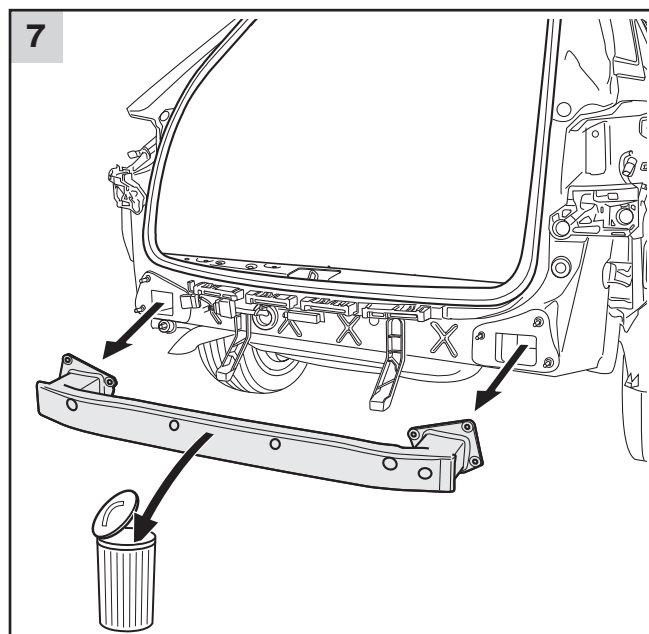
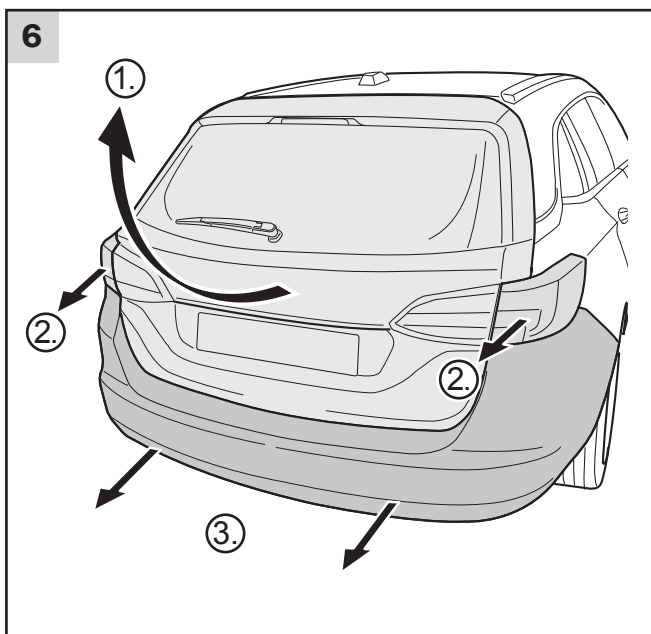
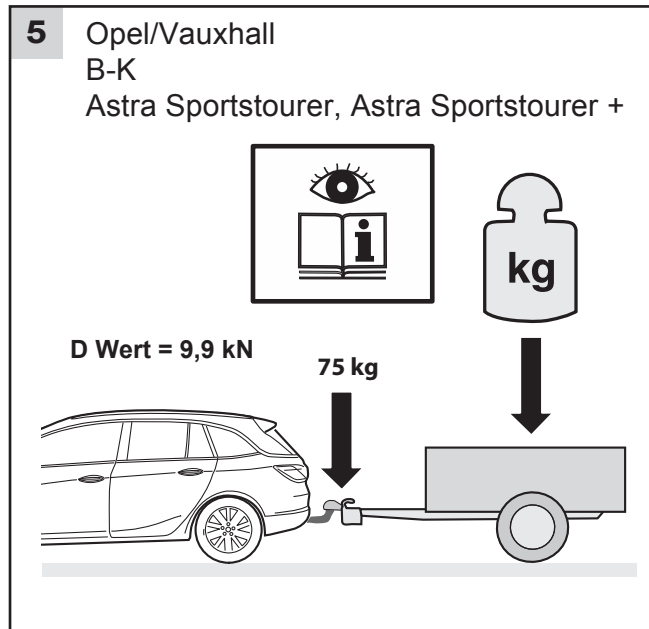
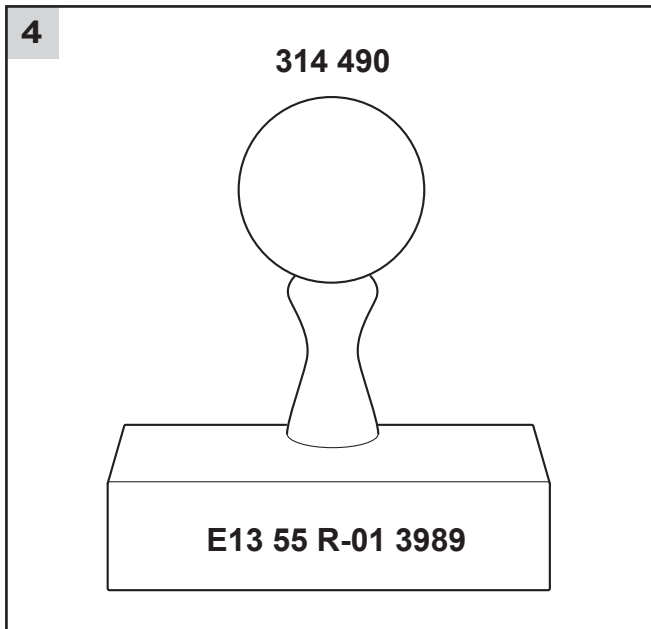

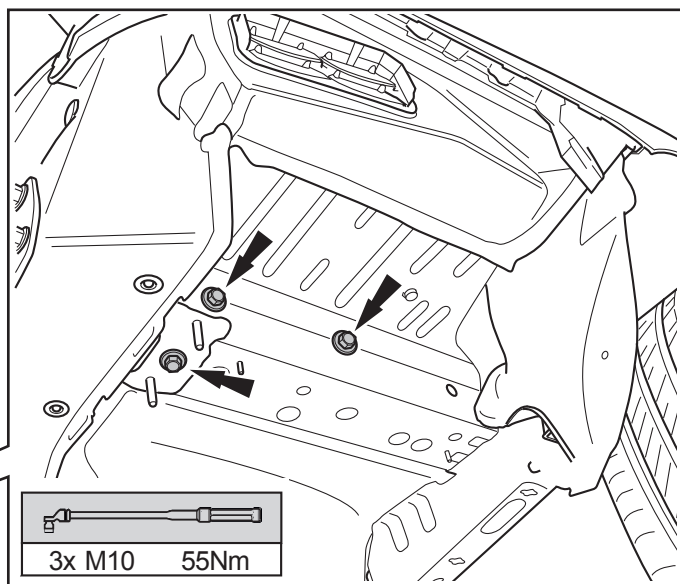
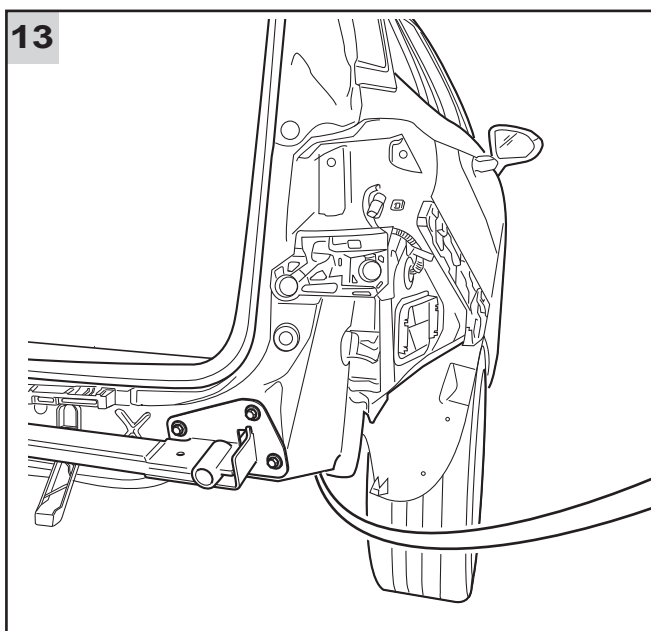
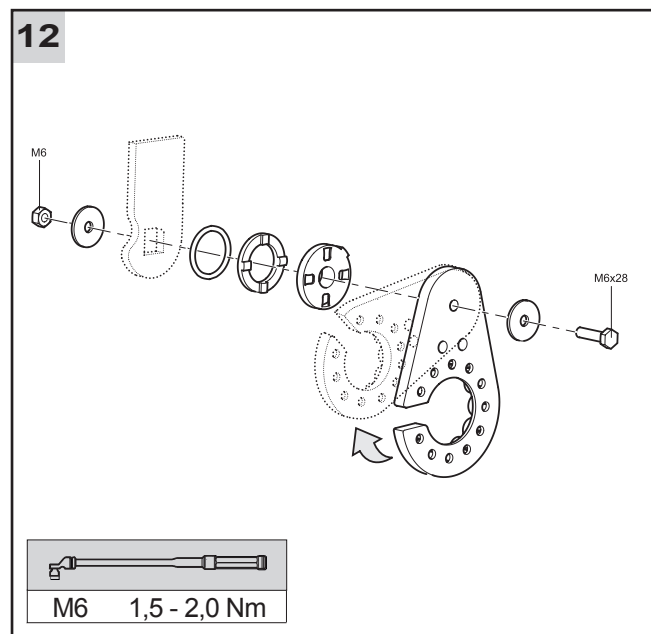
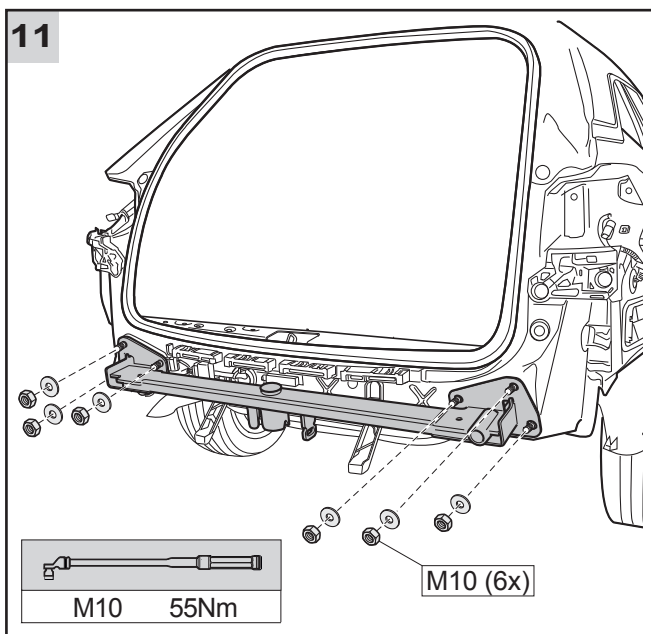
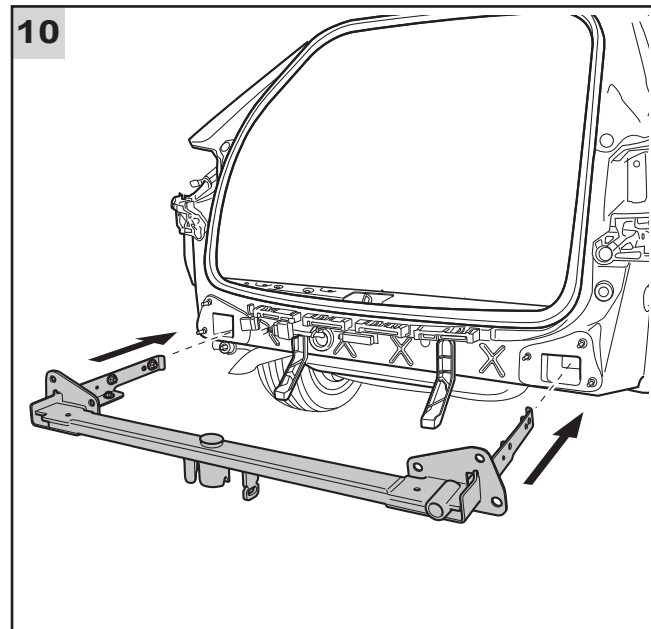
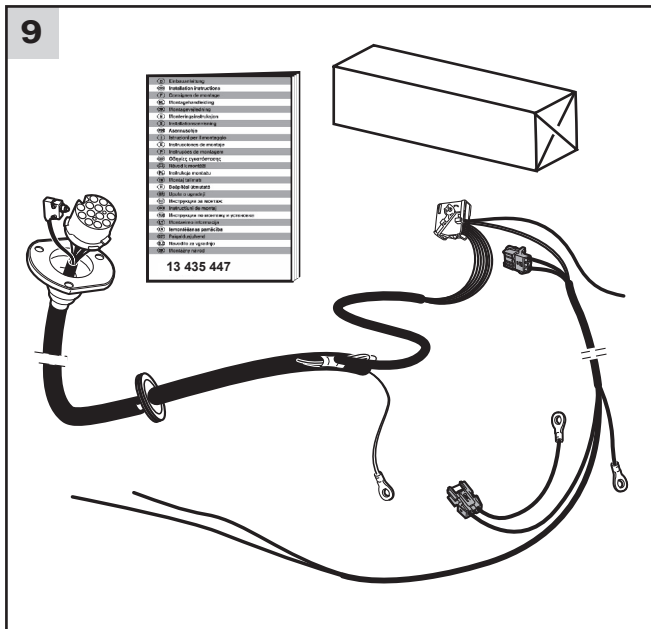

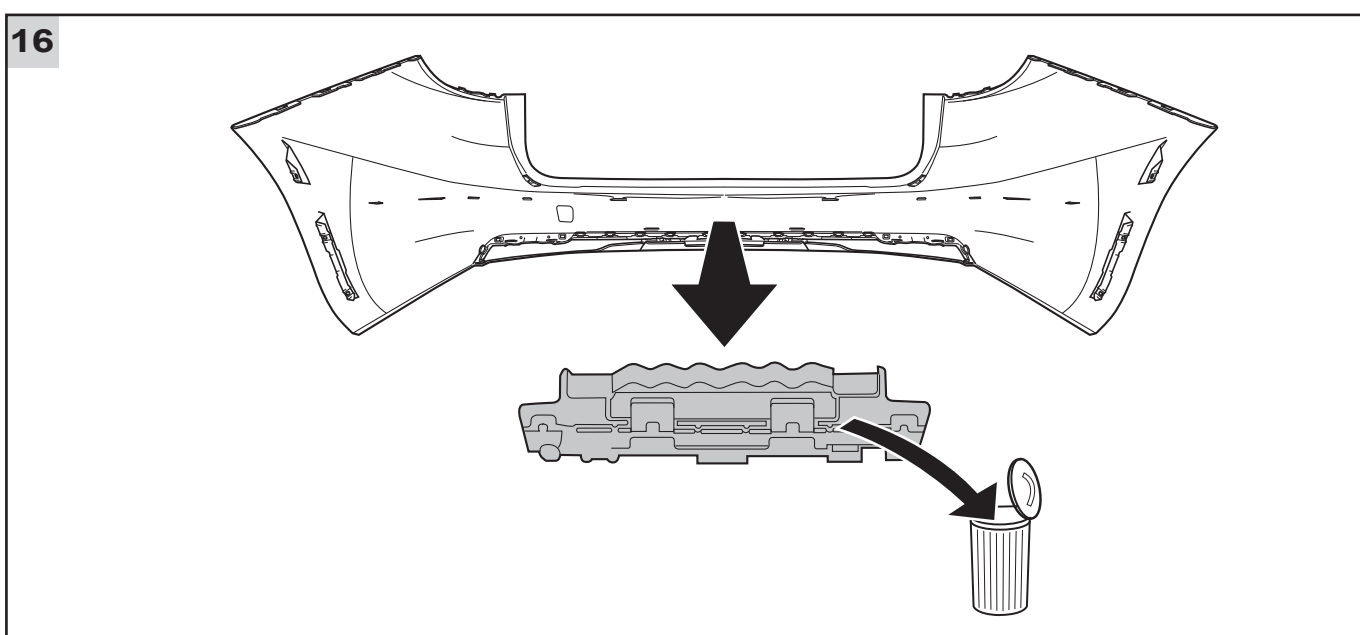
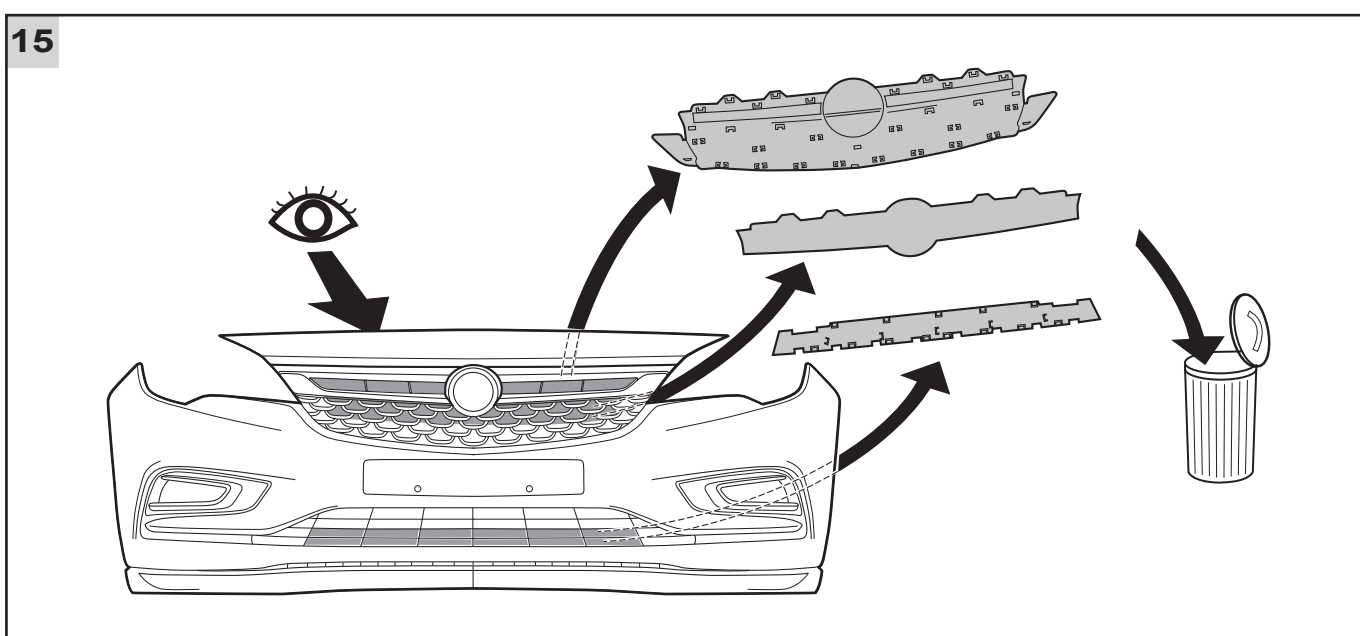
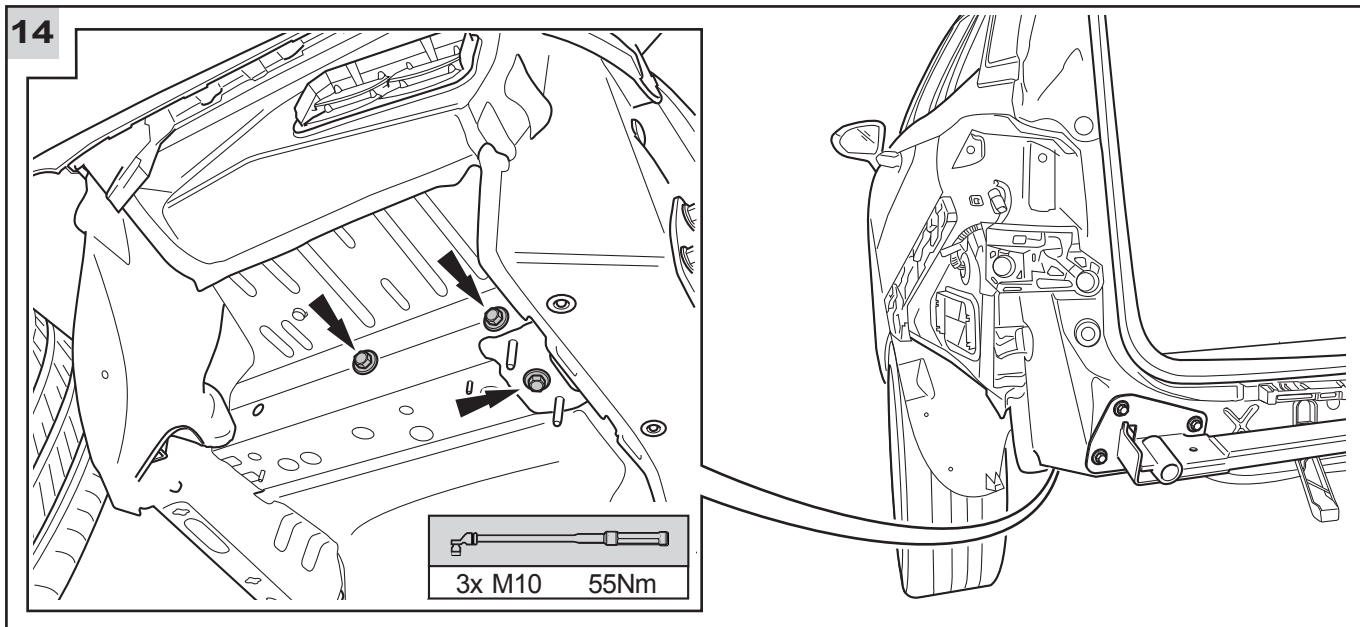

17

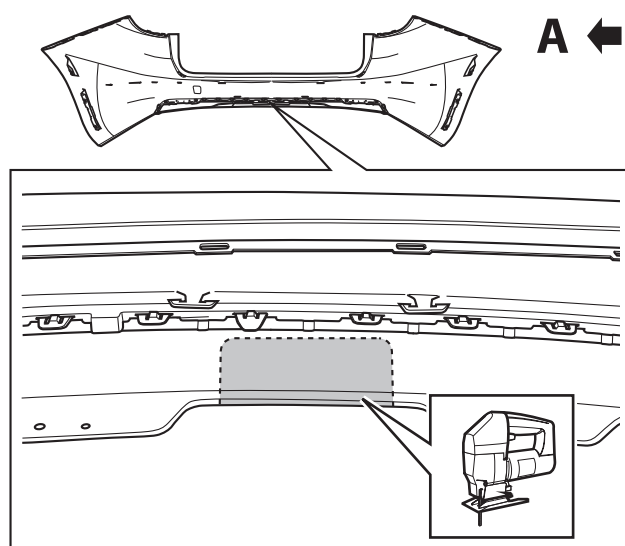

A ← OR → B



13 490 201



13 490 202



13 490 203



13 453 984



18

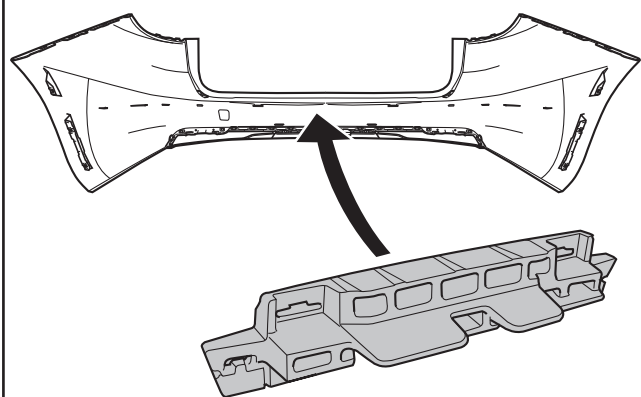

19

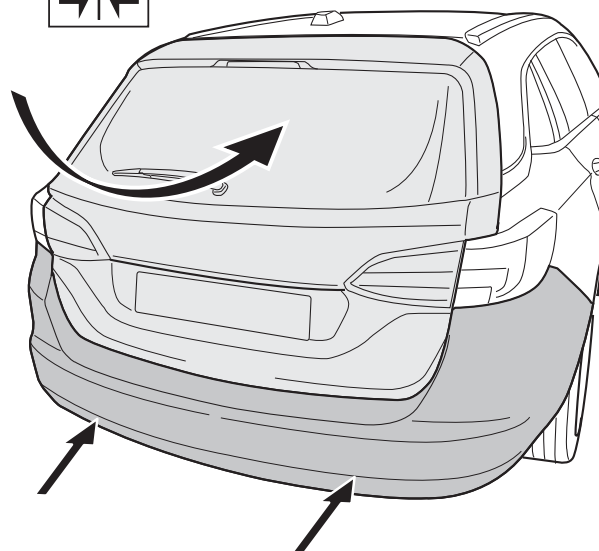

20



M10 55Nm



Service



1000 km



21

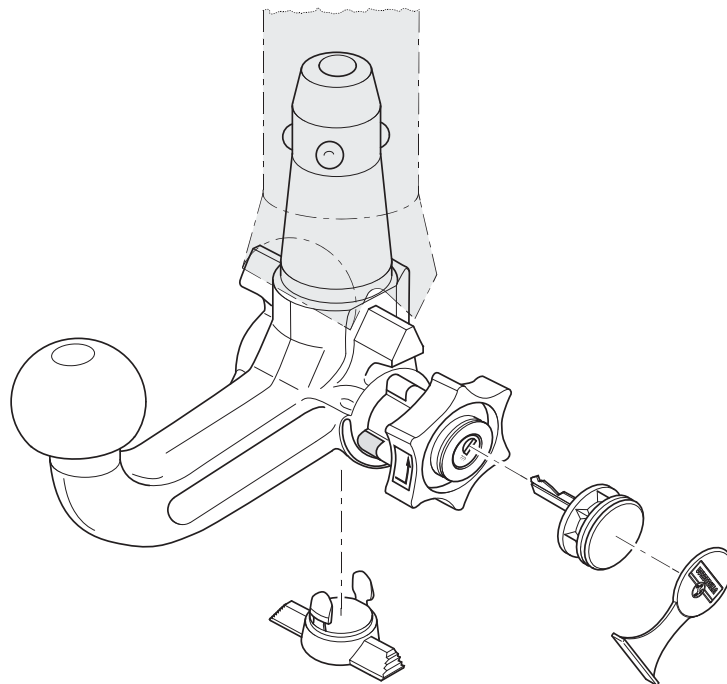

22

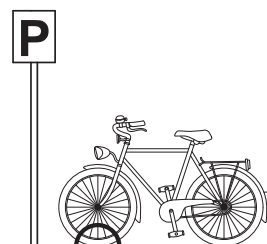
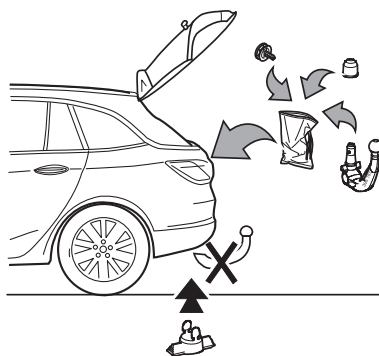
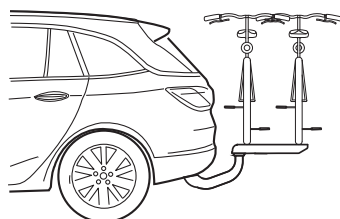
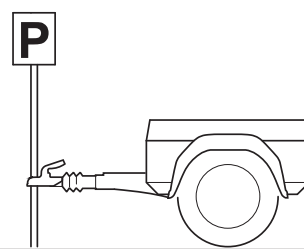
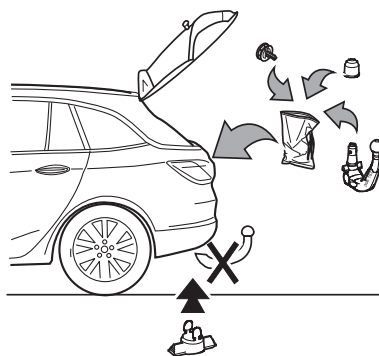
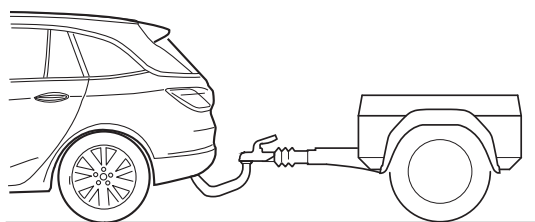
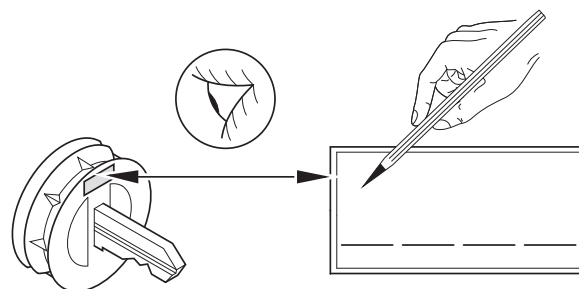



23

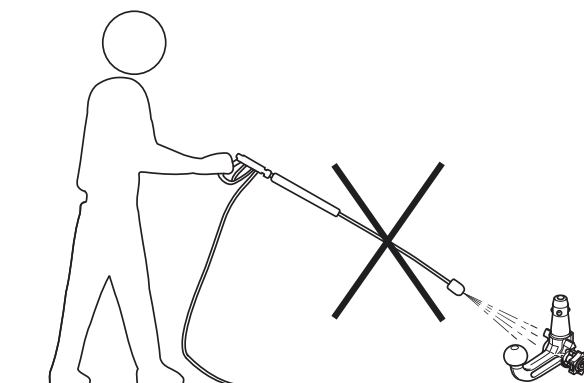
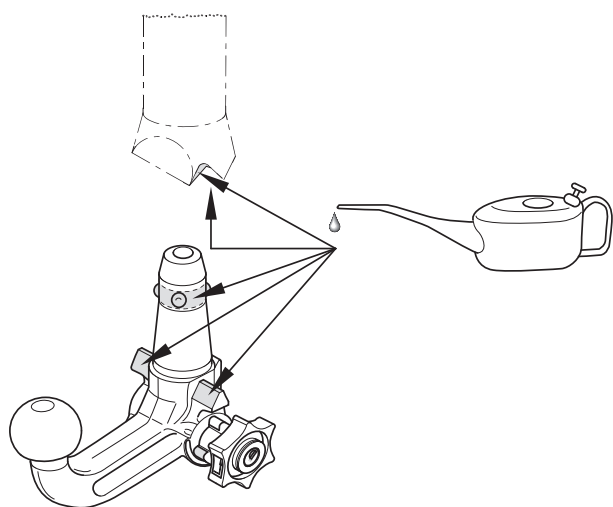
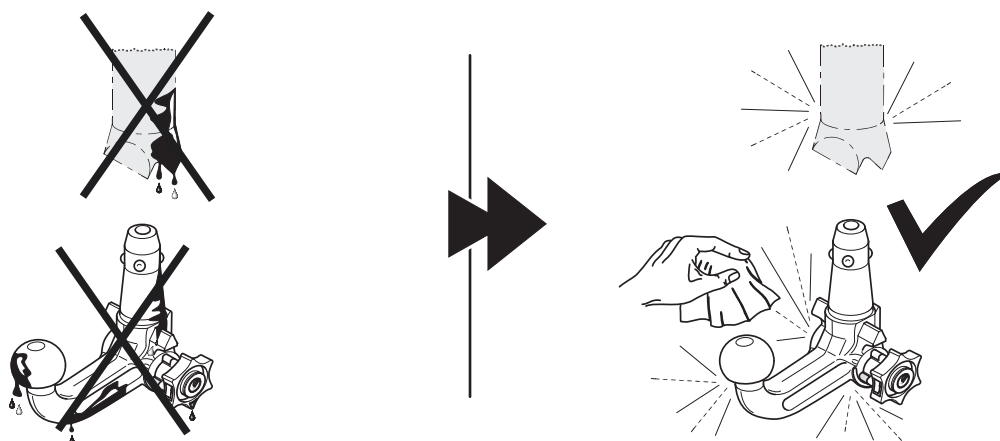
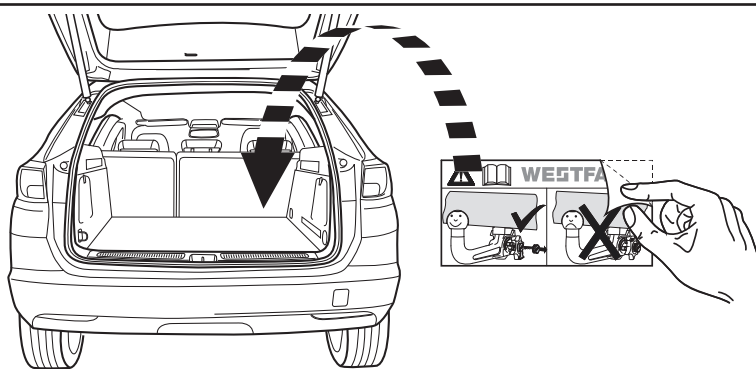
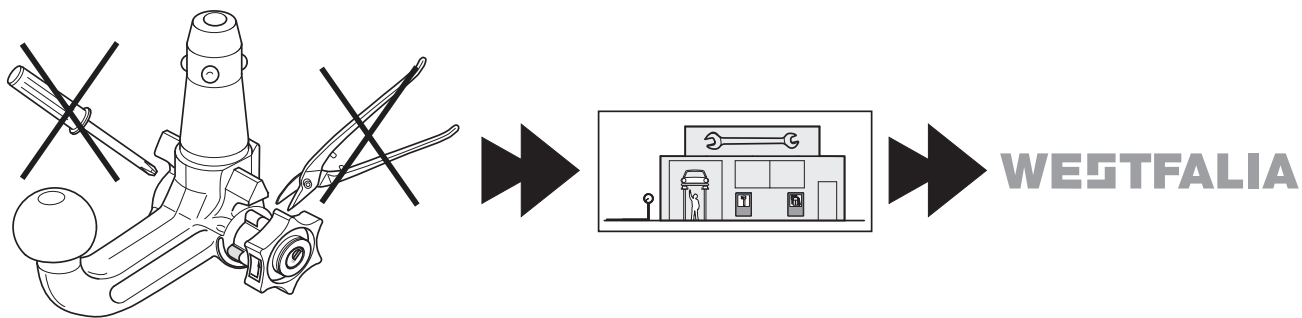

24

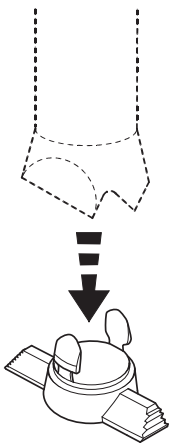

25

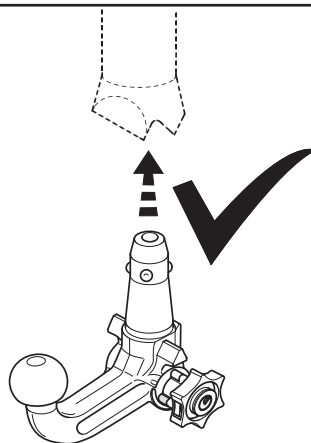
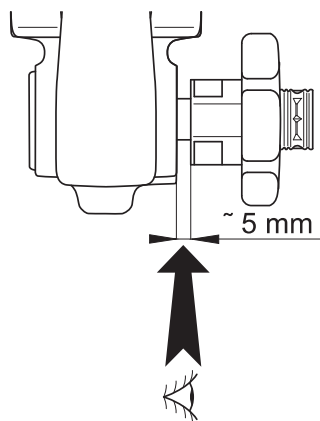

28

26

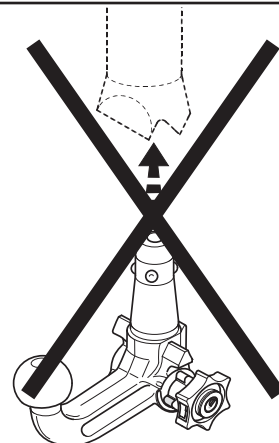
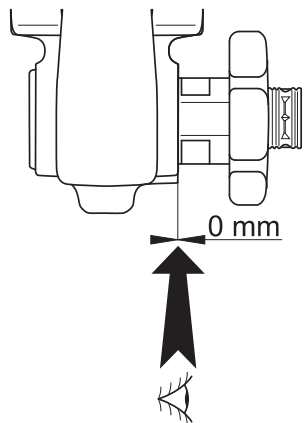

27

27

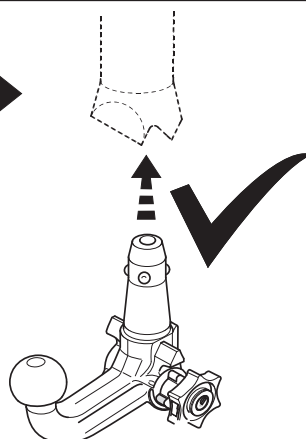
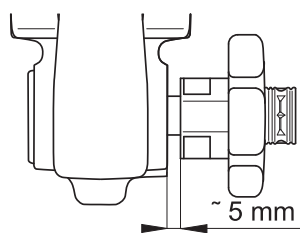
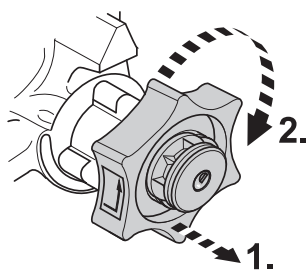

28

28

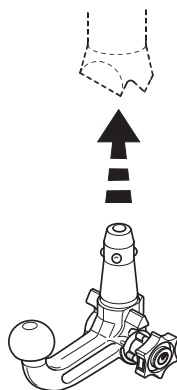

29

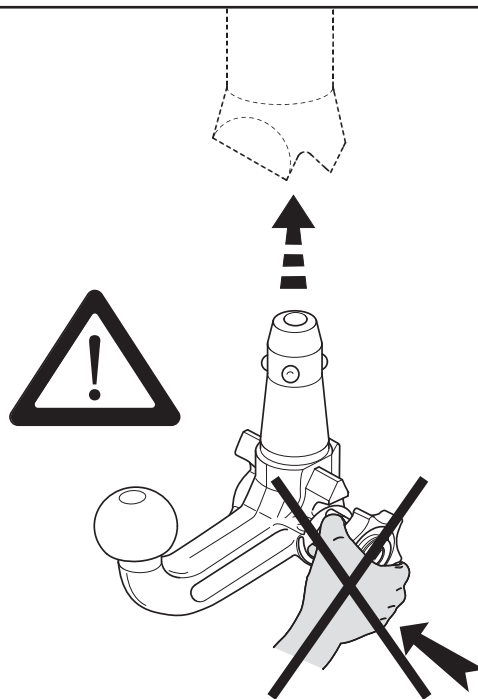
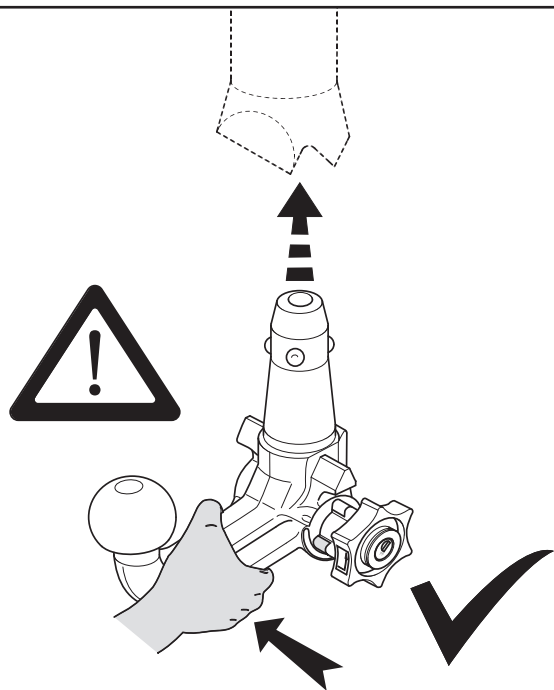

30

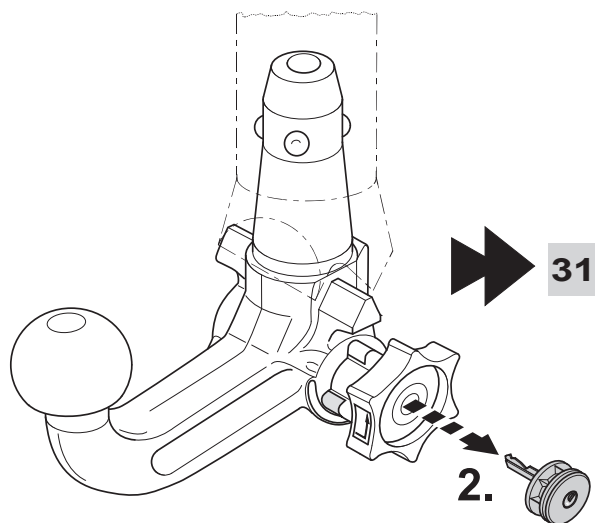
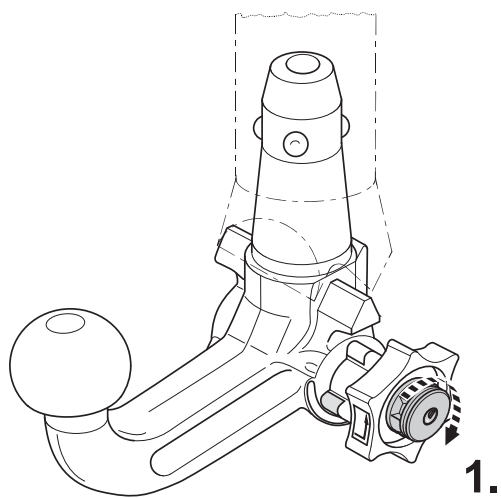

31

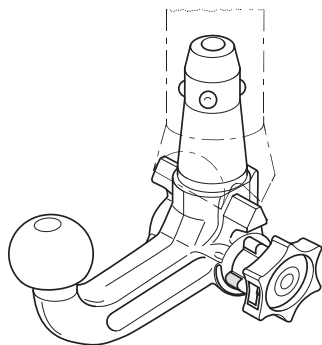

32

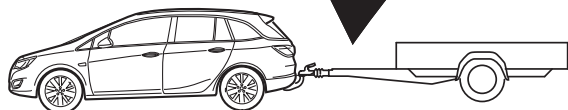
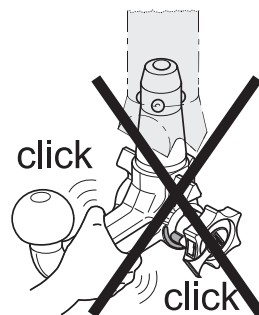
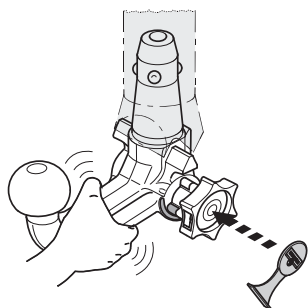
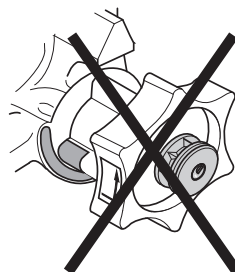
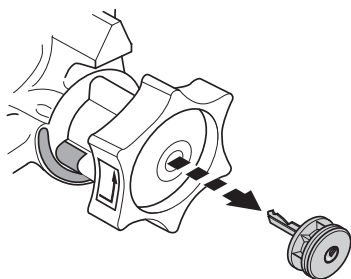
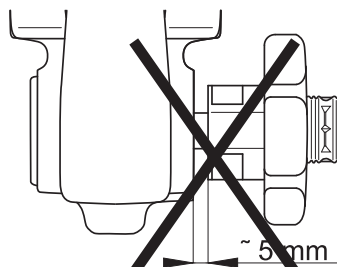
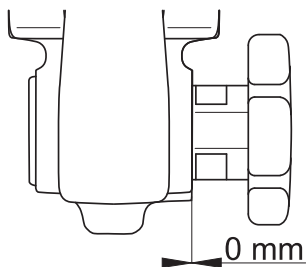
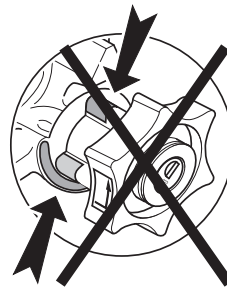
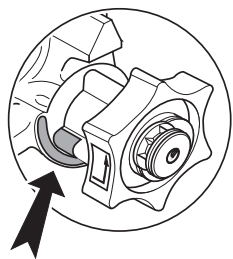

**33**

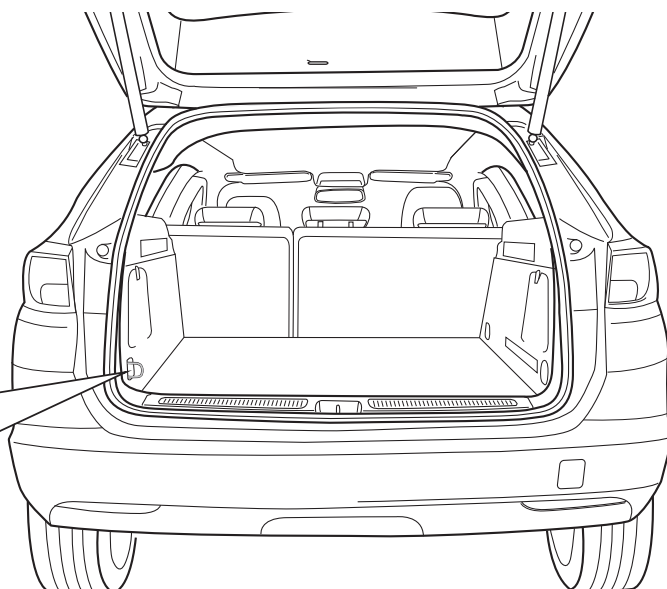
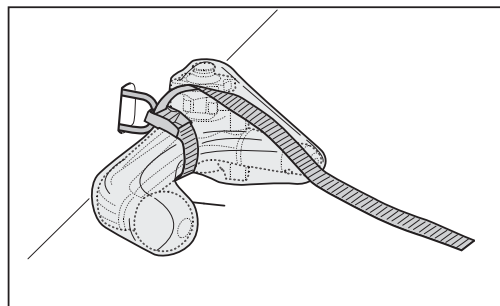

**34**

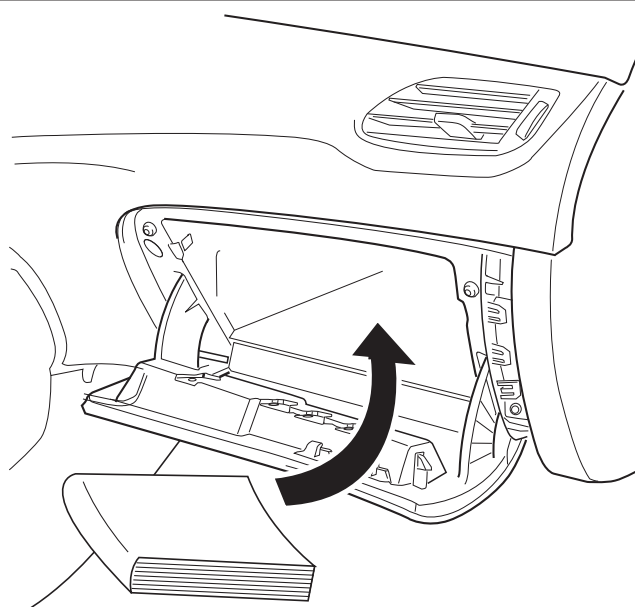

Dispositivo di traino tipo: **314 490**  
Per autoveicolo: **Astra Sportstourer / Astra Sportstourer +**  
Tipo funzionale: **B-K**

Classe e tipo di attacco: **A50-X**  
Omologazione: **E13 55 R-01 3989**  
Valore D: **9,9 kN**  
Carico verticale max. S: **75 kg**  
Massa rimorchiabile: vedi carta di circolazione dell'autoveicolo

In base alla Direttiva europea ECE-R 55, la massa massima rimorchiabile del dispositivo di traino è determinata dal valore di prova "D" così definitivo:

$$D = (T \times C) / (T + C) \times 0,00981 = \dots \text{kN}$$

dove:

T = Massa complessiva max. della motrice (in kg)

e C = Massa rimorchiabile max. della motrice (in kg)

#### DICHIARAZIONE DI CORRETTO MONTAGGIO:

la sottoscritta Ditta dichiara che il dispositivo di traino tipo .....  
è stato installato a regola d'arte, nel rispetto dei punti d'attacco e delle prescrizioni fornite dalla  
Casa costruttrice

sul veicolo .....

targato .....

..... li .....

timbro e firma

.....

Si dichiara inoltre di aver informato l'utente del veicolo sull'USO e MANUTENZIONE  
del dispositivo stesso.

- (D)** Einbauanleitung / nur Händlereinbau
- (GB)** Installation instructions / Dealer installation only
- (F)** Consignes de montage / Montage uniquement par le concessionnaire
- (NL)** Montagehandleiding / Montage alleen door dealers
- (DK)** Montagevejledning / Montage kun hos forhandleren
- (N)** Monteringsinstruksjon / Montasje kun hos forhandleren
- (S)** Installationsanvisning / Får endast monteras av återförsäljaren
- (FIN)** Asennusohje / Asennus vain myyntiliikkeen toimesta
- (I)** Istruzioni per il montaggio / Installazione solo presso la concessionaria
- (E)** Instrucciones de montaje / Instalación exclusiva por el distribuidor
- (P)** Instruções de montagem / Montagem só no concessionário
- (GR)** Οδηγίες εγκατάστασης / Συναρμολόγηση μόνο από εμπόρους
- (CZ)** Návod k montáži / Montáž pouze prodejcem
- (PL)** Instrukcja montażu / Montaż tylko u dealera
- (TR)** Montaj talimatı / Sadece satıcı tarafında monte edilir
- (H)** Beépítési útmutató / Csak a kereskedő építheti be
- (HR)** Upute o ugradnji / Ugradnja samo od strane trgovca
- (BUL)** Инструкция за монтаж / Монтажът може да се извърши само от търговеца
- (RO)** Instrucțiuni de montaj / Se va monta numai de către dealer
- (RUS)** Инструкция по монтажу и установке / Устанавливать только у дилера
- (LT)** Montavimo informacija / Montuoja tik prekybininkas
- (LV)** Iemontēšanas pamācība / Tikai pārdevēja iebūve
- (EST)** Paigaldusjuhend / Paigaldab ainult müüja
- (SLO)** Navodilo za vgradnjo / Vgradnja le od trgovca
- (SK)** Montážny návod / Montáž iba obchodníkom
- (J)** 取り付け説明書 / 販売業者取り付けのみ
- (ROK)** 장치 지시사항 / 오직 전문상인이 장치
- (THA)** คู่มือการติดตั้ง / ติดตั้งโดยตัวแทนจำหน่ายเท่านั้น
- (VR)** 安装说明书 / 仅供销售商安装用
- (VR)** 安裝說明書 / 僅供銷售商安裝用



→ Check NEW UPDATES → [www.ifz-berlin.de](http://www.ifz-berlin.de)



**Astra-K**

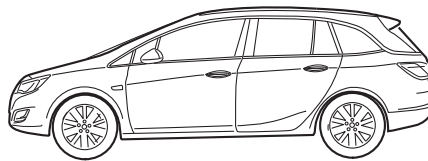
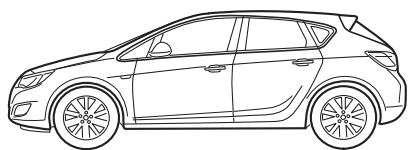

**1**

**13 440 297**

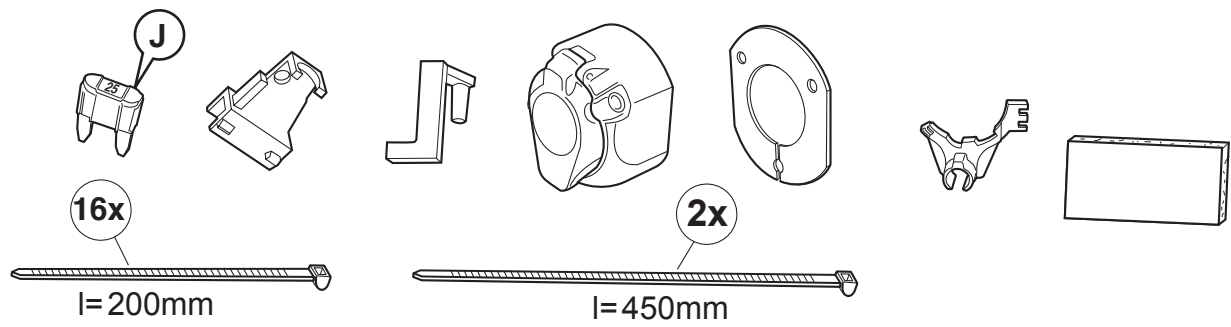
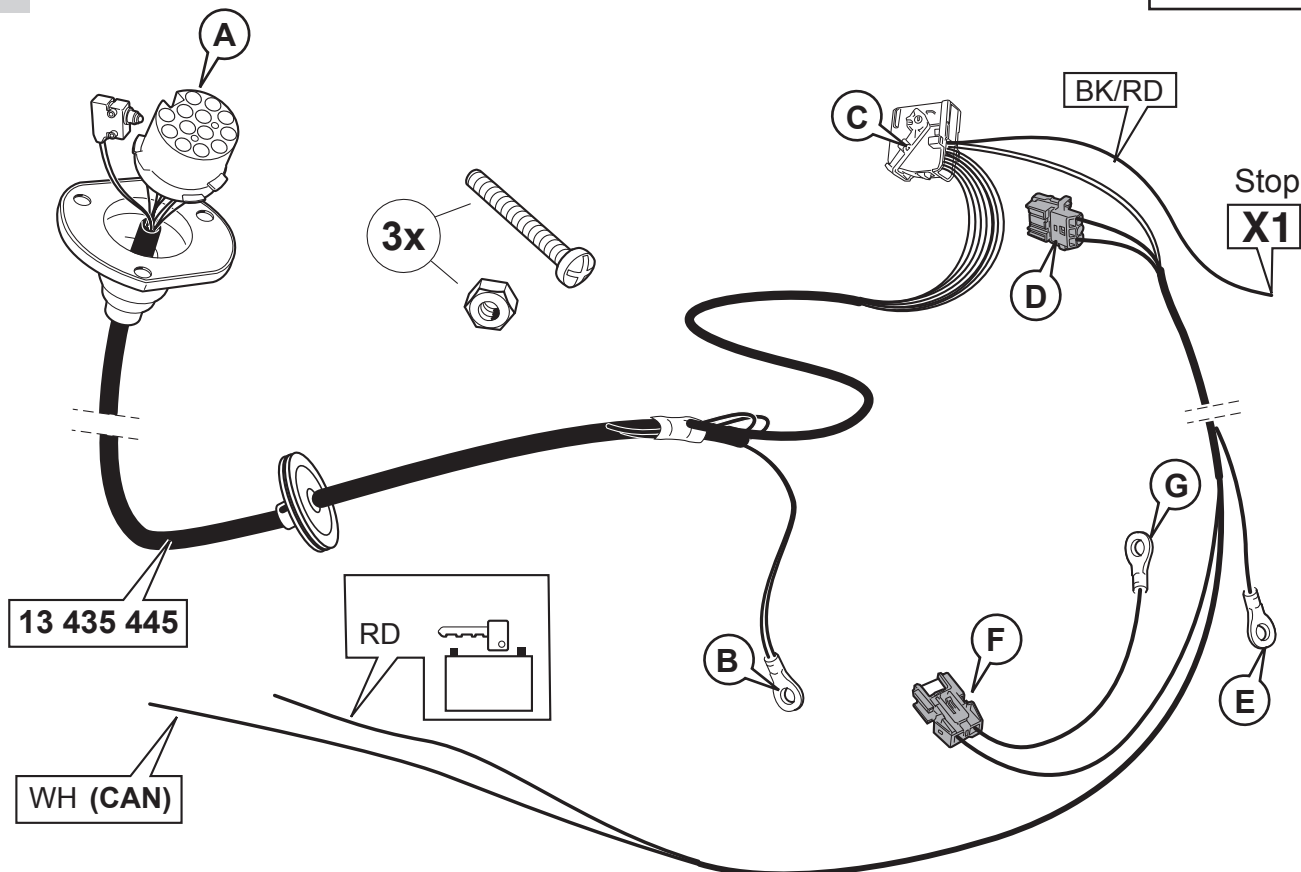

- (A) Einbaueinheit
  - (B) Installationsanleitung
  - (C) Controller de montage
  - (D) Montageanleitung
  - (E) Montageanleitung
  - (F) Montageanleitung
  - (G) Installationsanleitung
  - (H) Absteckbohle
  - (I) Installationsanleitung
  - (J) Installationsanleitung
  - (K) Installationsanleitung
  - (L) Installationsanleitung
  - (M) Installationsanleitung
  - (N) Installationsanleitung
  - (O) Installationsanleitung
  - (P) Installationsanleitung
  - (Q) Installationsanleitung
  - (R) Installationsanleitung
  - (S) Installationsanleitung
  - (T) Installationsanleitung
  - (U) Installationsanleitung
  - (V) Installationsanleitung
  - (W) Installationsanleitung
  - (X) Installationsanleitung
  - (Y) Installationsanleitung
  - (Z) Installationsanleitung
- XX XXX XXX**

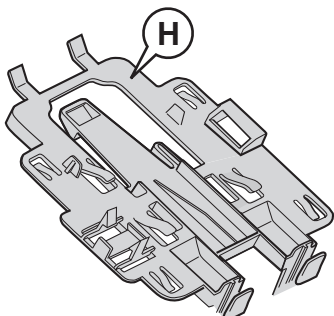

**13 586 468**  
**13 597 659**

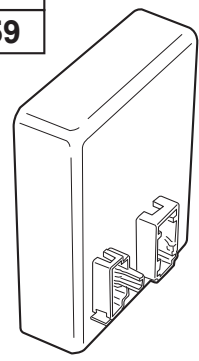



2

## Color Table

	GB	D	E	F	I	P	NL	DK
BU	Blue	Blau	Azul	Bleu	Blu	Azul	Blauw	Blå
BK	Black	Schwarz	Negro	Noir	Nero	Preto	Zwart	Sort
BN	Brown	Braun	Marrón	Marron	Marrone	Castanho	Bruin	Brun
GN	Green	Grün	Verde	Vert	Verde	Verde	Groen	Grøn
GY	Grey	Grau	Gris	Gris	Grigio	Cinzeno	Grijs	Grå
NO	Natural colour	Naturfarben	Color natural	Nature	Colori naturali	Cores naturais	Naturel	Naturfarvet
OG	Orange	Orange	Naranja	Orange	Arancione	Laranja	Oranje	Orange
PK	Pink	Rosa	Rosa	Rose	Rosa	Rosa	Rosé	Rosa
RD	Red	Rot	Rojo	Rouge	Rosso	Vermelho	Rood	Rød
WH	White	Weiß	Blanco	Blanc	Bianco	Branco	Wit	Hvid
YE	Yellow	Gelb	Amarillo	Jaune	Giallo	Amarelo	Geel	Gul
VT	Violet	Violett	Violeta	Violet	Viola	Violeta	Violet	Violet

	N	S	SF	CZ	H	PL	GR
BU	Blå	Blå	Sininen	Modrá	Kék	Niebieska	Μπλε
BK	Sort	Svart	Musta	Černá	Fekete	Czarna	Μαύρο
BN	Brun	Brun	Ruskea	Hnědá	Barna	Brazowa	Καφέ
GN	Grønn	Grøn	Vihreä	Zelená	Zöld	Zielona	Πράσινο
GY	Grå	Grå	Harmaa	Šedá	Szürke	Szara	Γκρι
NO	Naturfarger	Naturfärger	Luonnonväri	Přírodní barva	Természetes színű	Barwy naturalne	Φυσικά χρώματα
OG	Orange	Orange	Oranssi	Oranžová	Narancs	Pomarańczowa	Πορτοκαλί
PK	Rosa	Rosa	Rosa	Růžová	Rózsaszín	Różowa	Ροζ
RD	Rød	Röd	Punainen	Červená	Piros	Czerwona	Κόκκινο
WH	Hvit	Vit	Valkoinen	Bílá	Fehér	Biata	Λευκό
YE	Gul	Gul	Keltainen	Žlutá	Sárga	Żółta	Κίτρινο
VT	Fiolett	Violett	Violetti	Fialová	Ibolyakék	Fioletowa	Μοβ

3

**Astra-K  
HB5**

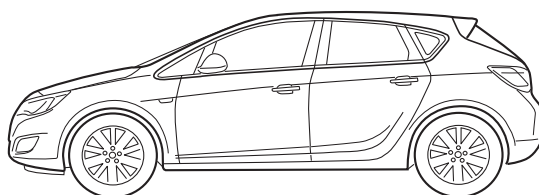

4 - 26

**Astra-K  
Sportstourer**

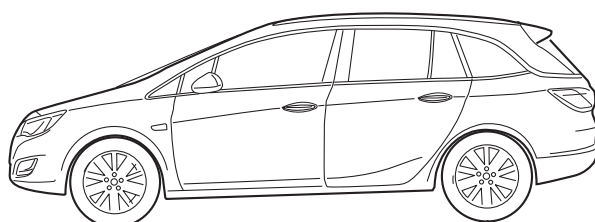

27 - 51

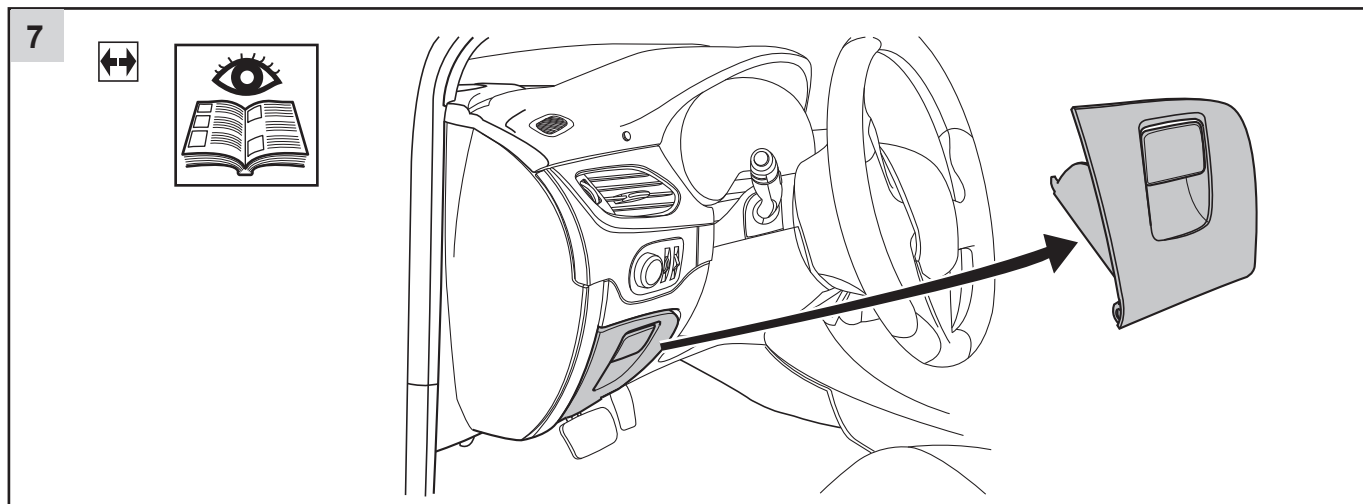
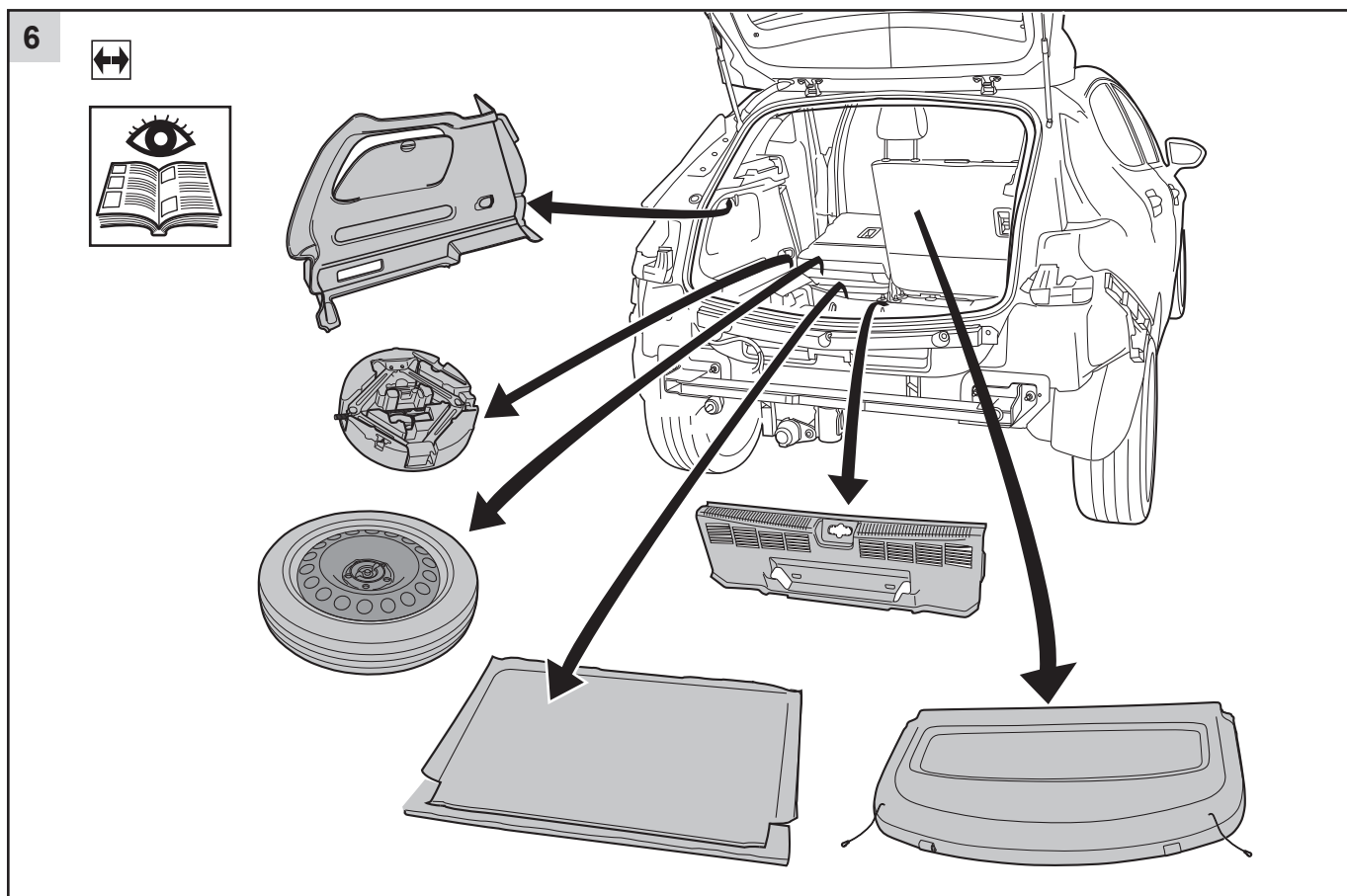
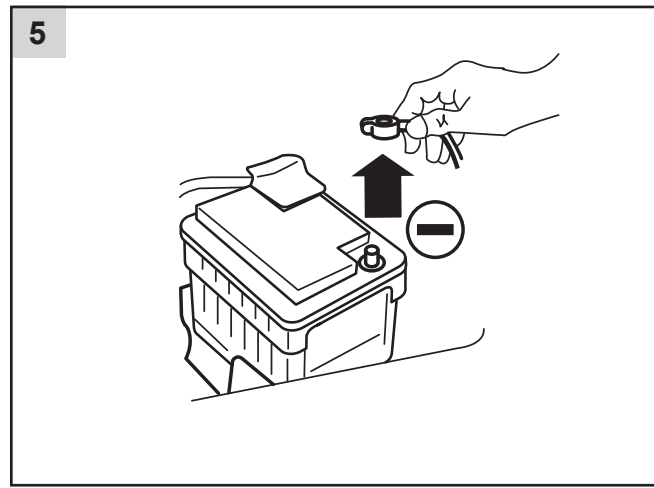
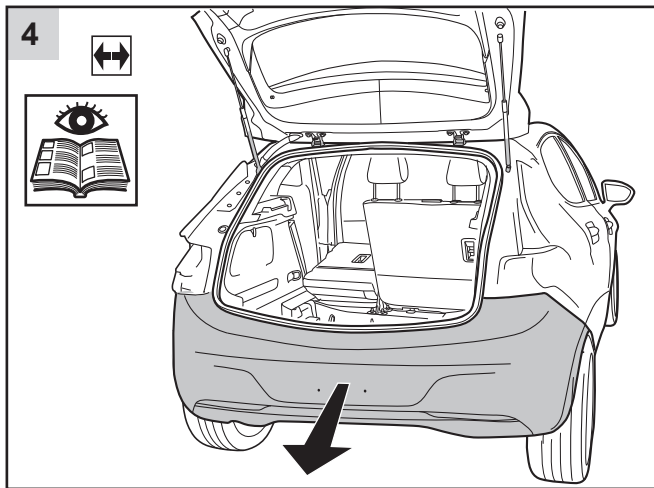

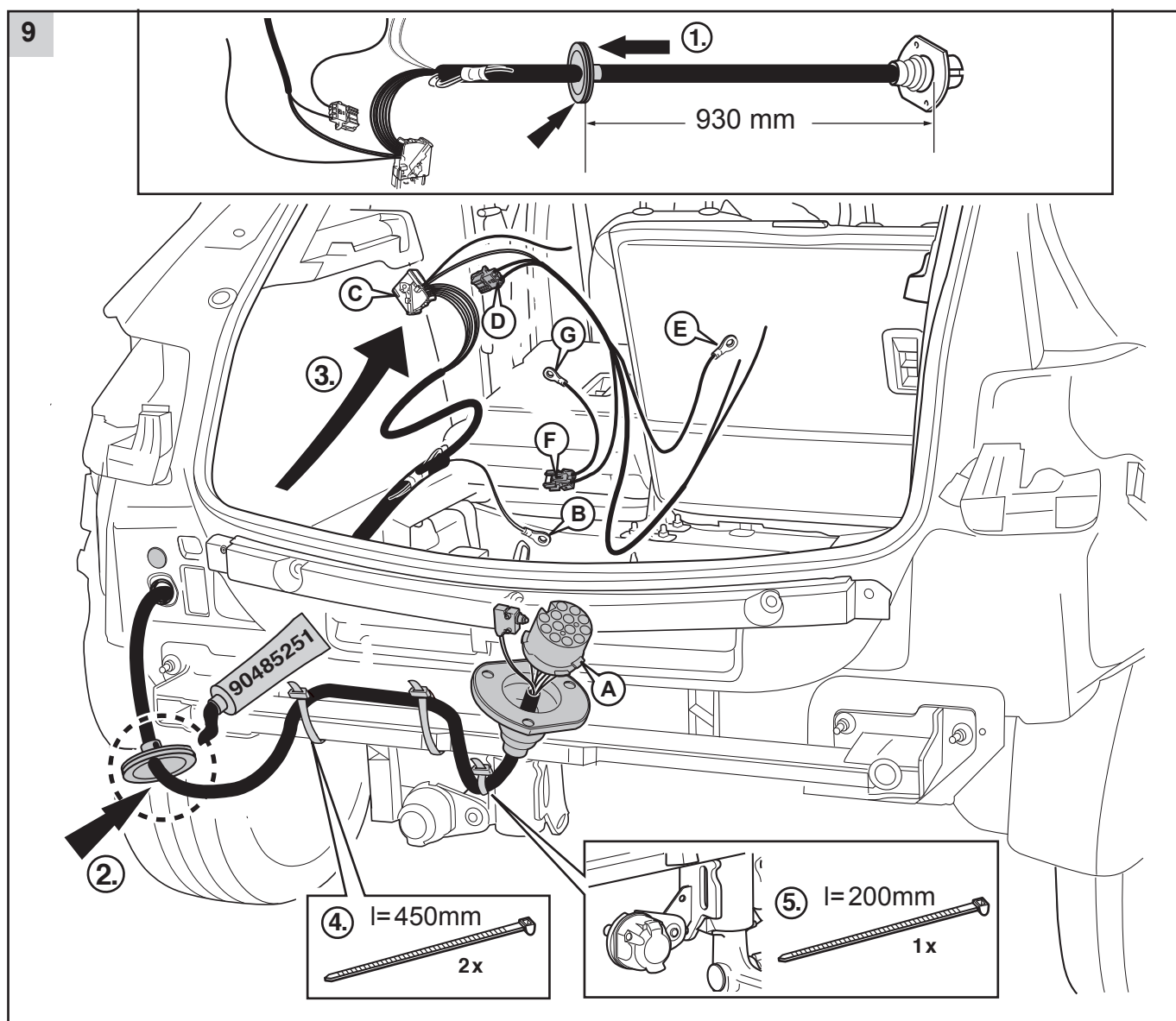
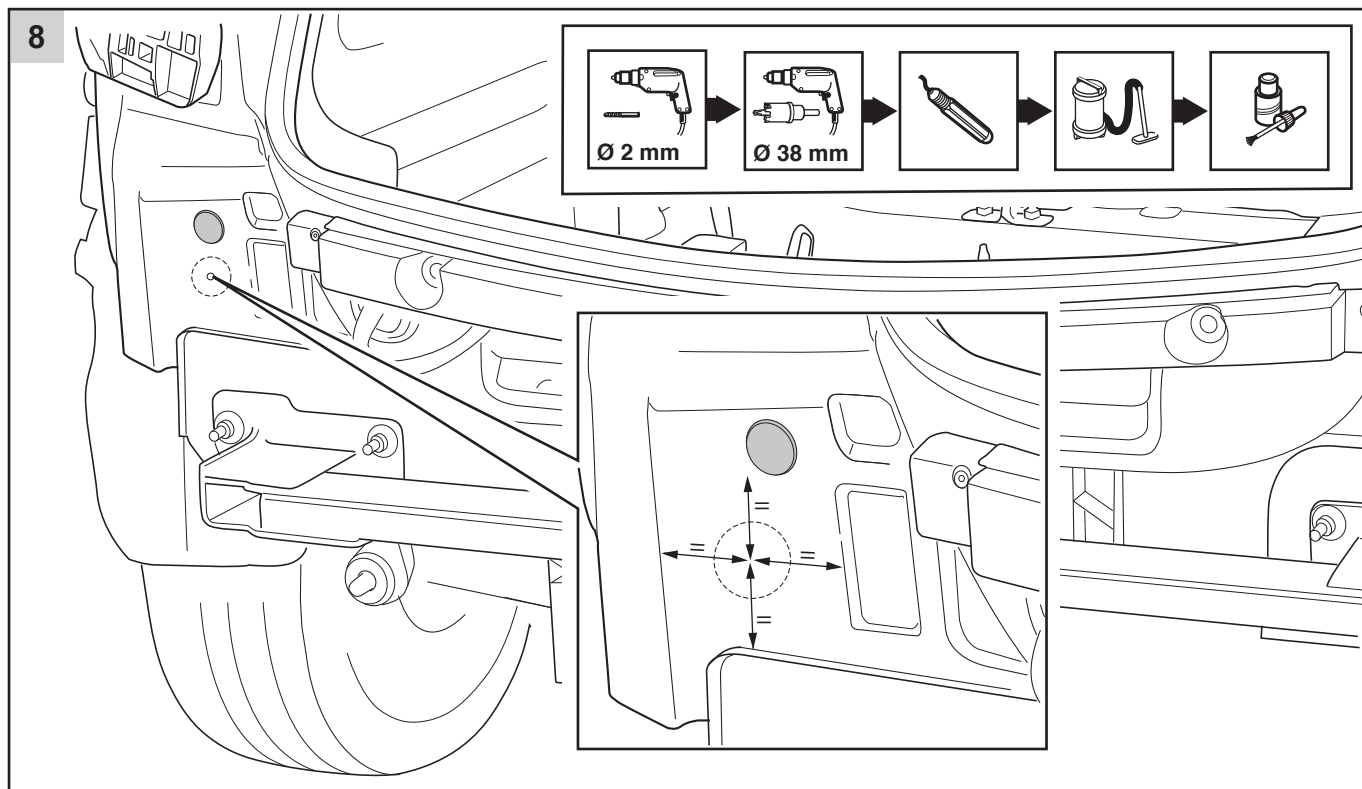

10

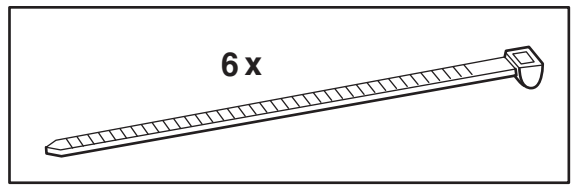
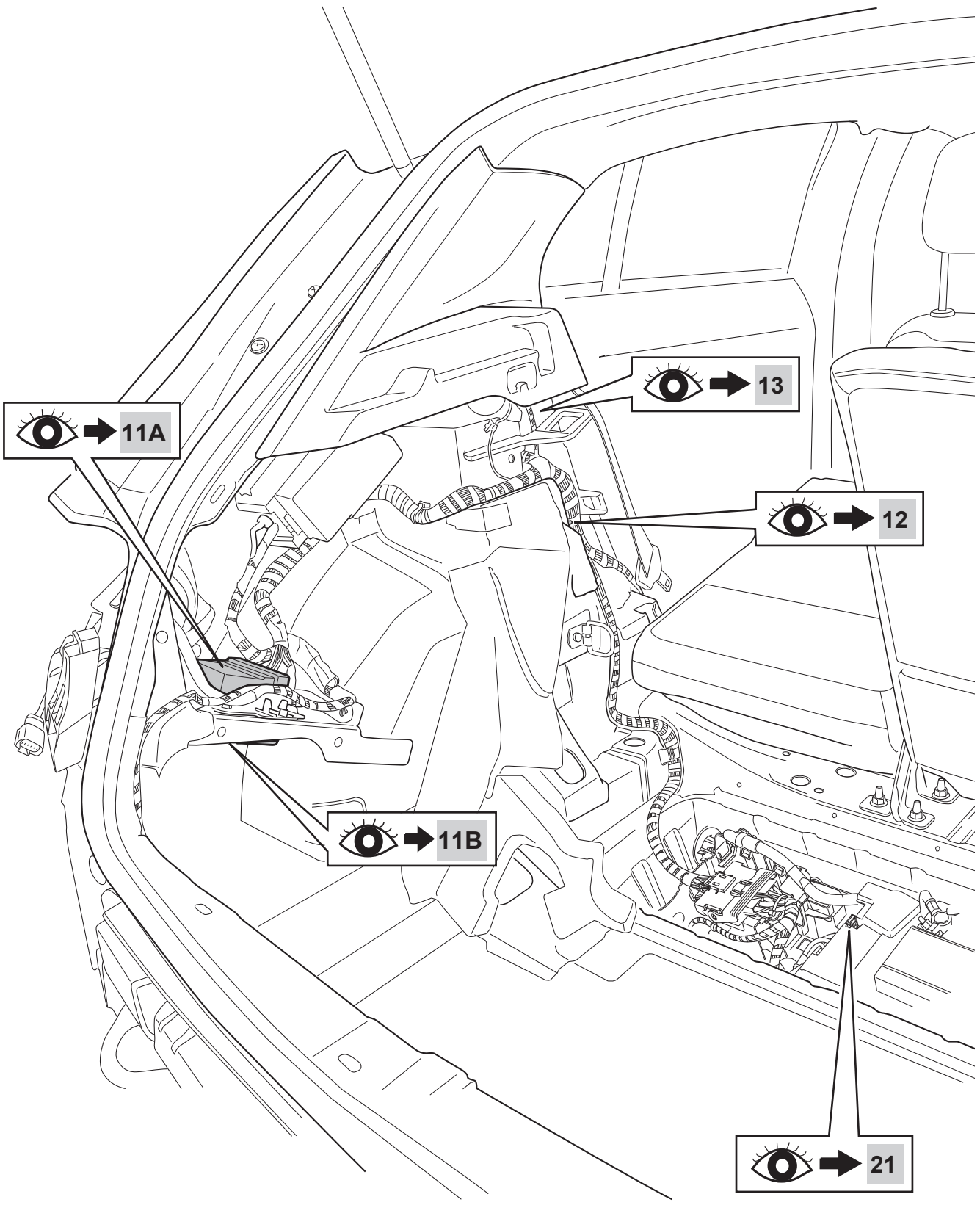

11

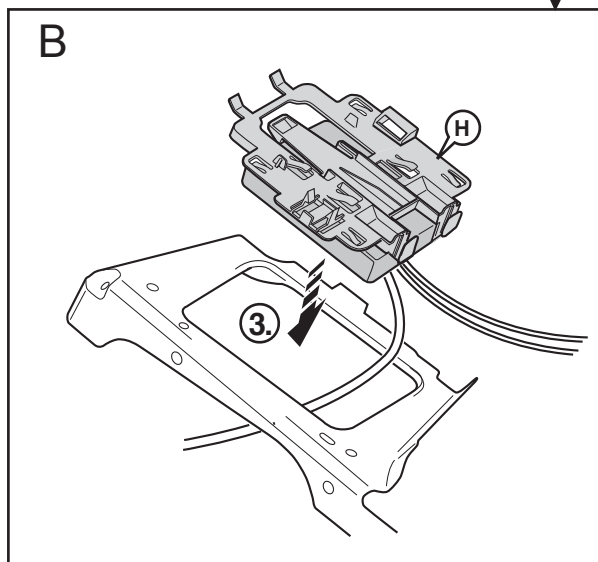
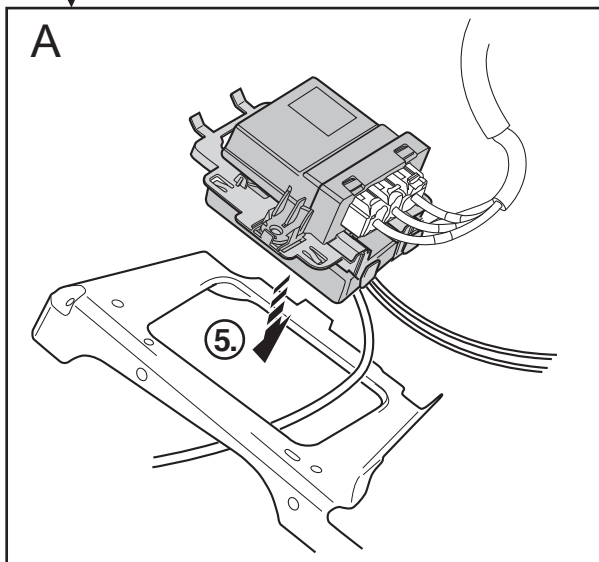
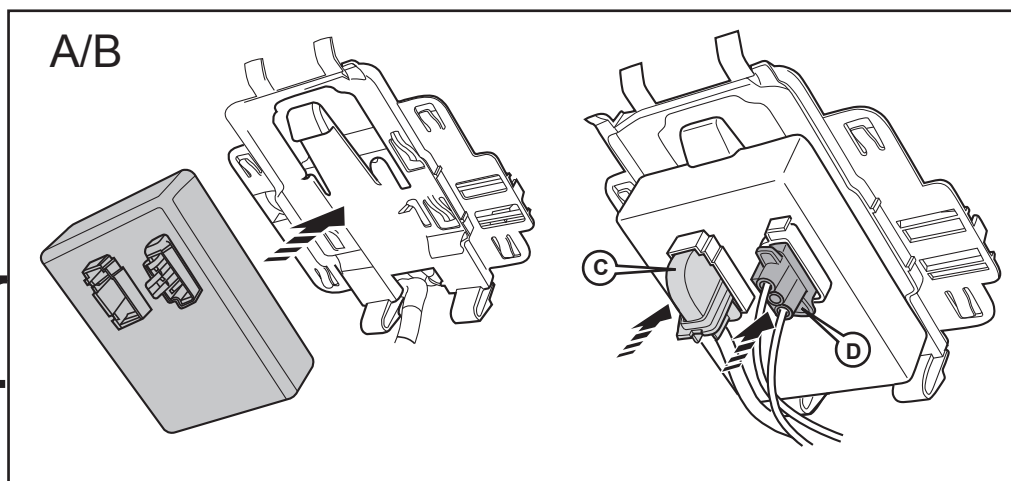
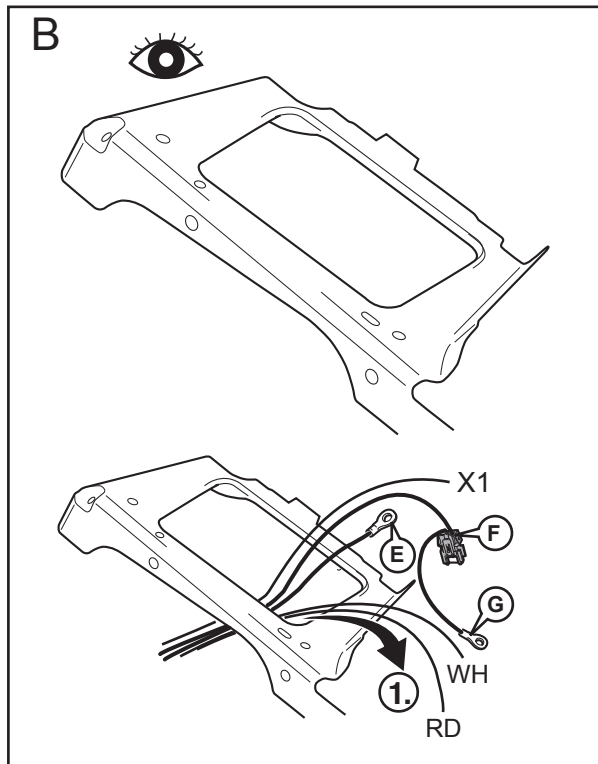
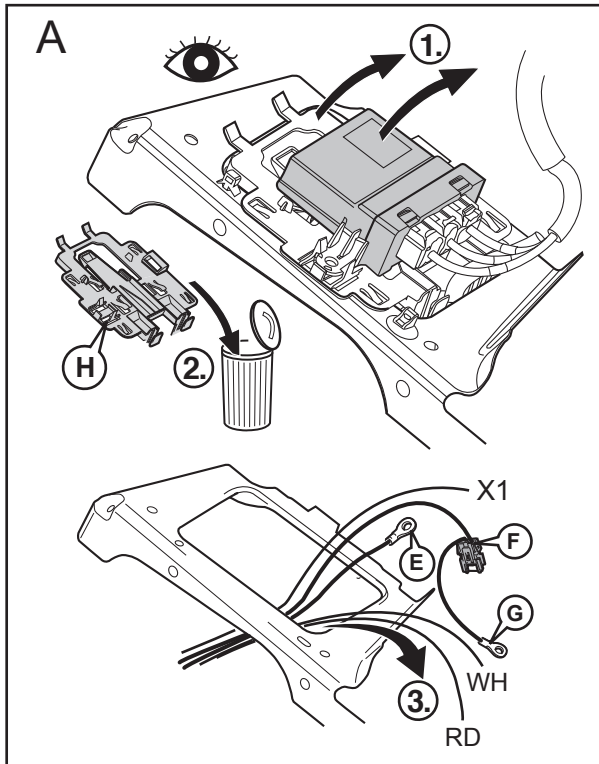

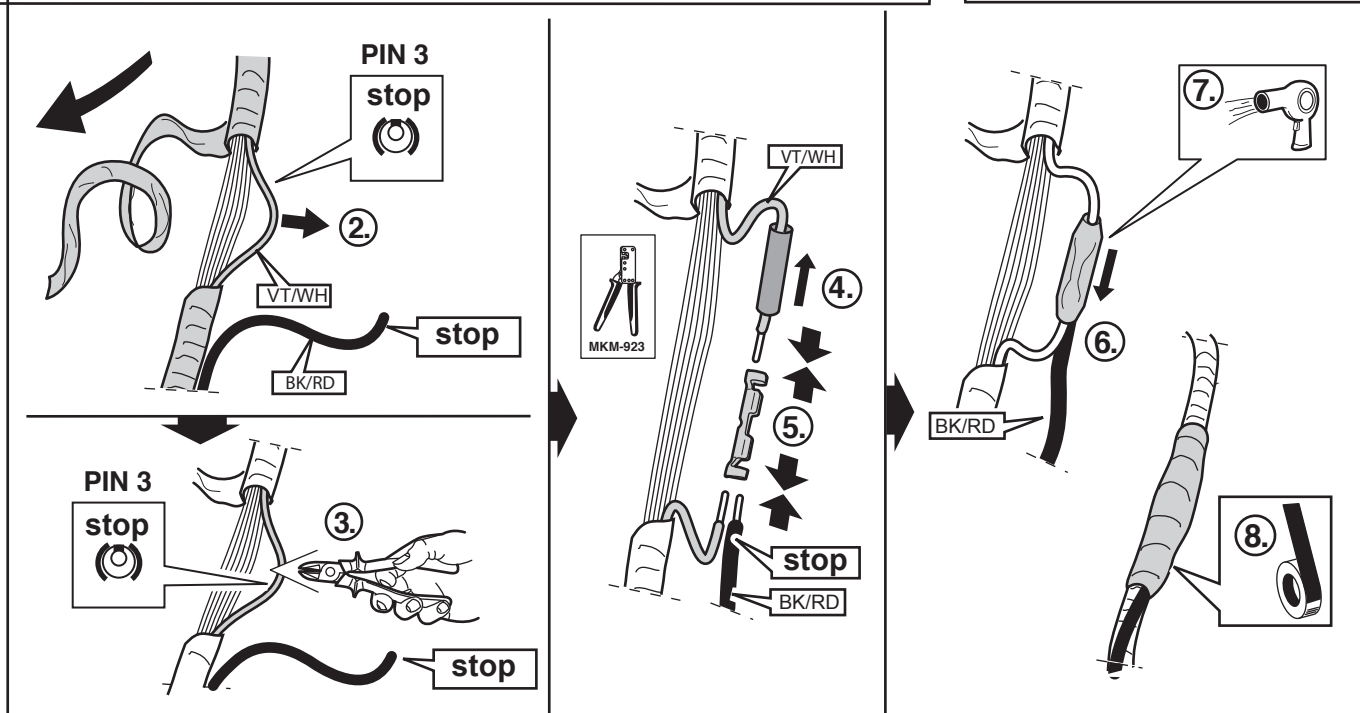
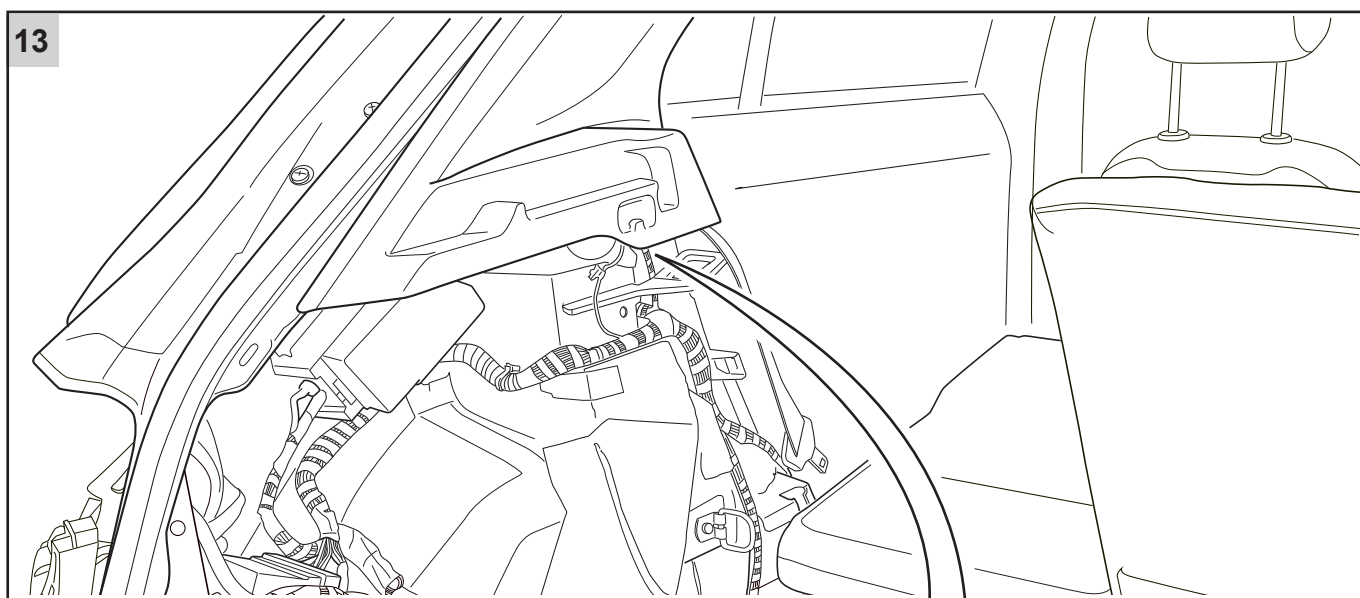
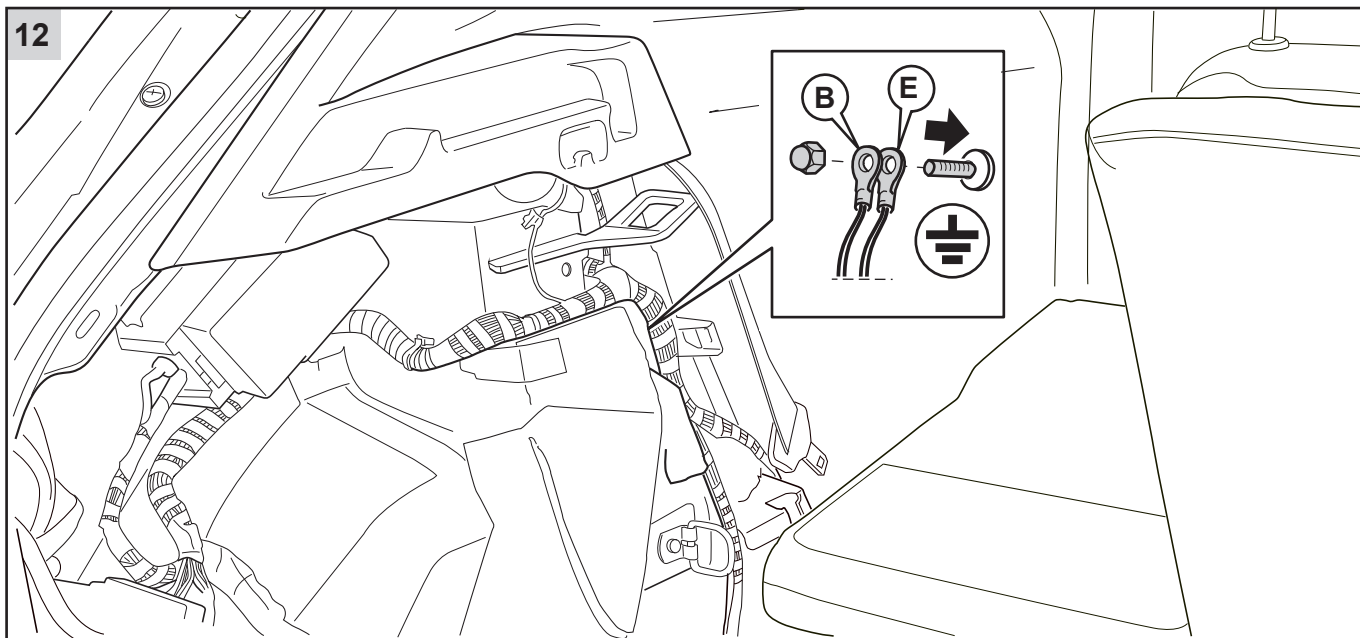

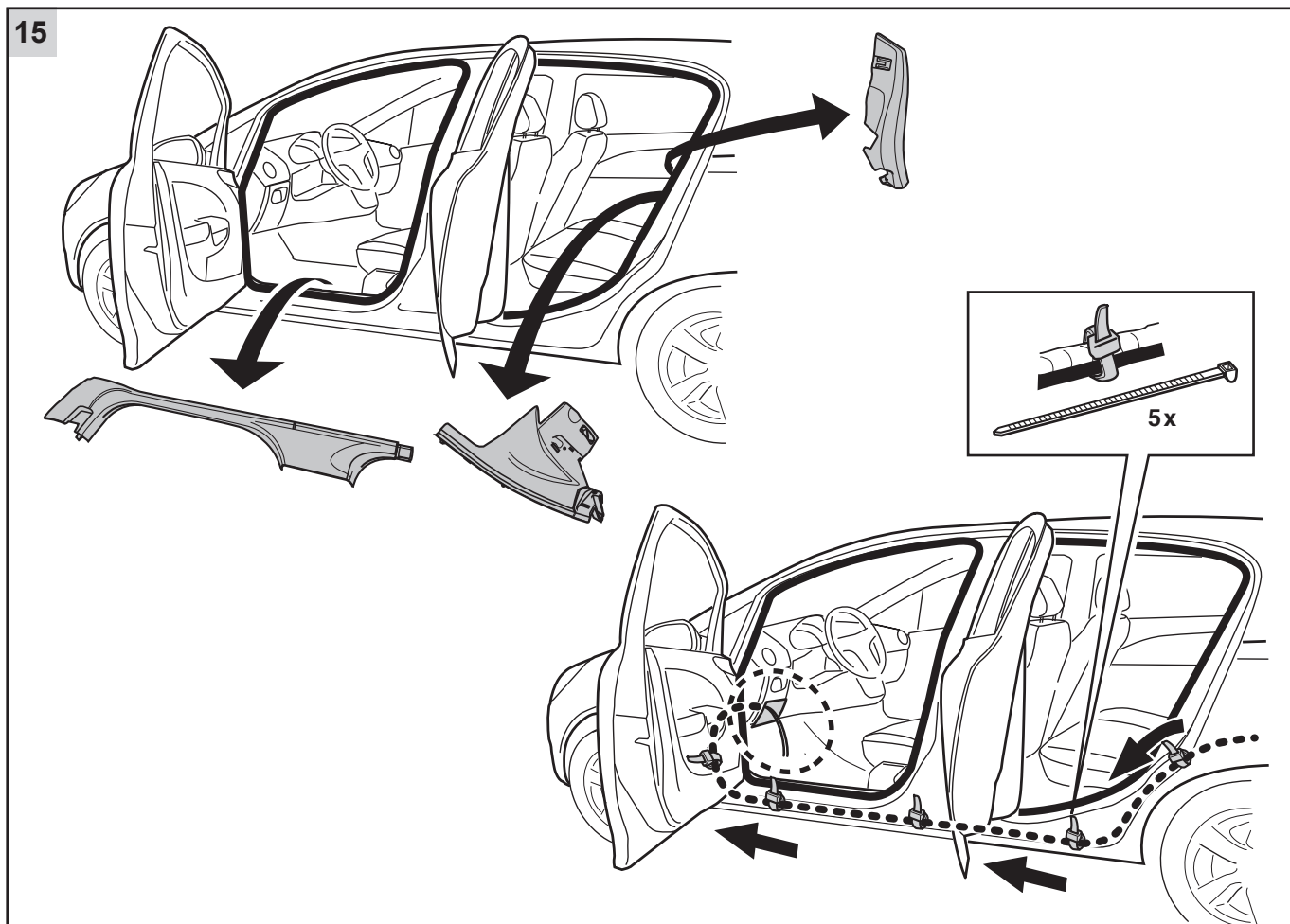
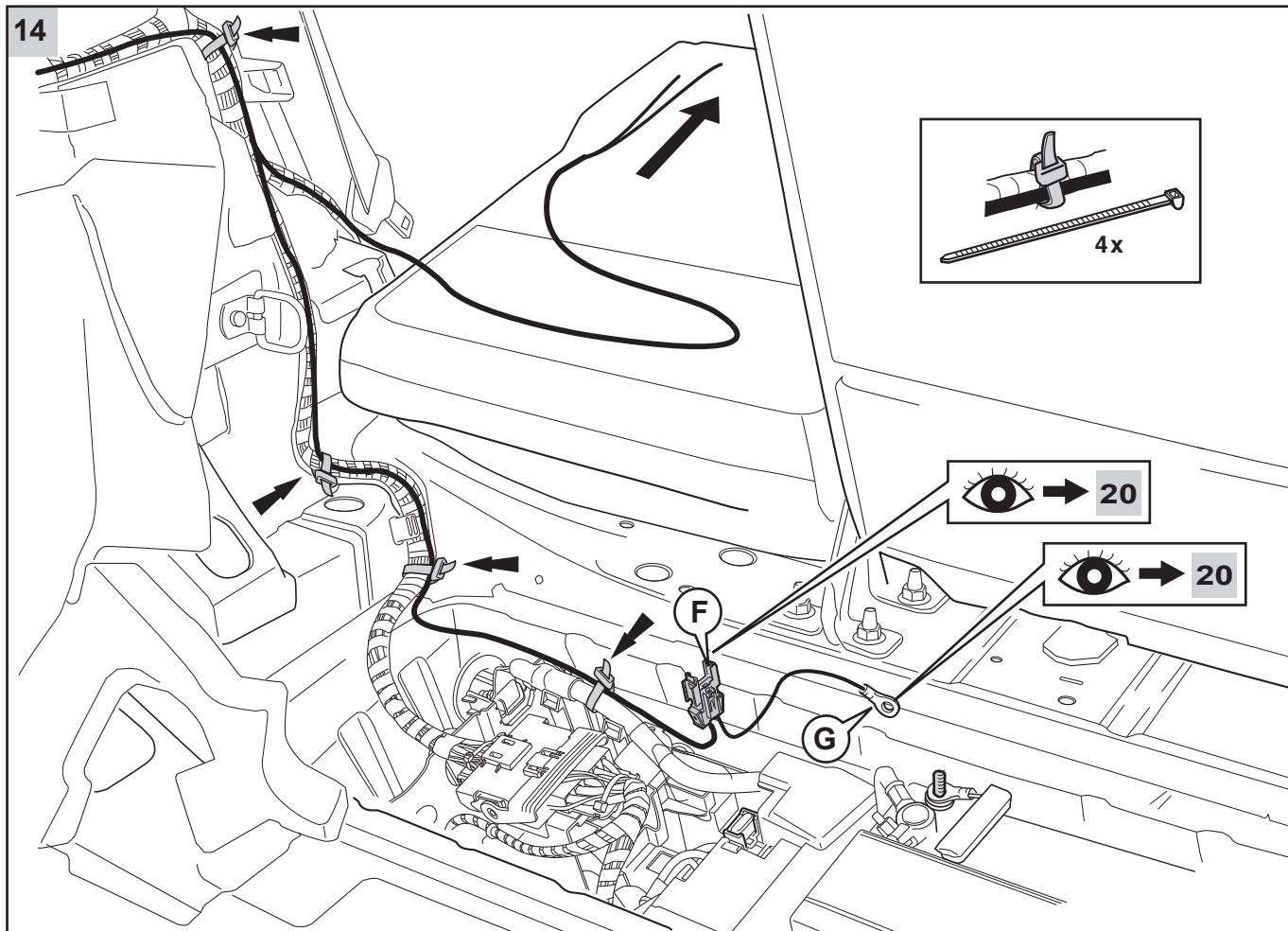

16

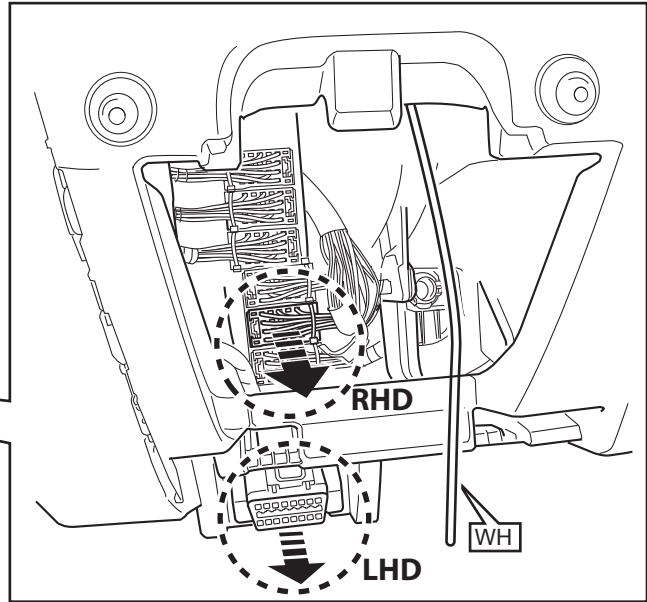
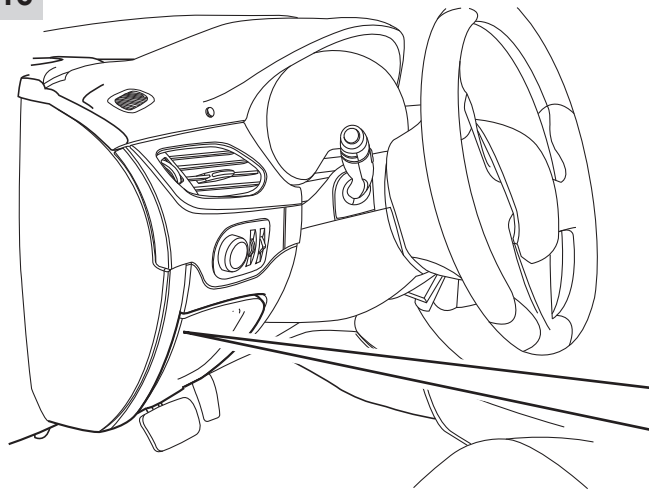

17

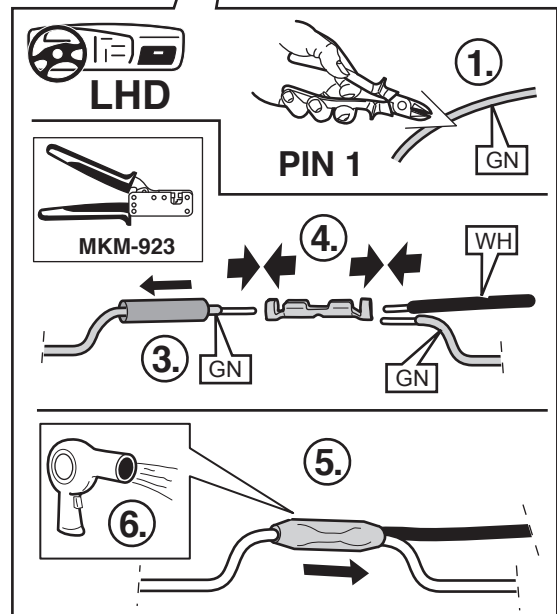
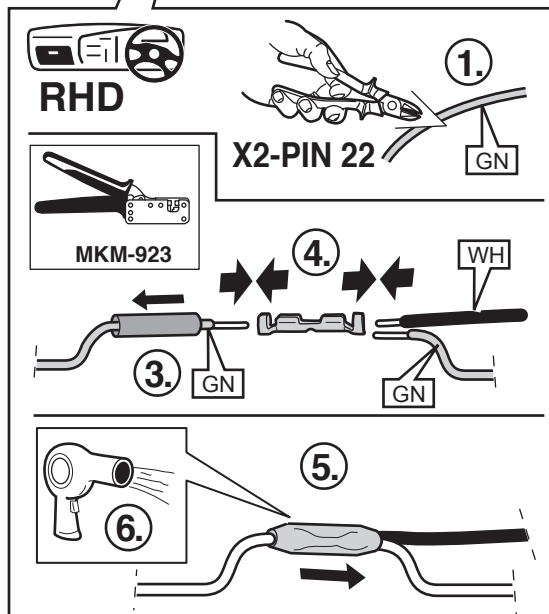
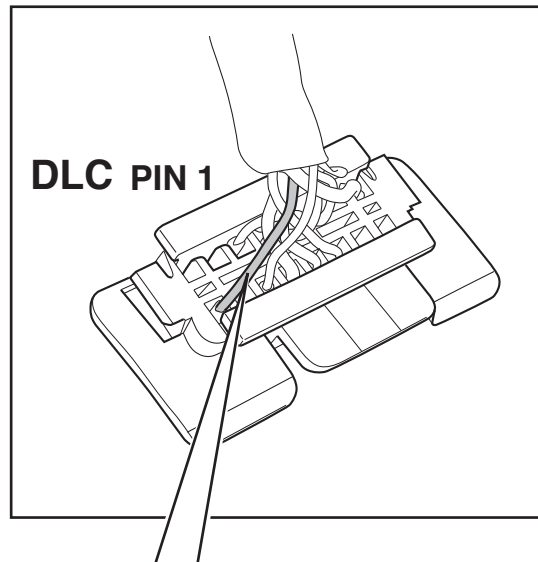
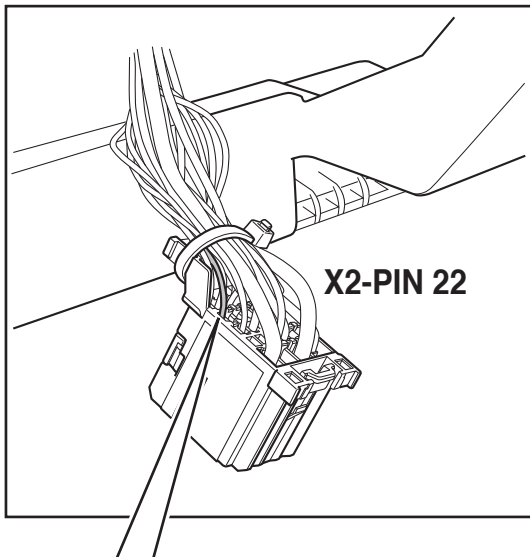



18

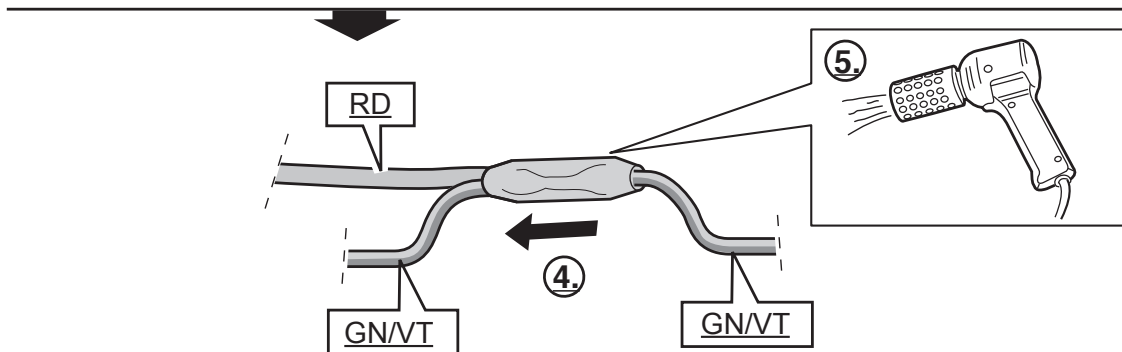
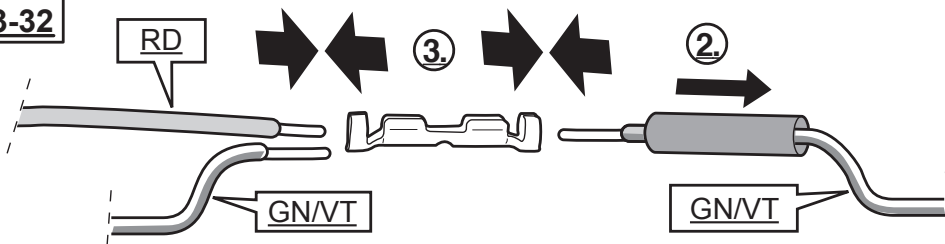
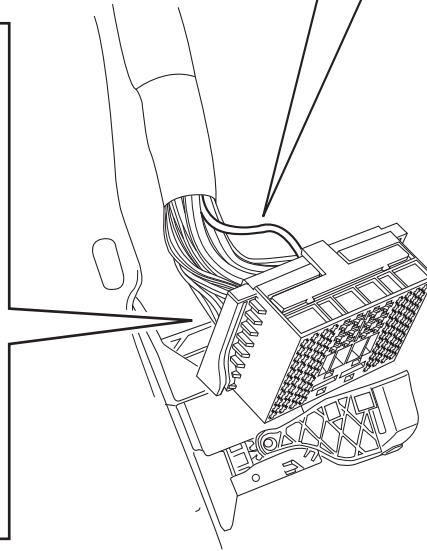
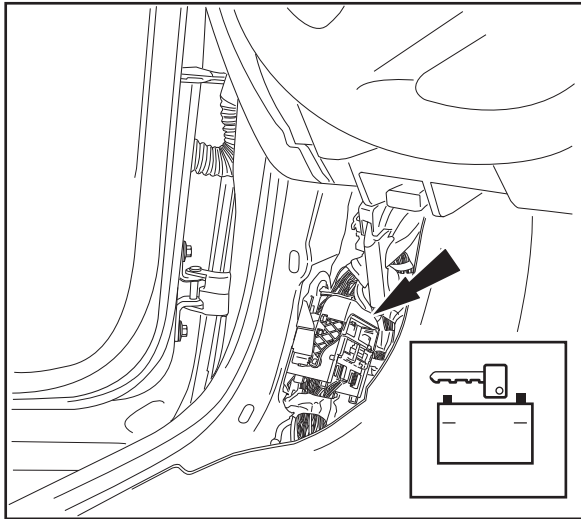
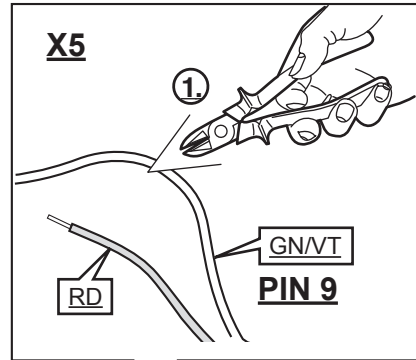
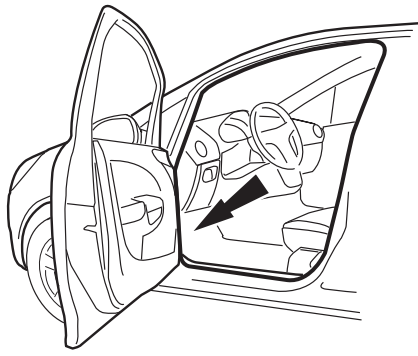

19

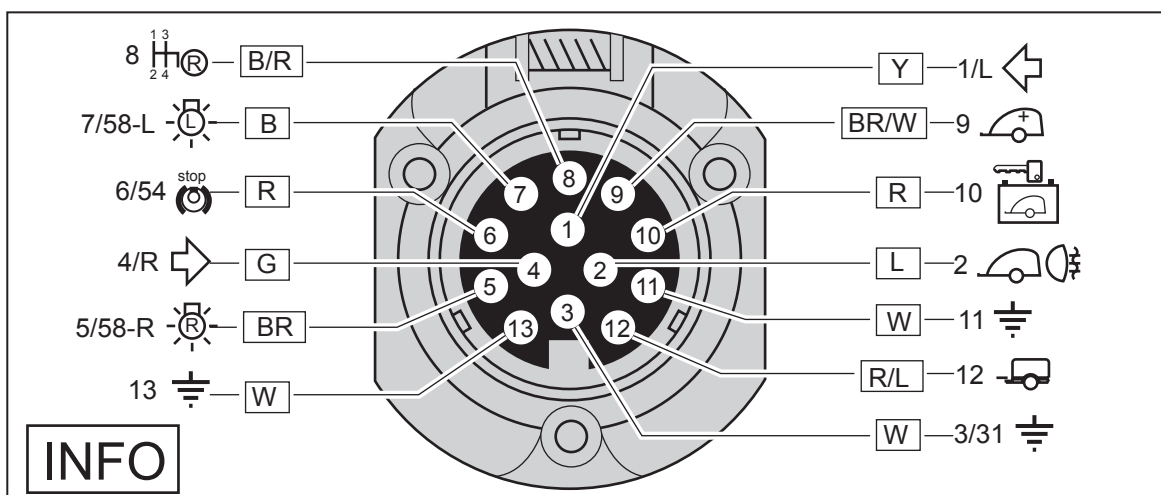
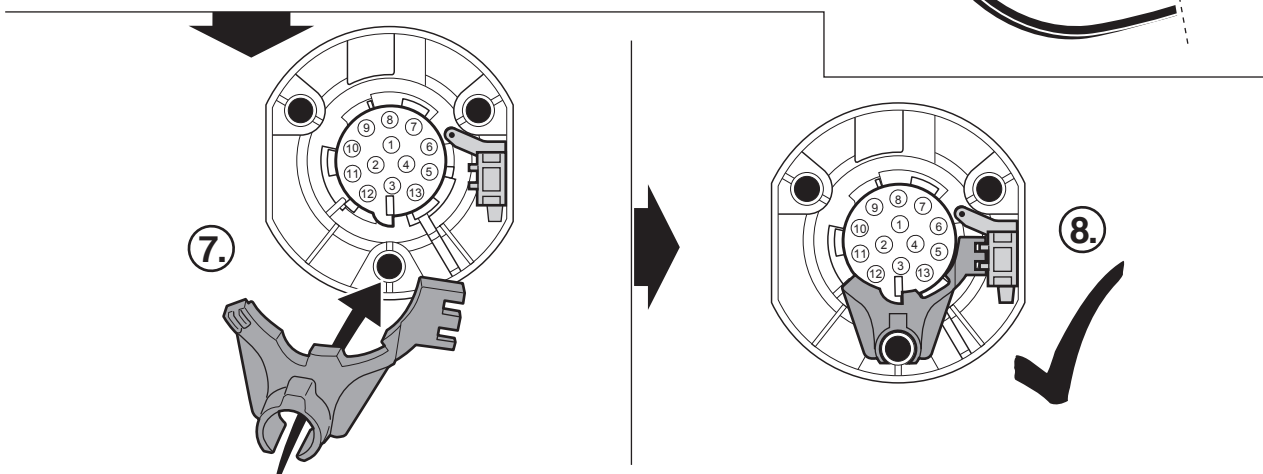
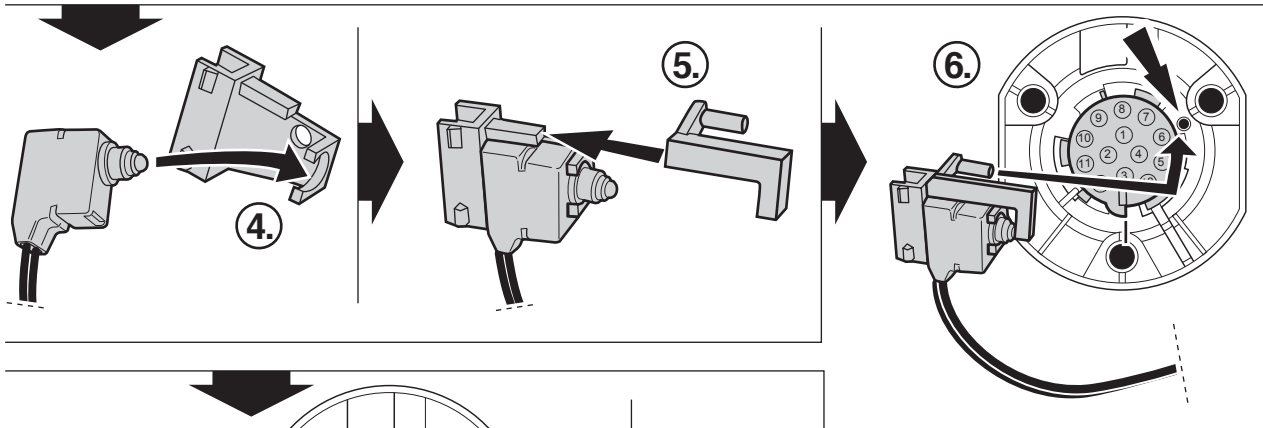
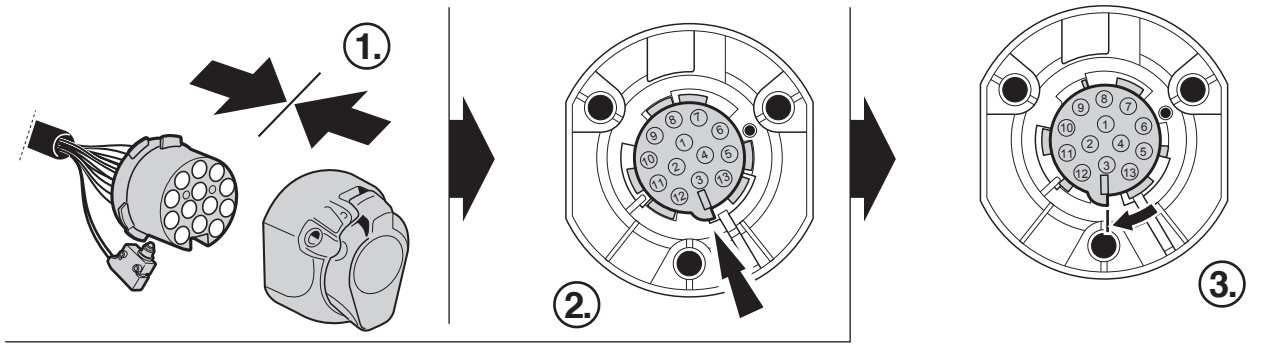
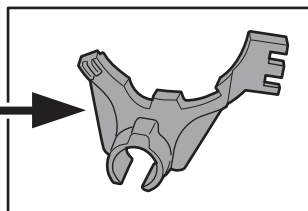

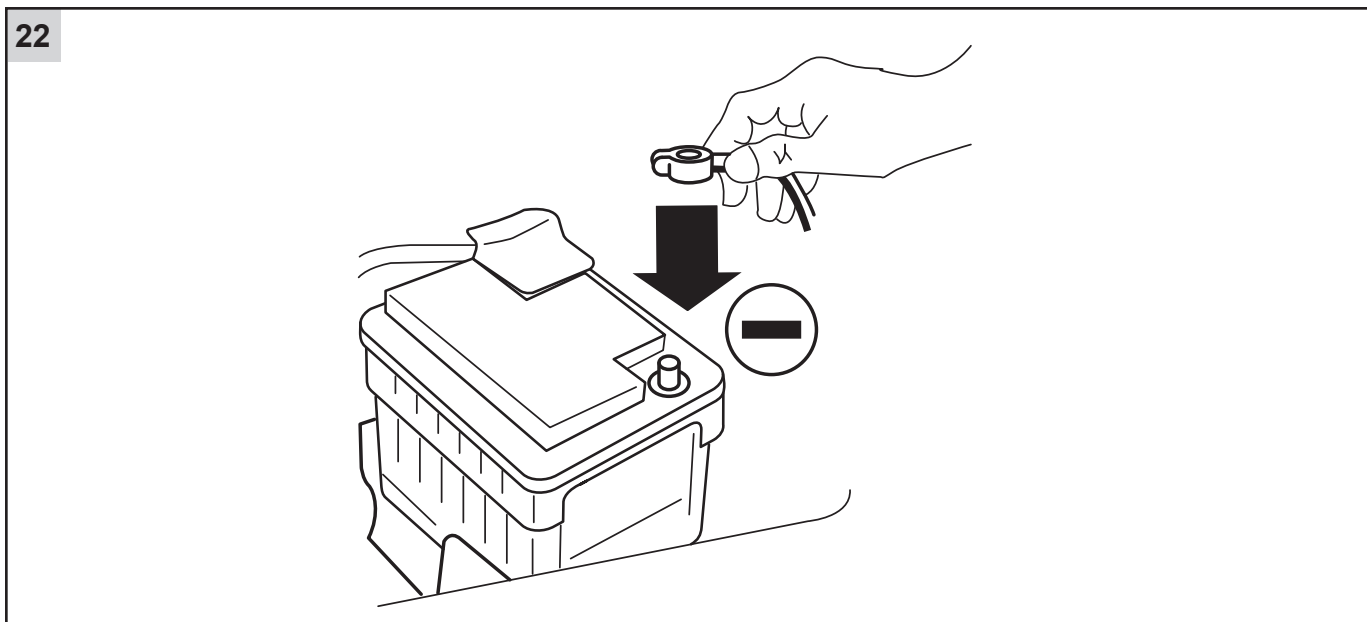
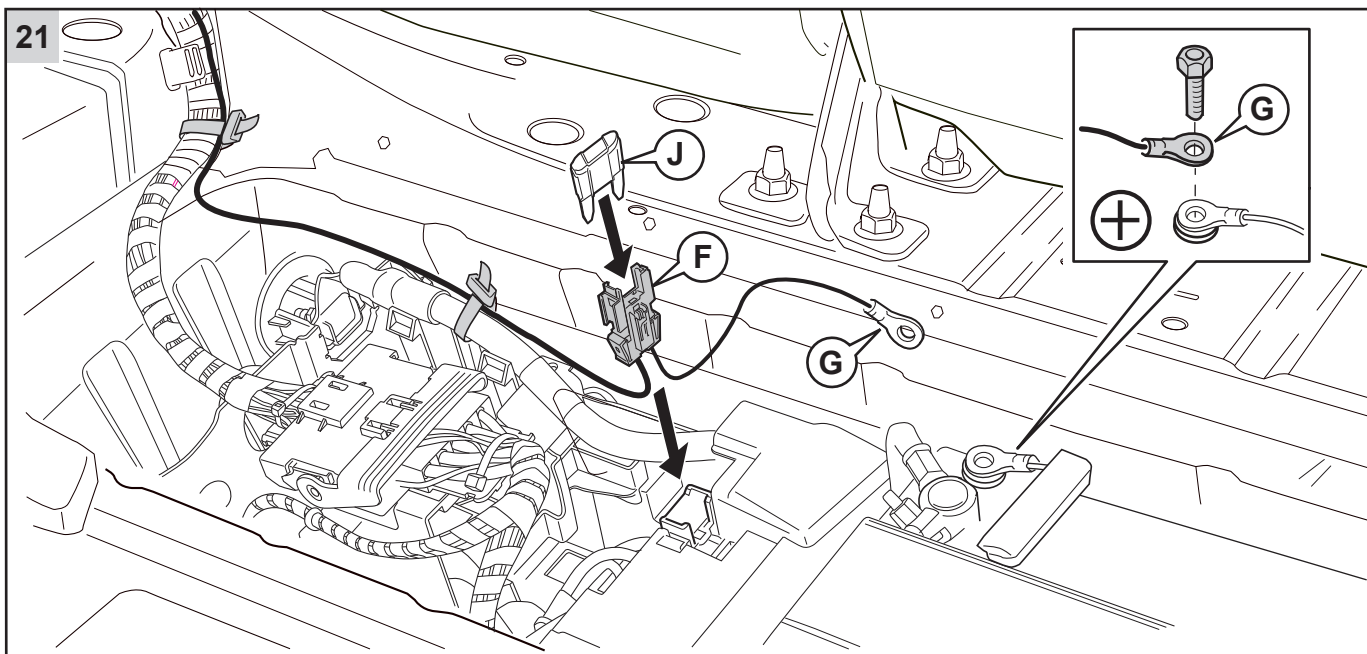
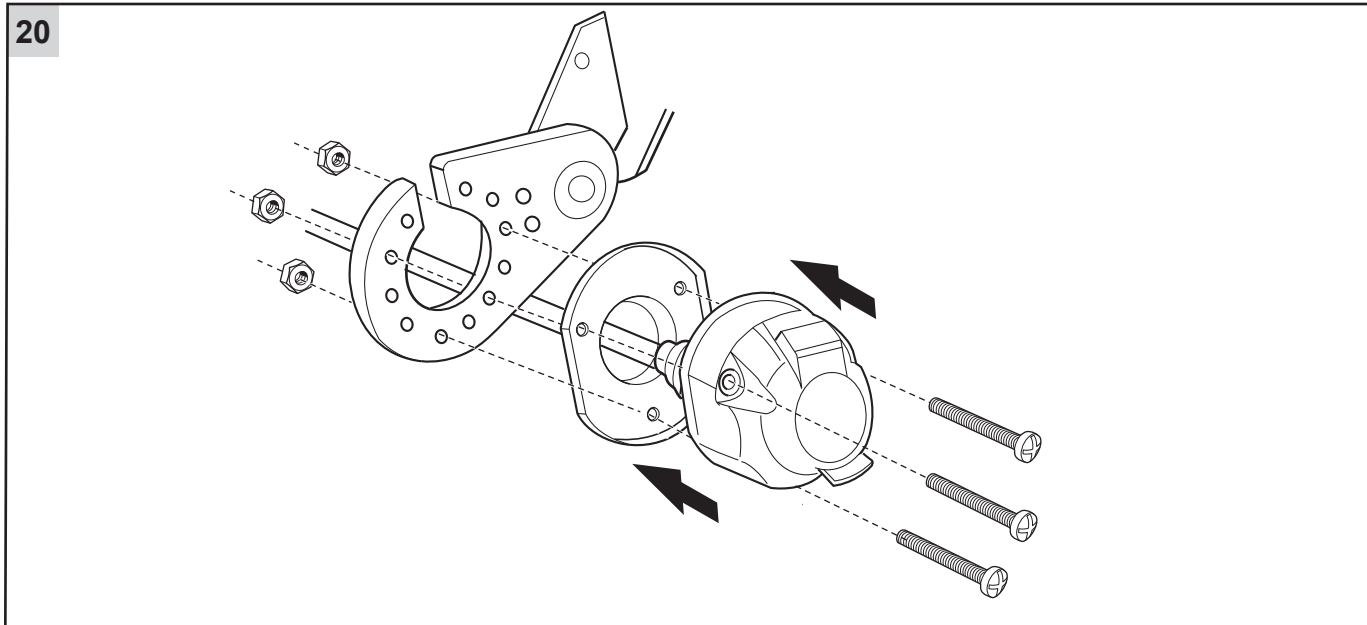

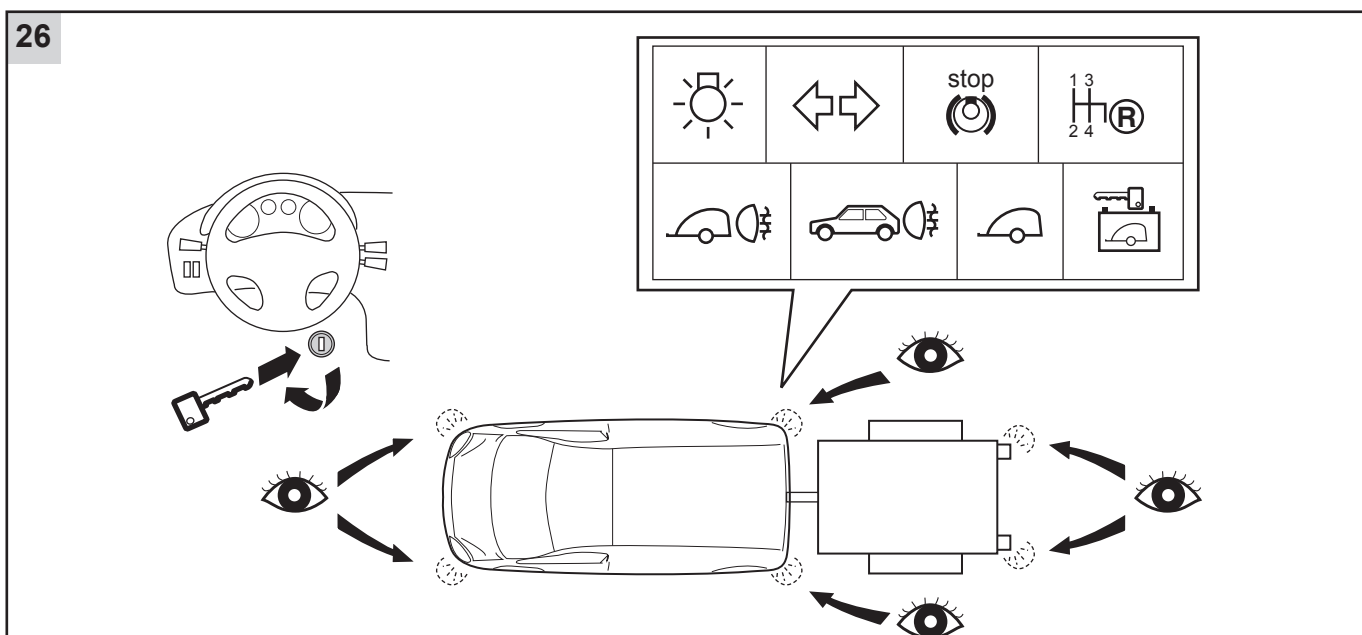
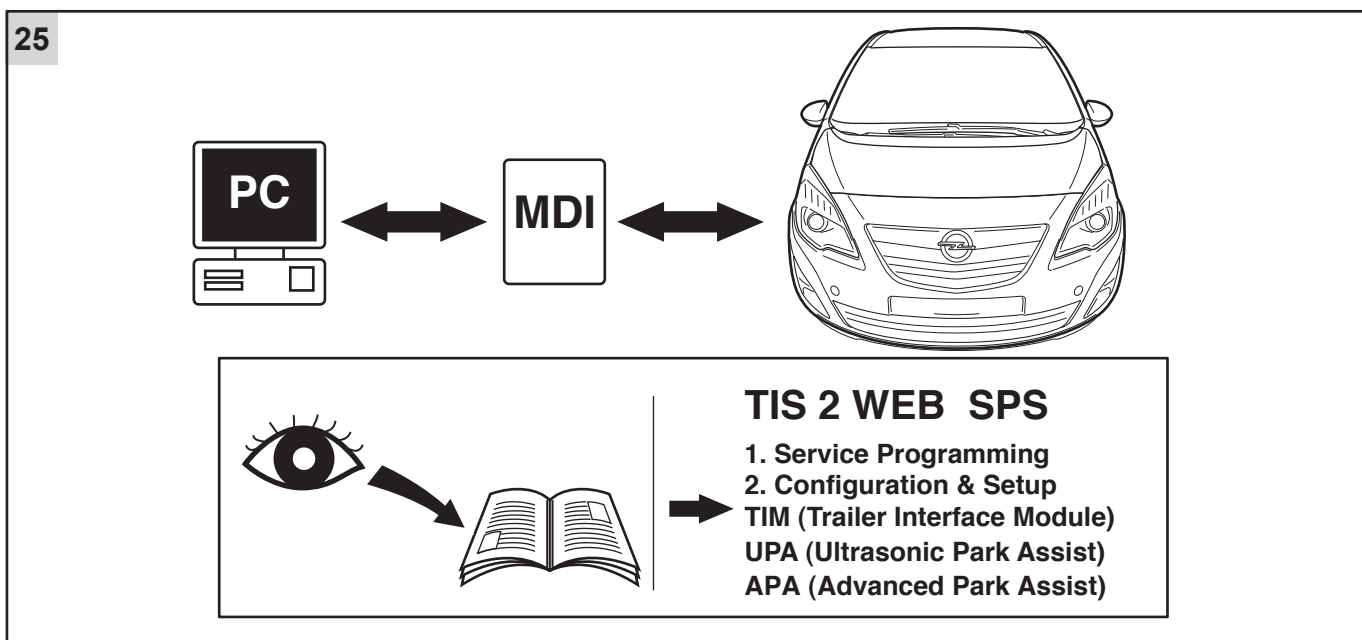
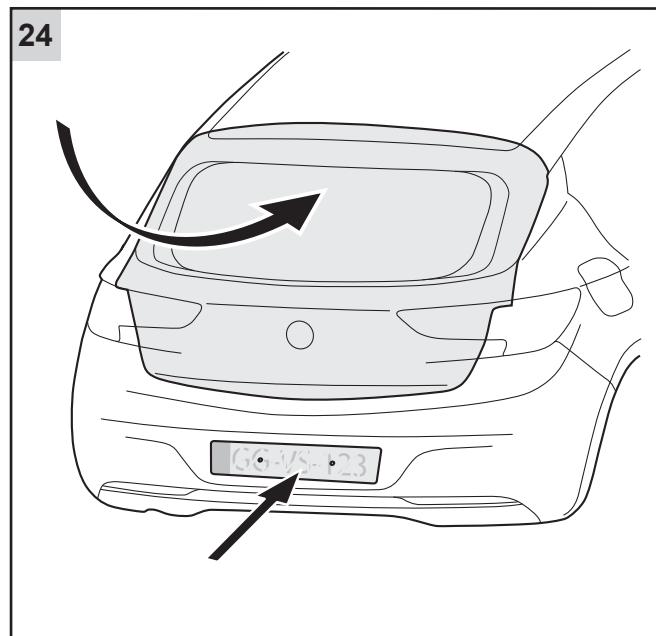
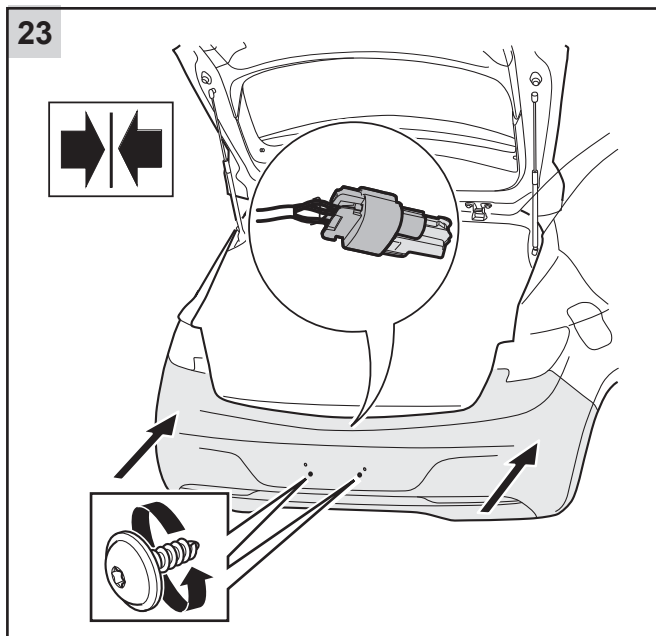

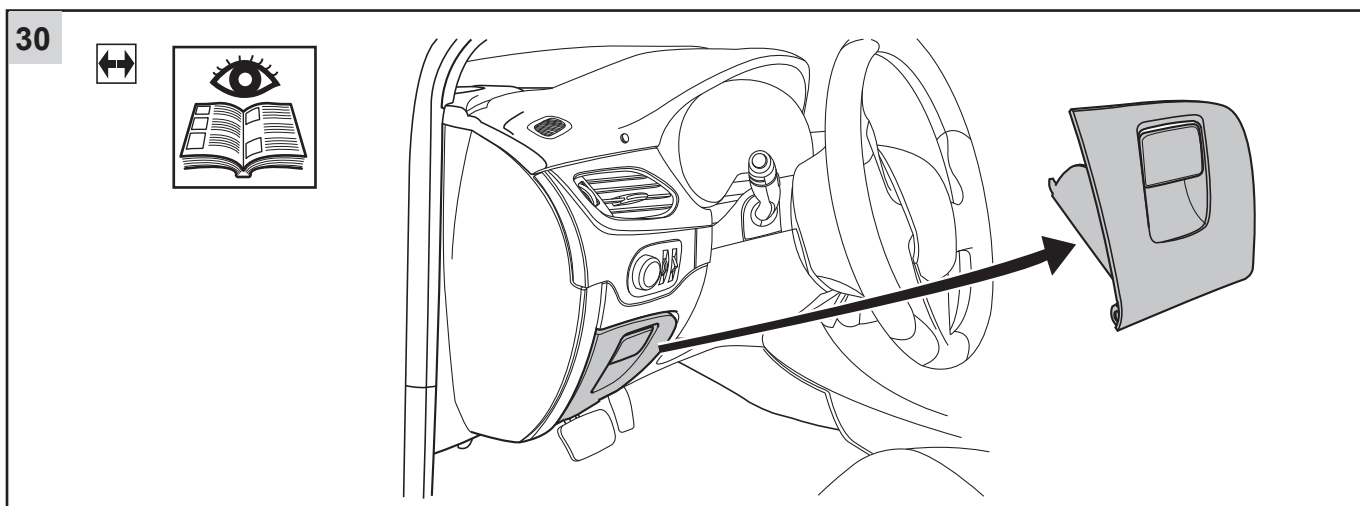
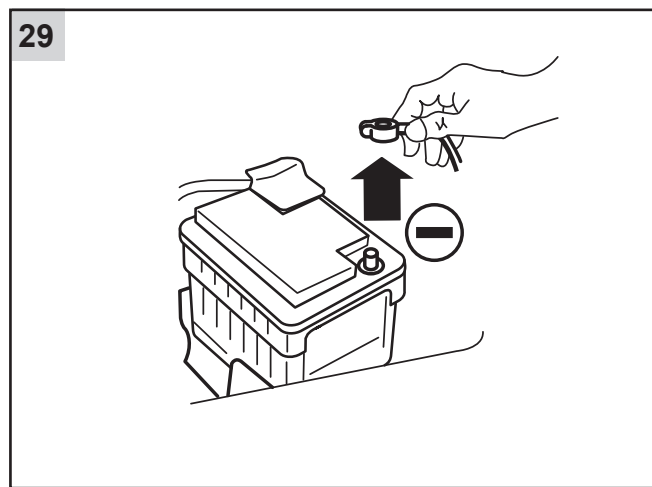
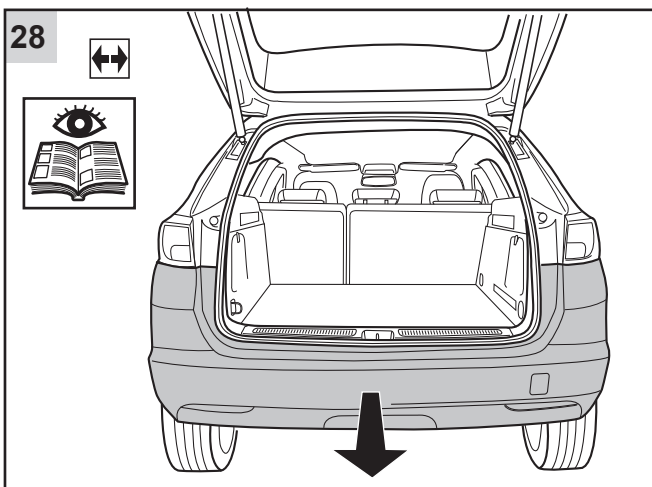
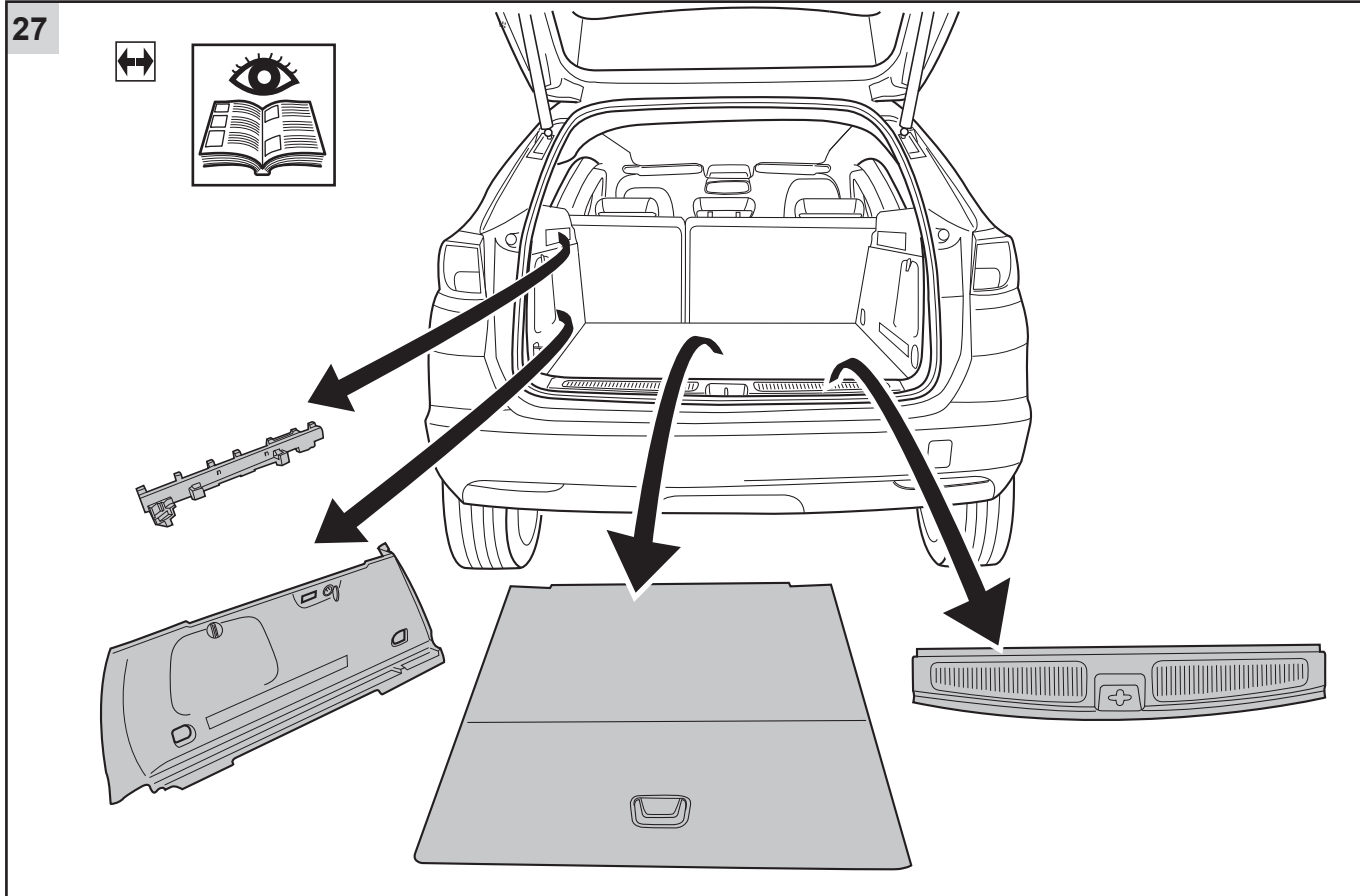

31

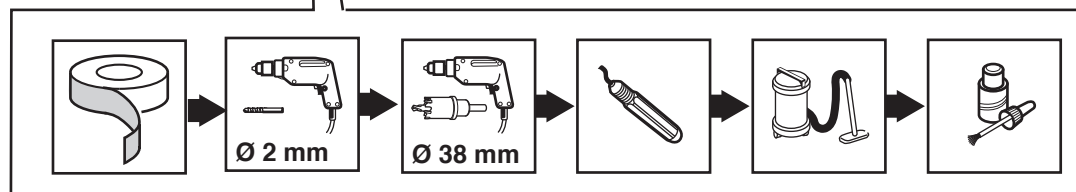
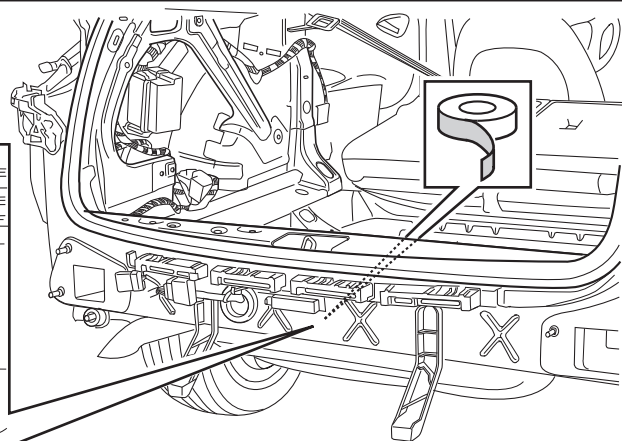
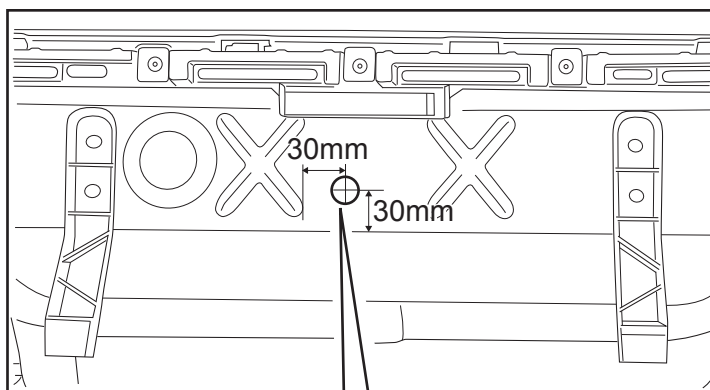

32

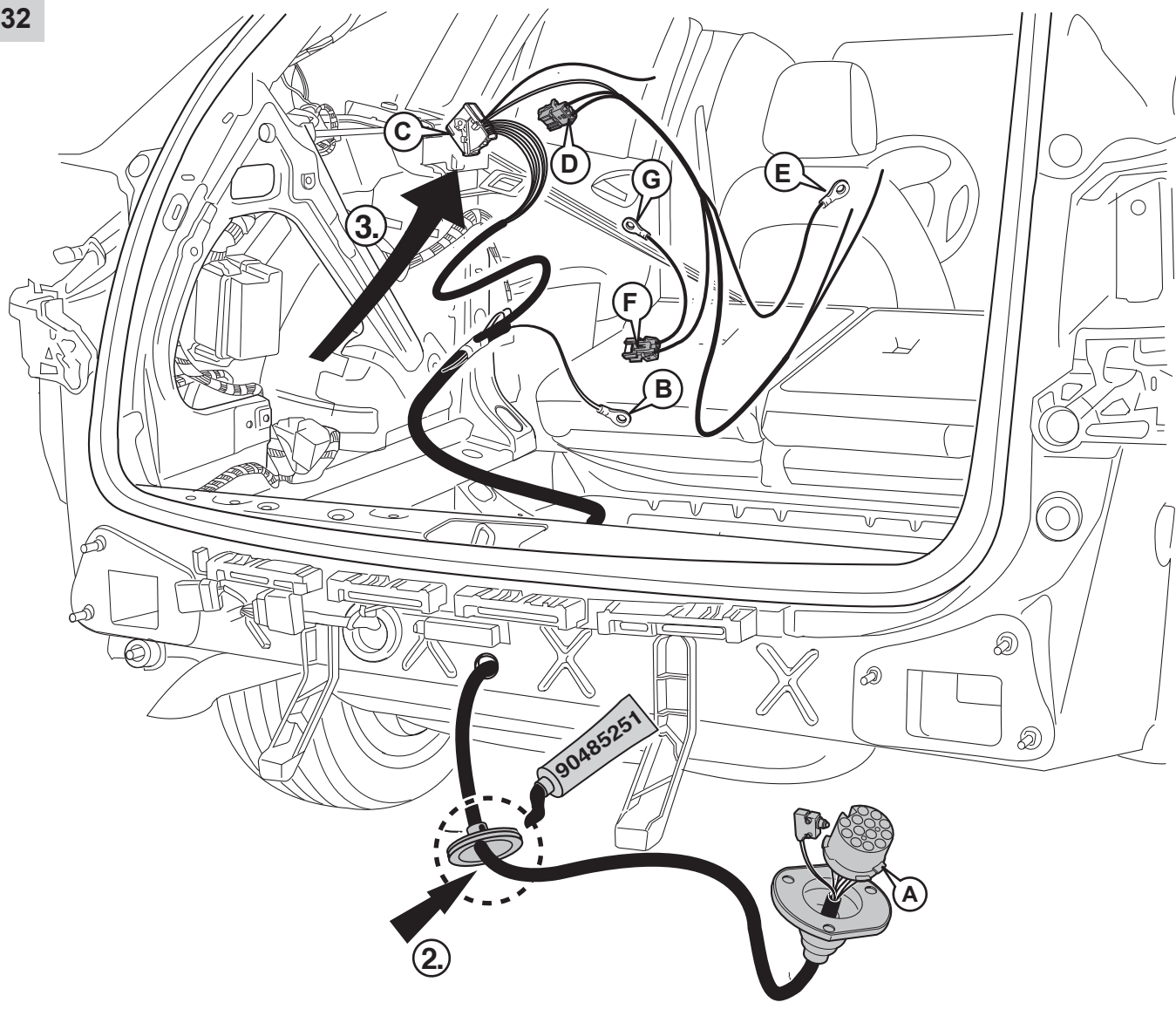

33

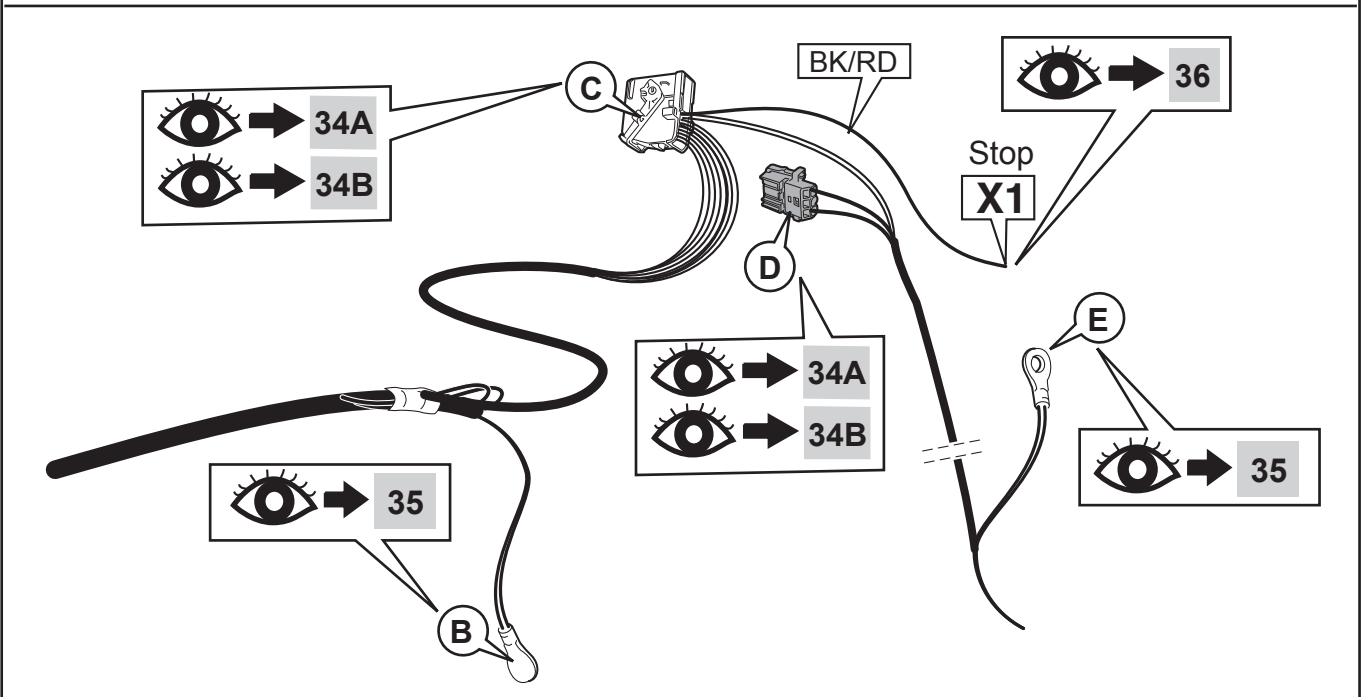
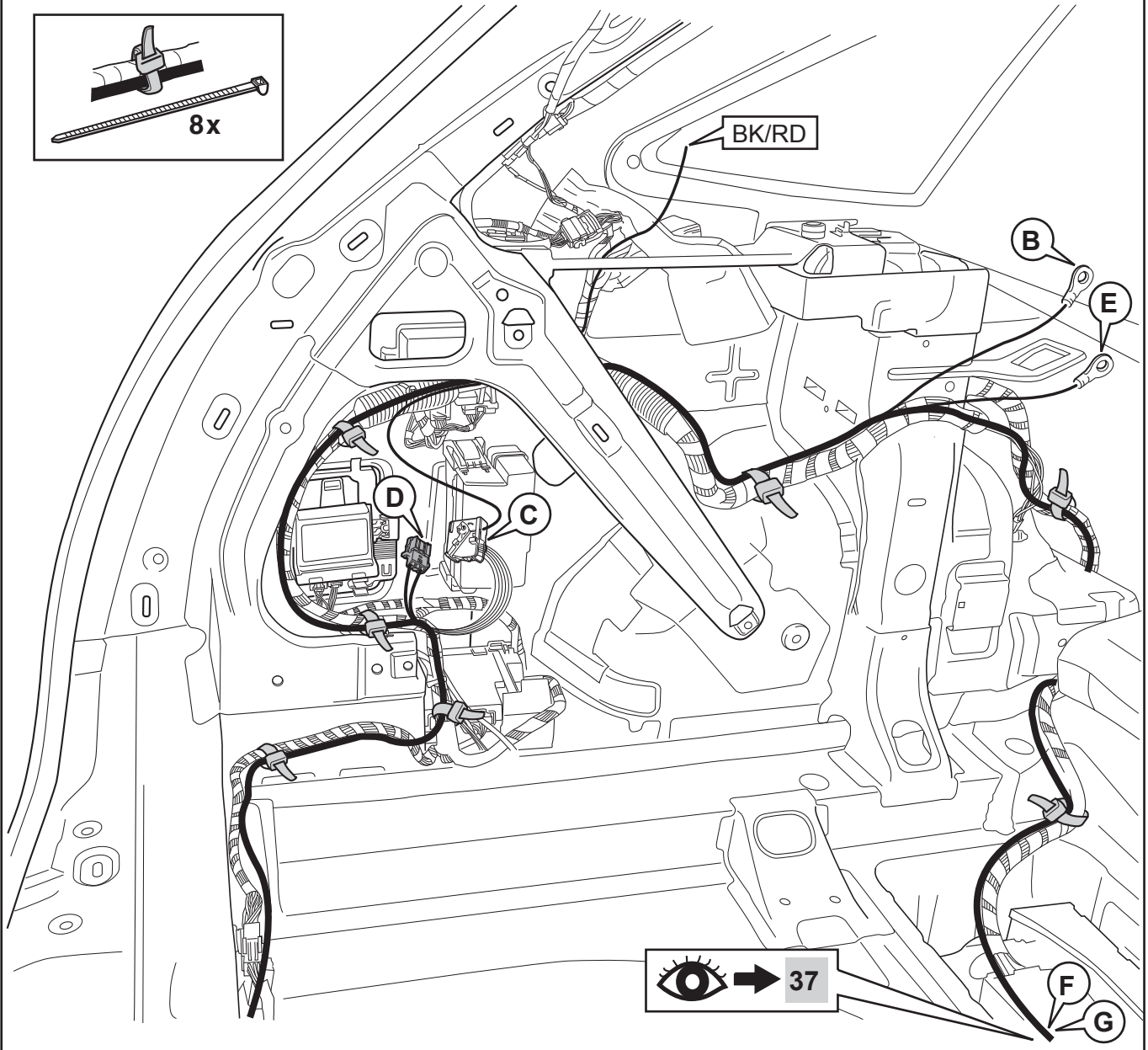
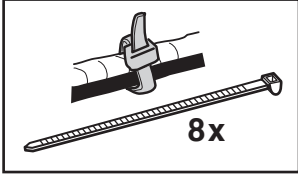

34

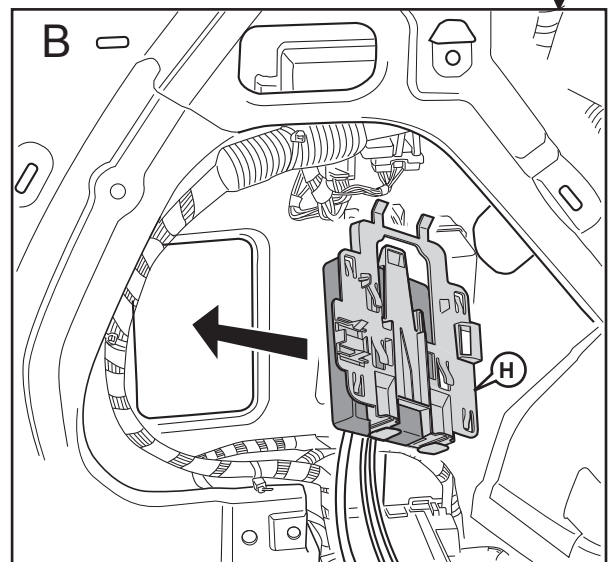
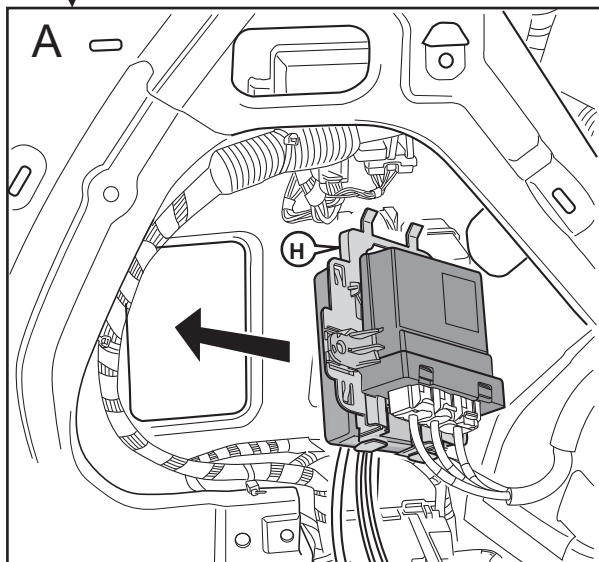
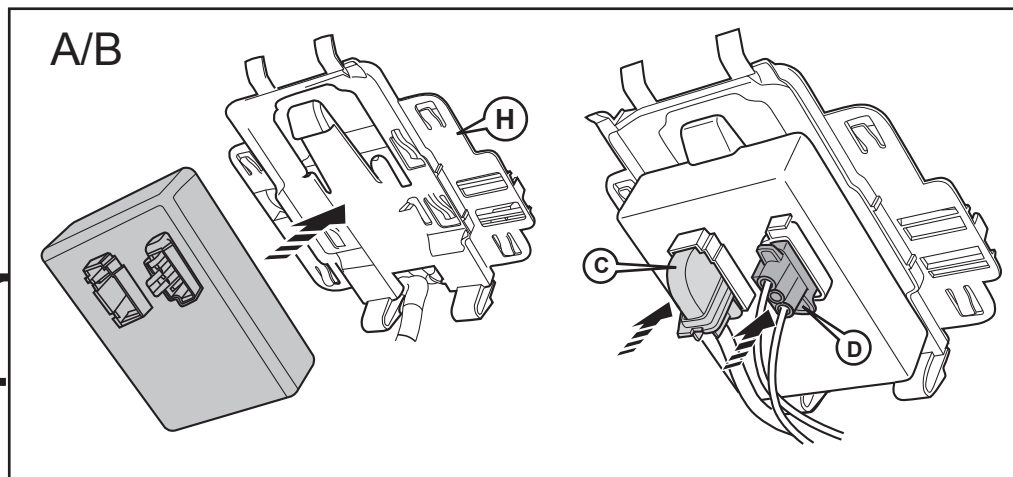
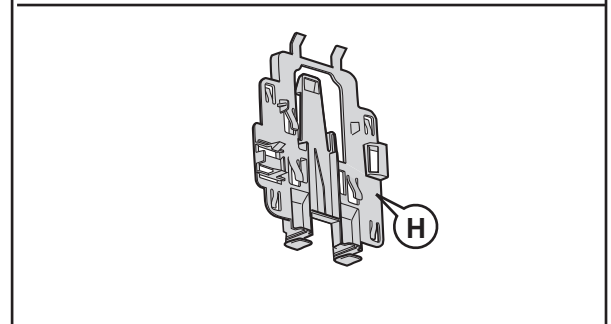
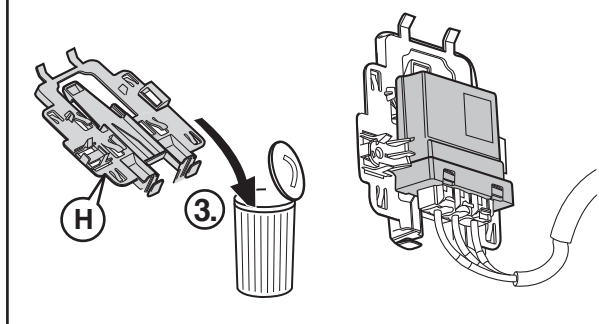
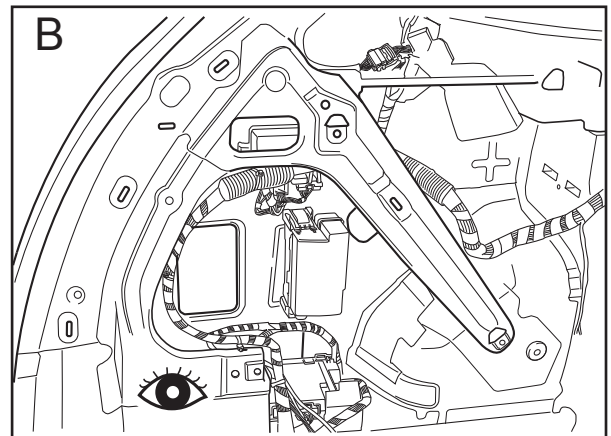
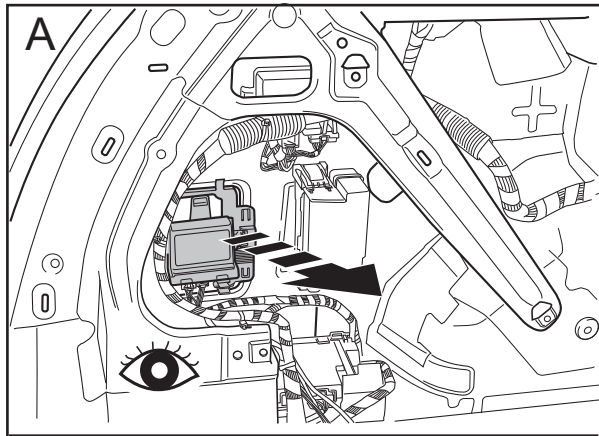



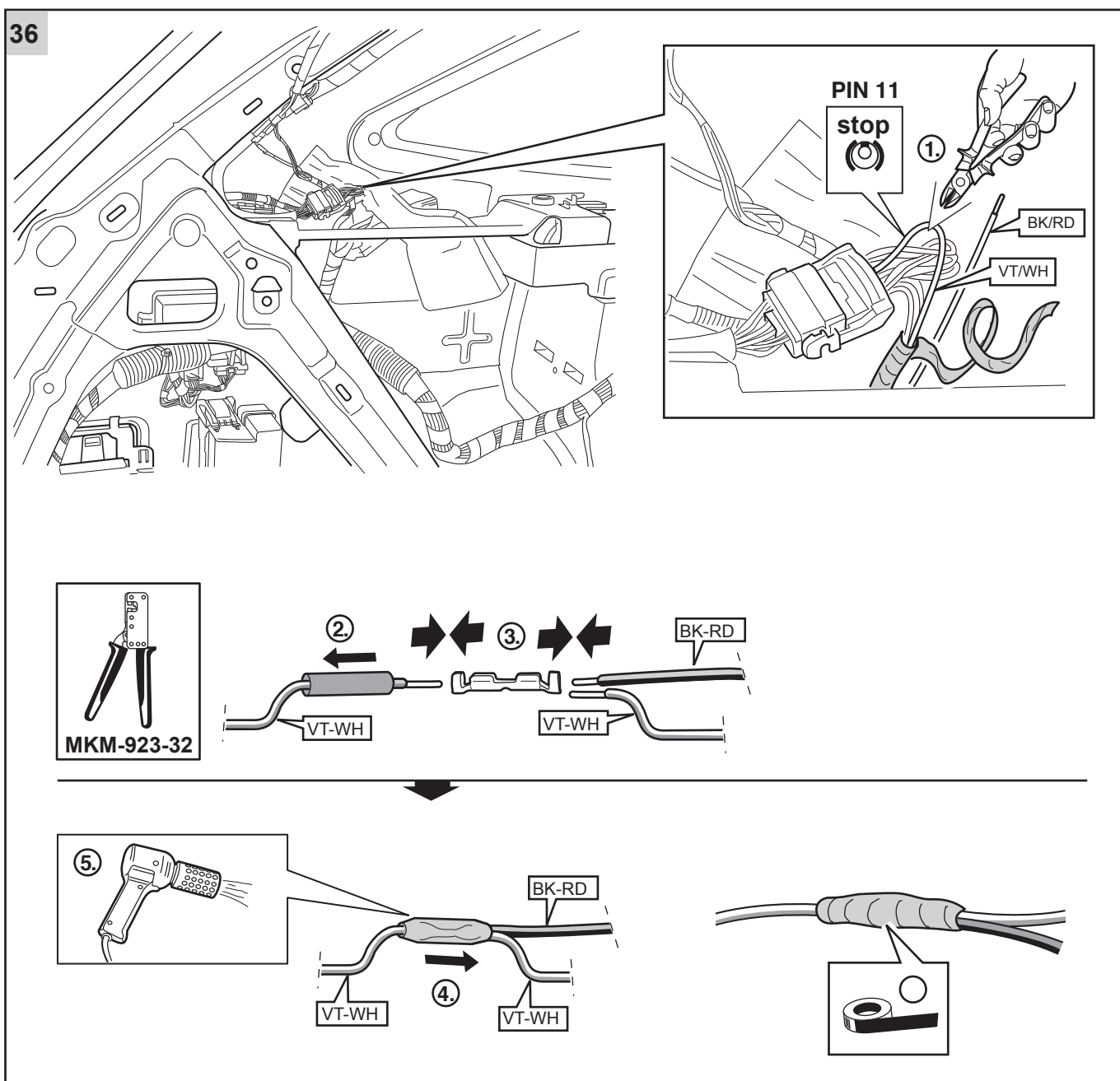
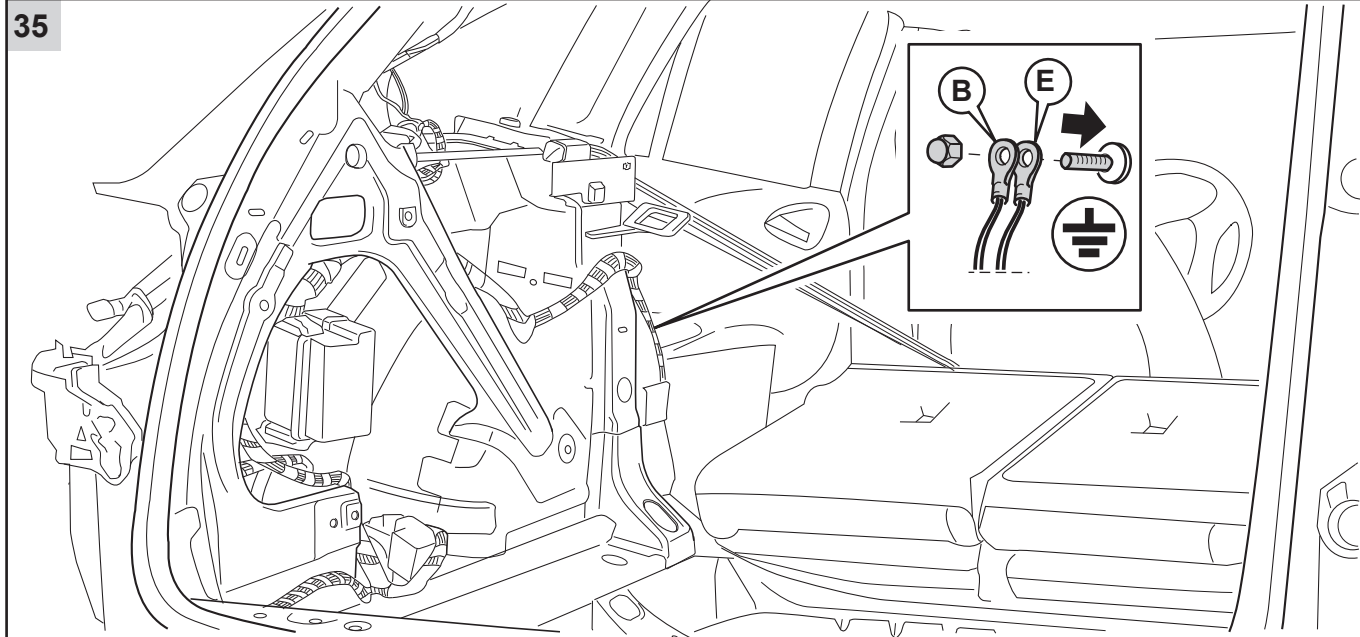

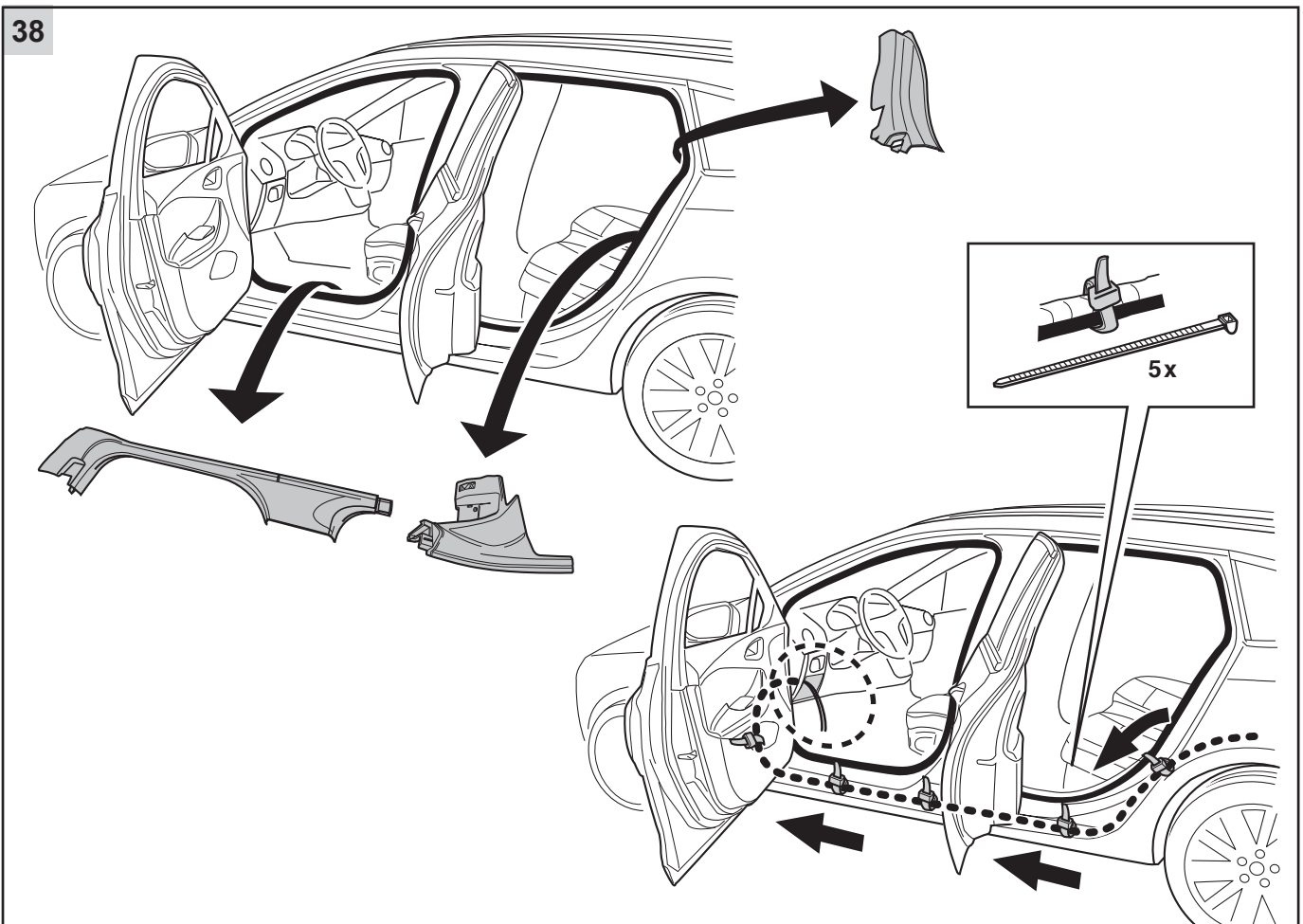
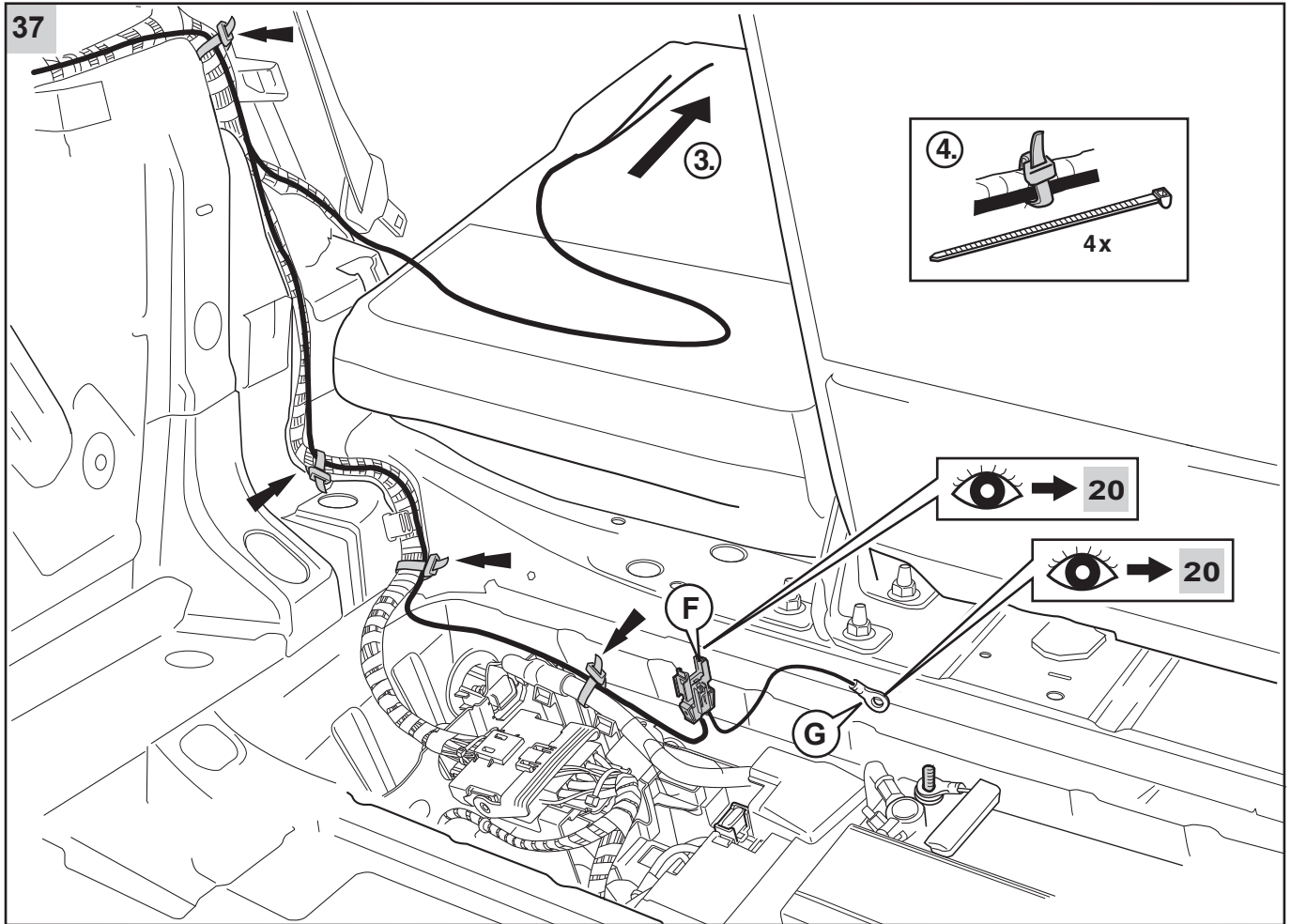

39

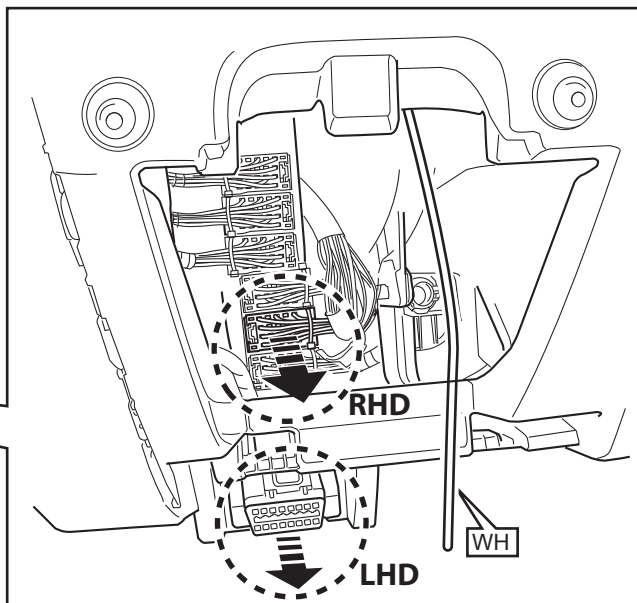
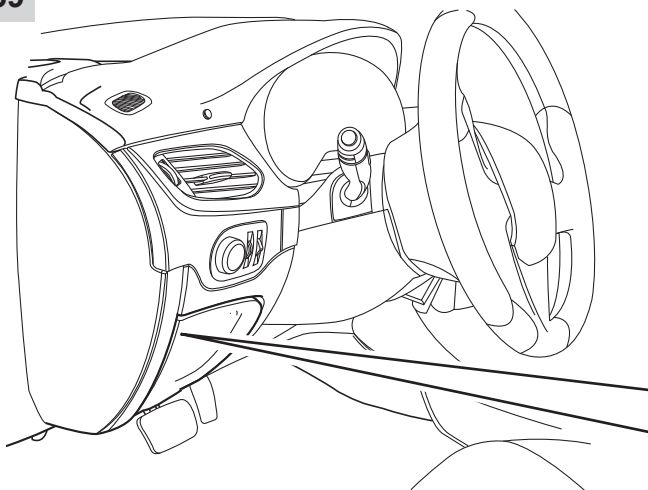

40

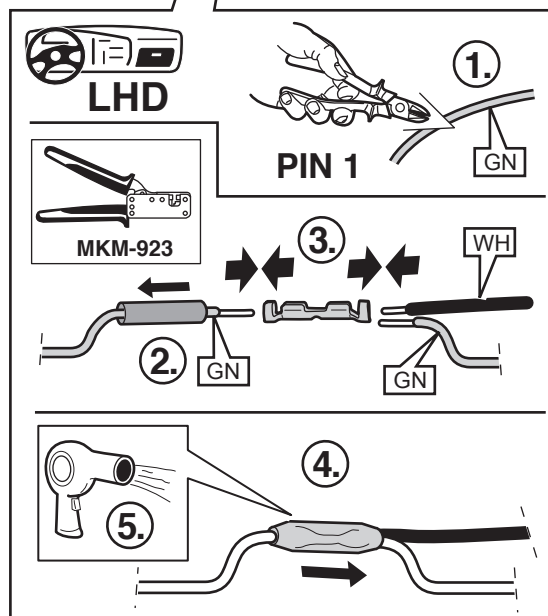
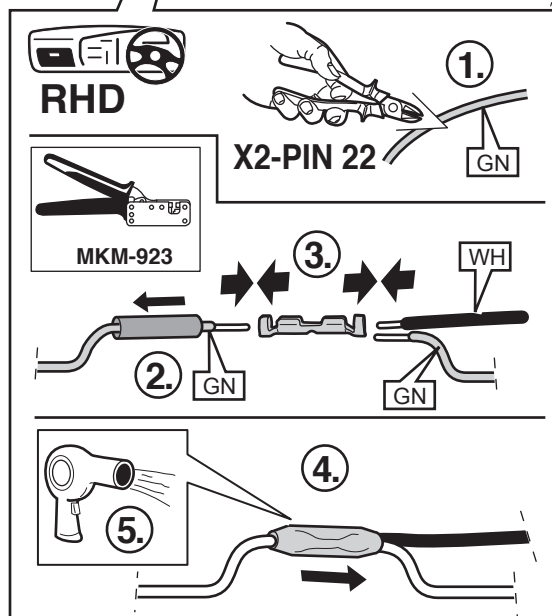
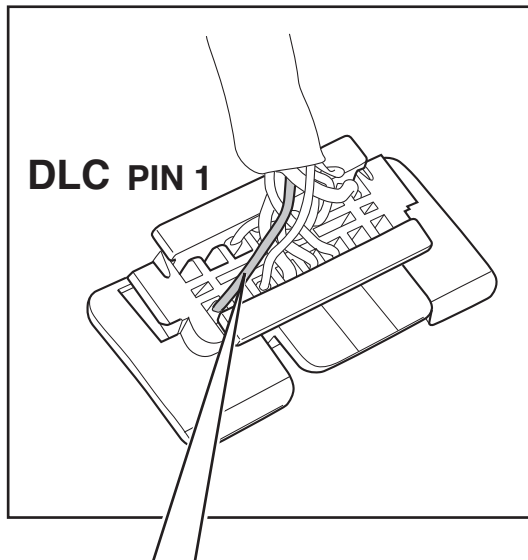
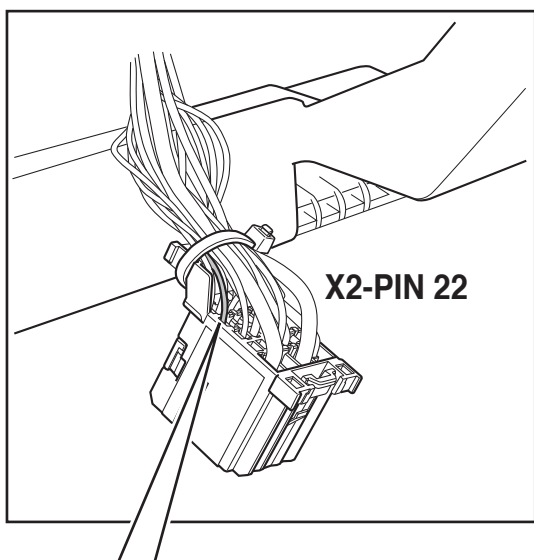

41

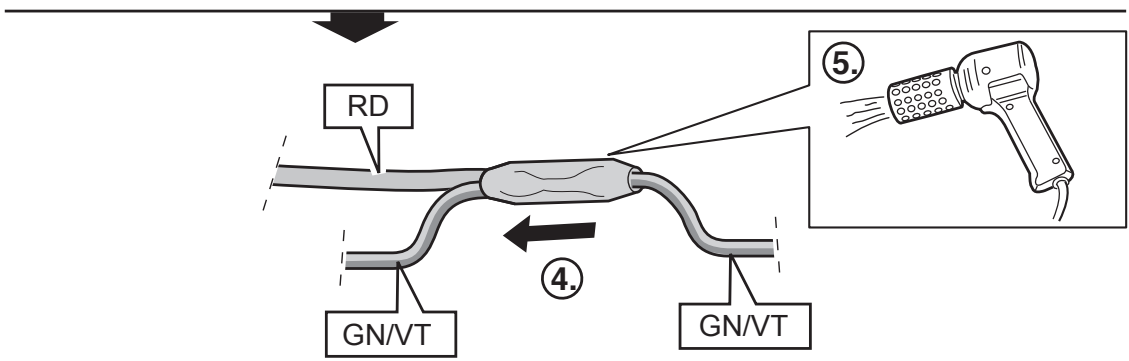
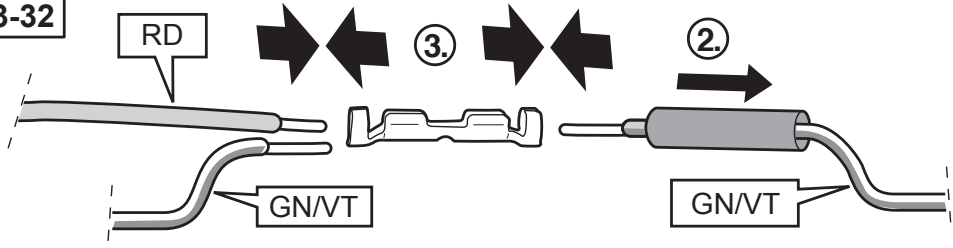
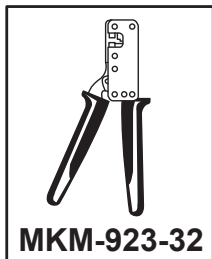
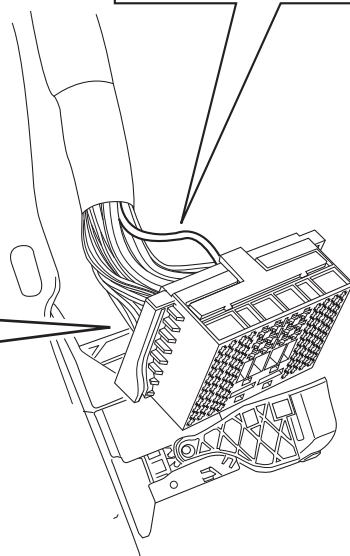
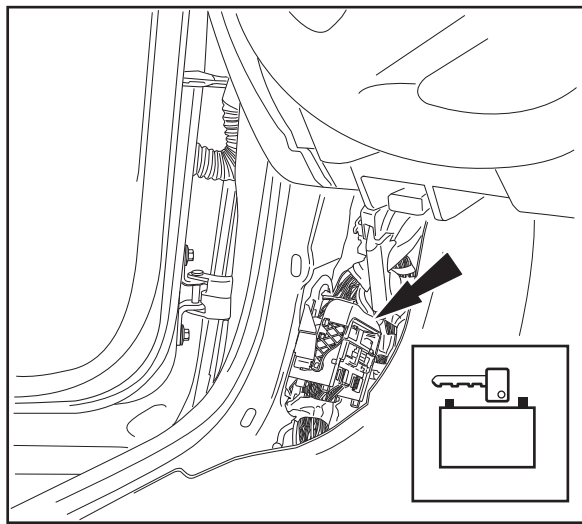
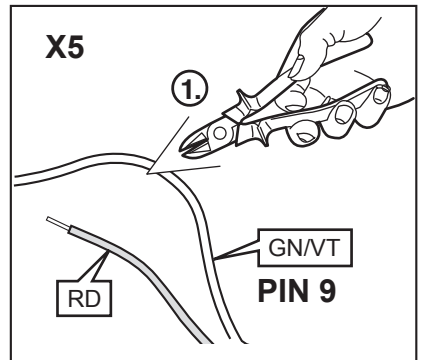
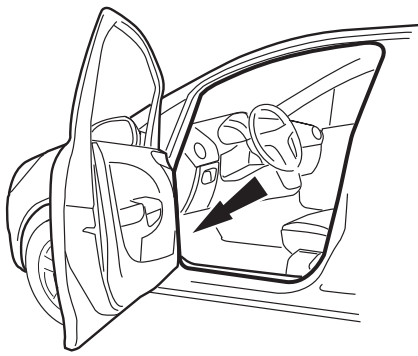

42

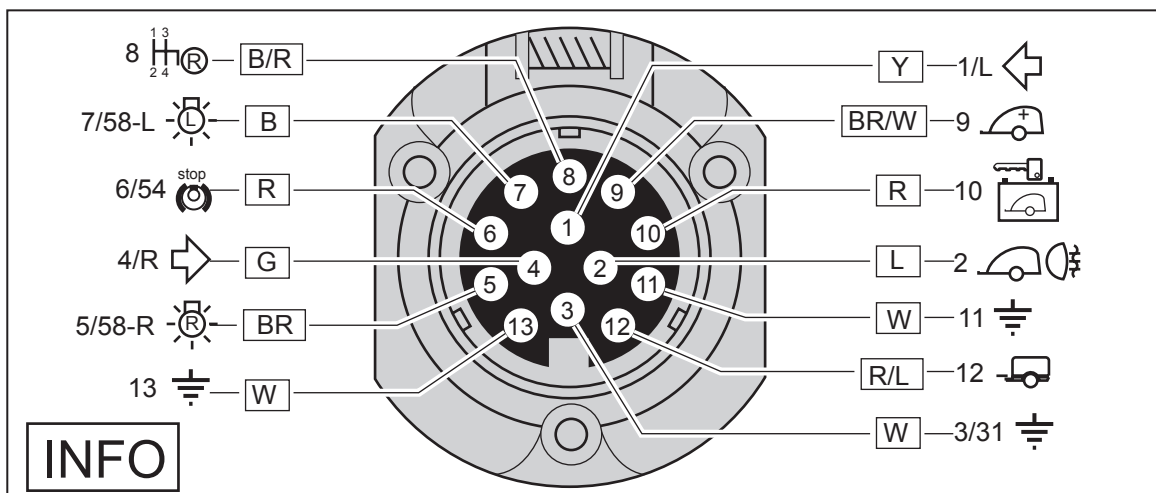
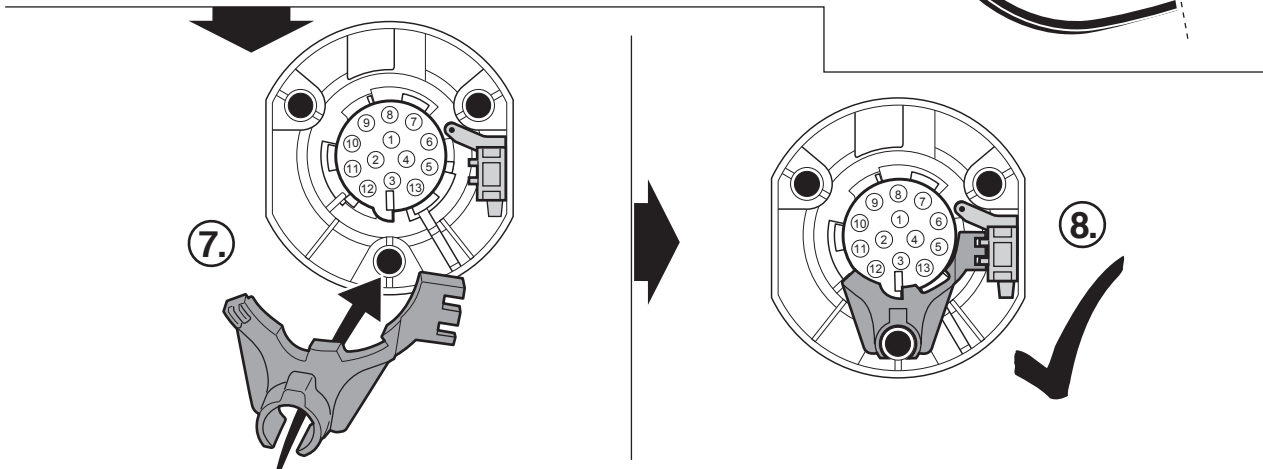
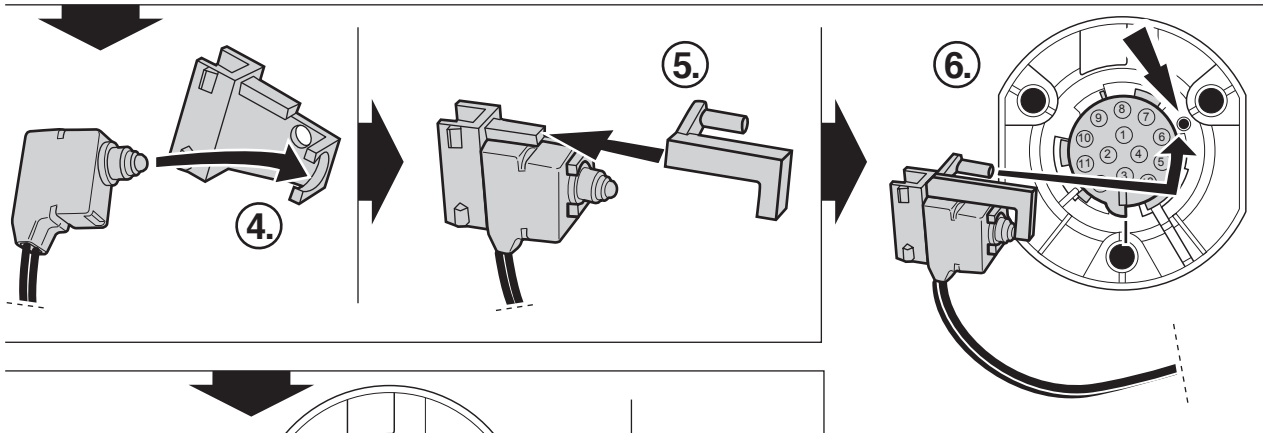
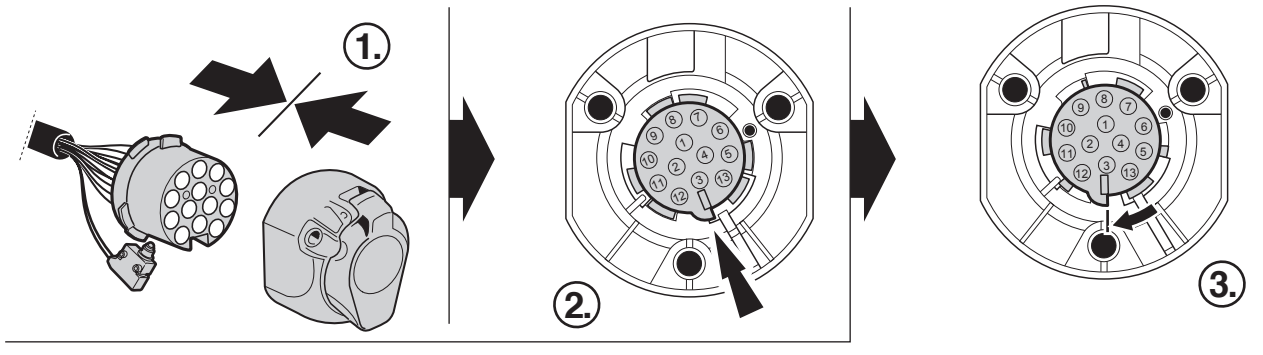
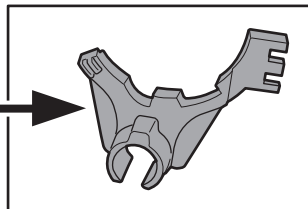

43

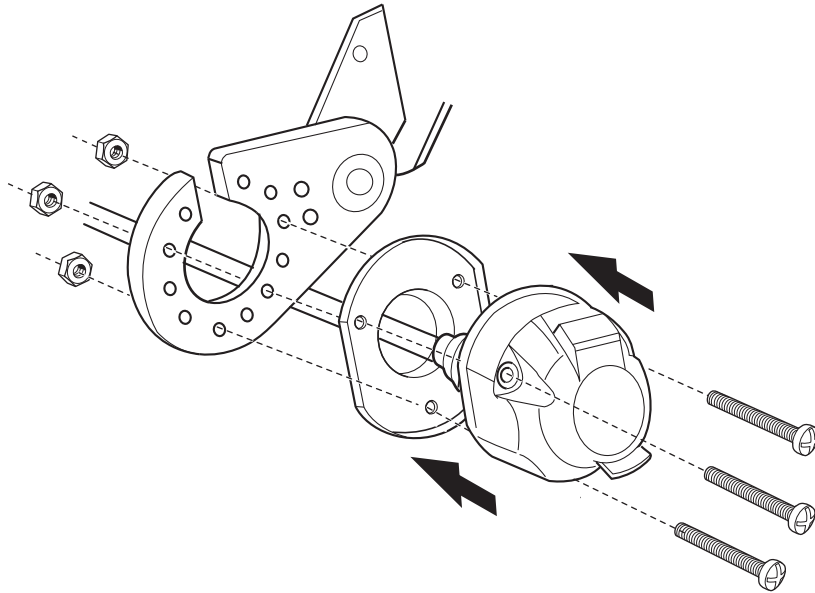

44

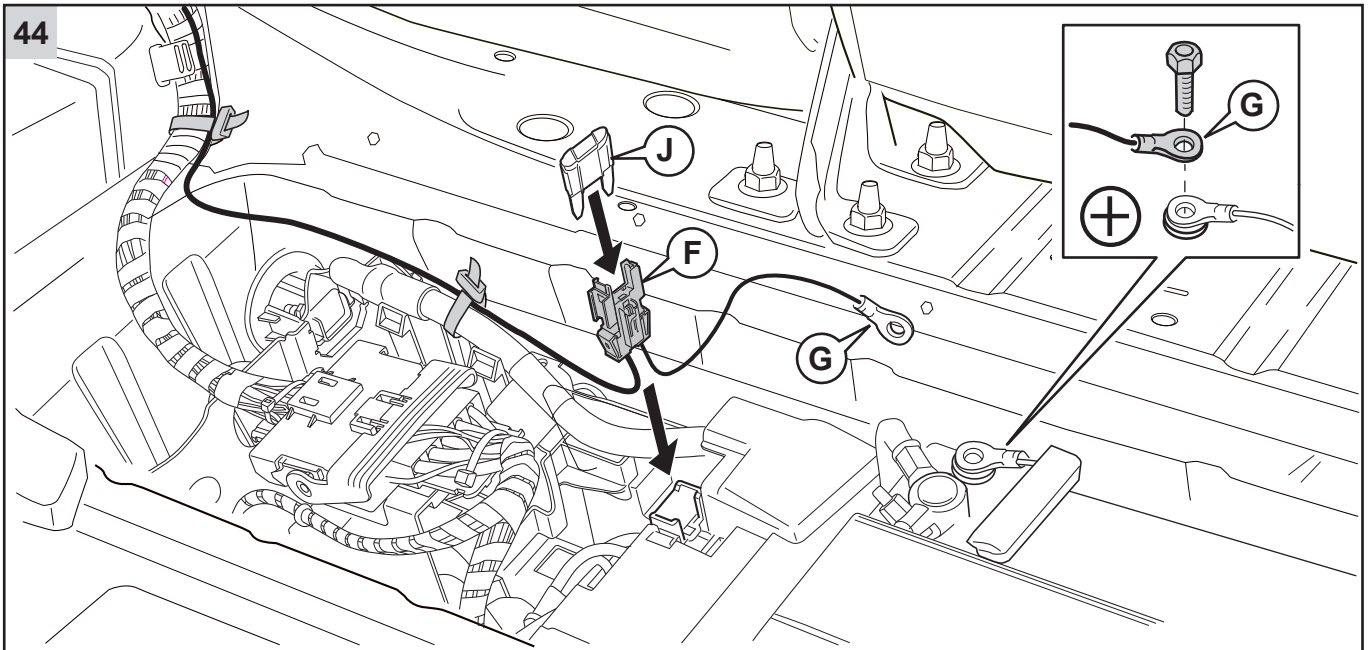

45

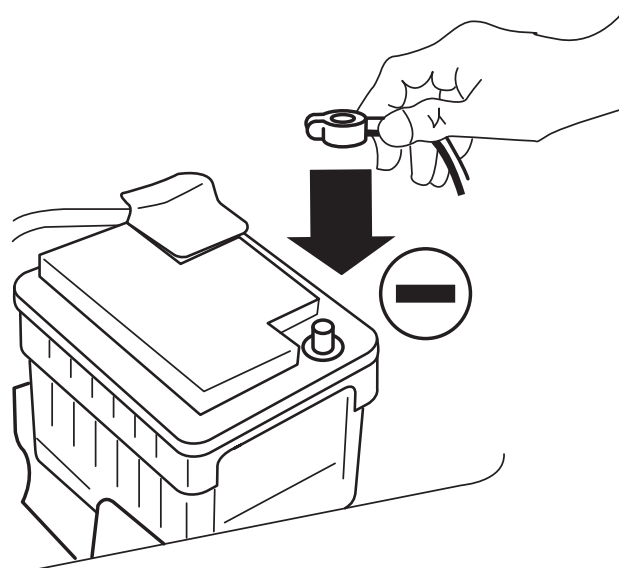

46

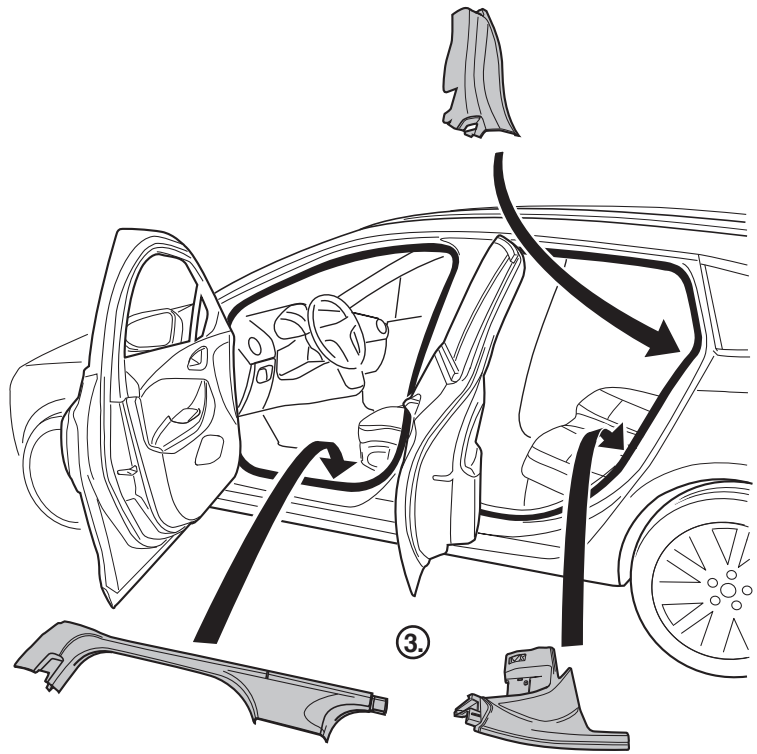
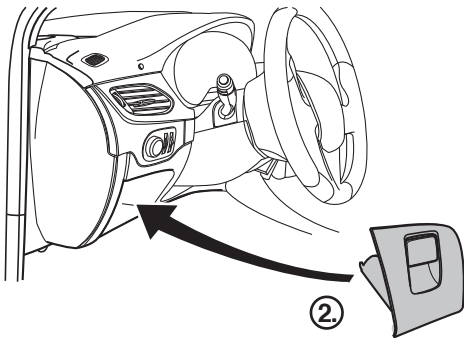

47

